

UNC School of the Arts Presents

GUYS *and* **DOLLS**

Music and Lyrics by: **FRANK LOESSER**
Book by: **JO SWERLING** and **ABE BURROWS**

Scenic Design
Garrett Daub

Costumes Design
Colleen Hall

Production Stage Manager
Andrew T. Scheer

Technical Director
John "JP" Mullican

Lighting Design
Al Crawford

Music Director
Dale Rieling

Choreographer
Edie Cowan

Director
Gus Kaikkonen

Assistant Director
Rory Gilbert

Wig and Makeup Design
Jill Haley

Sound Design
Drew Levy

Assistant Choreographer
Lindsay Carter

Guys and Dolls is a production of the University of North Carolina School of the Arts

Lindsay Bierman, Chancellor

David Nelson, Provost

Jamie Call Blankinship

Interim Dean, School of Design and Production

Wade West

Dean, School of Music

Carl Forsman

Dean, School of Drama

APRIL 9-19

Roger L. Stevens Center - Winston-Salem NC

Associate Sound Designer: **Maria Wurttele**

Assistant Sound Designer: **Graham T. Schwartz**

A1/Mix Engineer: **Tracy Cowit**

A2: **Rosio Medina**

A3: **Andrew Jerry**

Sound Crew: **Jason O'Neal**

GUYS
AND
DOLLS



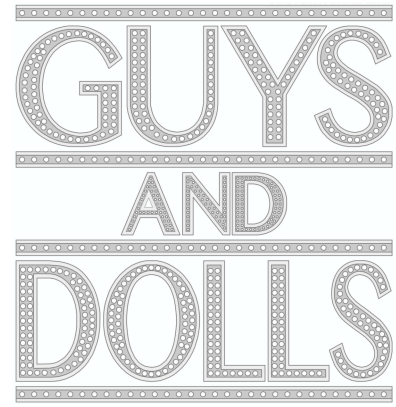
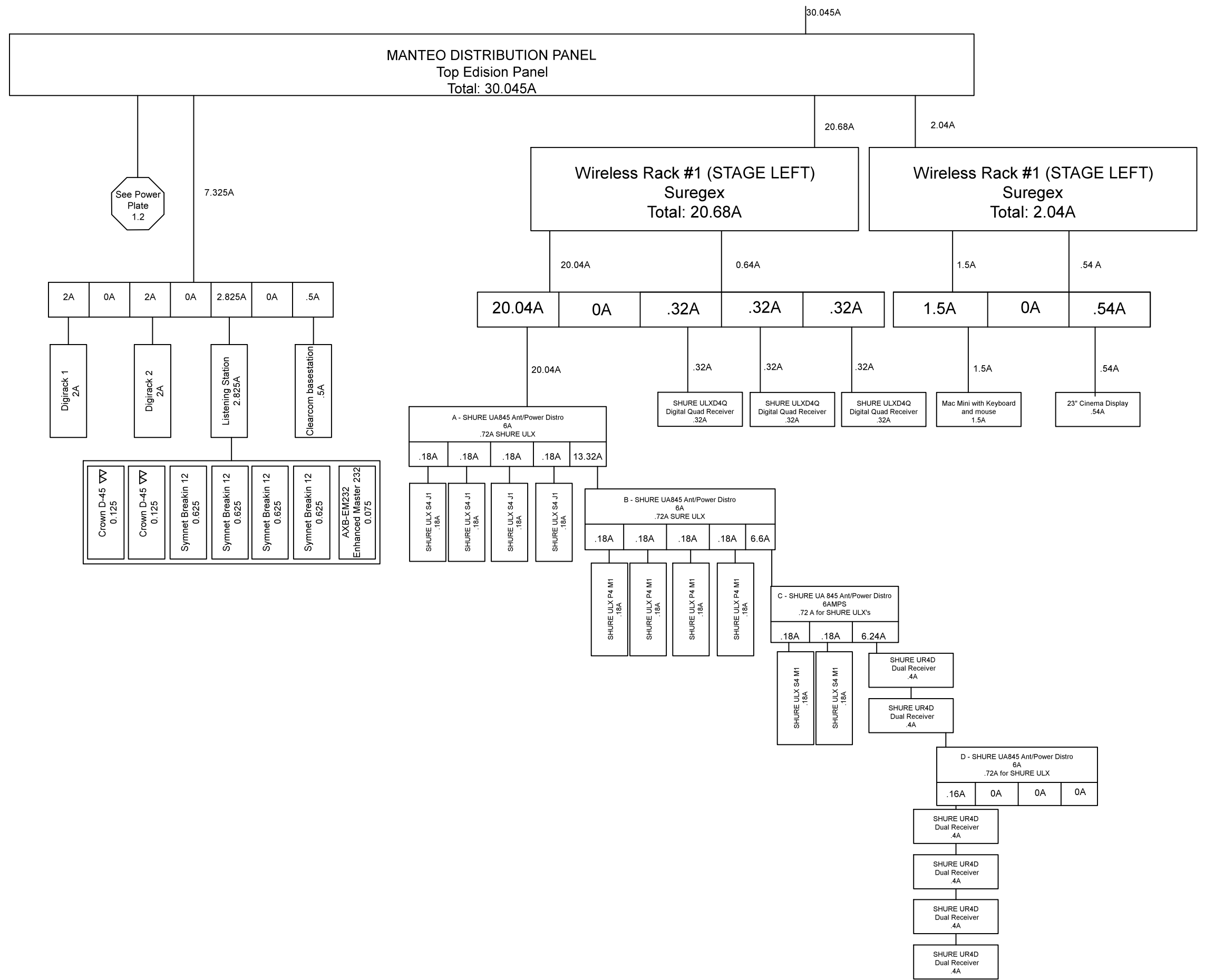

TABLE *of* CONTENTS

1.1 - POWER DIAGRAM WIRELESS	5.3 - RACK ARRANGEMENT OPTION #1	9.11 -ARRAY CALC R1 EXPORT FRONT FILLS
1.2 - POWER DIAGRAM AMPS 9-16	5.4 - RACK ARRANGEMENT OPTION #2	9.12 -ARRAY CALC R1 EXPORT SUBS
1.3 - POWER DIAGRAM AMPS 1-15	5.5 - RACK ARRANGEMENT FINAL	9.13 -ARRAY CALC RIGGING PLOT ALL ARRAY
1.4 - POWER DIAGRAM Full view of plates 1.1-1.3	6.1 - COM MATRIX	9.14 -ARRAY CALC RIGGING PLOT ALL ARRAY
1.5 - POWER DIAGRAM Full view of plates 1.6-1.10	6.2 - TECH INTERCOM LAYOUT	10.2 -D&B LOAN / BID DOCUMENT
1.6 - POWER DIAGRAM PANEL SP SL	6.3 - PERFORMANCE INTERCOM LAYOUT	10.1 -SOUND ASSOCIATES BID DOCUMENT
1.7 - POWER DIAGRAM PANEL AB BOOTH	6.4 - COM DISTRIBUTION V.5	11.1 - TIMESHEET - TRACY
1.8 - POWER DIAGRAM PANEL PB/MIX	7.1 - WIRELESS WORKBENCH FQ LIST	11.2 - TIMESHEET - TRACY
1.9 - POWER DIAGRAM FULL POWER	7.2 - WIRELESS WORKBENCH FQ LIST	11.3 - TIMESHEET - TRACY
2.1 - PATCH PLOT LOCAL I/O	7.3 - WIRELESS WORKBENCH FQ LIST	11.4 - TIMESHEET - TRACY
2.2 - PATCH PLOT DIGIRACK 1	7.4 - WIRELESS WORKBENCH FQ LIST	12.1 - TIMESHEET - GRAHAM
2.3 - PATCH PLOT DIGIRACK 2 INPUTS	7.5 - RF LABELS	12.2 - TIMESHEET - GRAHAM
2.4 - PATCH PLOT DIGIRACK 2 INPUTS	8.1 - FRONT FILL RIGGING D&B E8	12.3 - TIMESHEET - GRAHAM
2.5 - PATCH PLOT DIGIRACK 2 OUTPUTS	8.2 - Y8 SOUND TRUSS ARRAY RIGGING	12.4 - TIMESHEET - GRAHAM
2.6 - PATCH PLOT DIGIRACK 2 OUTPUTS	8.3 - ORGAN BAY HL, HR RIGGING	13.1 - TIMESHEET - ROSIO
3.1 - ONE LINE DIGIRACK 1 I/O	8.4 - OH FOLDBACK RIGGING, PLACEMENT	13.2 - TIMESHEET - ROSIO
3.2 - ONE LINE DIGIRACK 1 I/O	8.5 - UNDERBALC RIGGING D&B E8	13.3 - TIMESHEET - ROSIO
3.3 - ONE LINE SD10T LOCAL I/O	8.6 - GALLERY RIGGING D&B C7 TOP	13.4 - TIMESHEET - ROSIO
3.4 - ONE LINE DIGIRACK 2 - WIRELESS I/O	8.7 - BALC FILLS X7 D&B E5 W/ BALL JOINT ADAPTER	14.1 - TIMESHEET - ANDREW JERRY
3.5 - ONE LINE DIGIRACK 2 - WIRELESS I/O	9.1 - ARRAY CALC 3D PLOT	14.2 - TIMESHEET - ANDREW JERRY
3.6 - ONE LINE DIGIRACK 2 - WIRELESS I/O	9.2 - ARRAY CALC SYSTEM ALIGNMENT	14.3 - TIMESHEET - ANDREW JERRY
3.7 - ONE LINE DIGIRACK 2 I/O SIDECAR	9.3 - ARRAY CALC Y8 ARRAY RIGGING	14.4 - TIMESHEET - ANDREW JERRY
3.8 - ONE LINE DIGIRACK 2 OUTPUTS	9.4 - ARRAY CALC Q SERIES ARRAY RIGGING	15.1 - TIMESHEET - JASON O'NEAL
3.9 - ONE LINE DIGIRACK 2 OUTPUTS	9.5 - ARRAY CALC PARTS LIST	15.2 - TIMESHEET - JASON O'NEAL
3.10-ONE LINE DIGIRACK 2 OUTPUTS	9.6 - ARRAY CALC R1 EXPORT - MAIN Y8 ARRAY	15.3 - TIMESHEET - JASON O'NEAL
3.11-ONE LINE FULL LAYOUT	9.7 - ARRAY CALC R1 EXPORT DELAY Q ARRAY	15.4 - TIMESHEET - JASON O'NEAL
4.1 - ORCH PIT LAYOUT	9.8 - ARRAY CALC R1 EXPORT DELAY ARRAY Y8	
5.1 - RACK DIAGRAM	9.9 - ARRAY CALC R1 EXPORT UNDERBALCS	
5.2 - RACK DIAGRAM HOUSE RACKS	9.10 -ARRAY CALC R1 EXPORT BALC FILLS	



Tracy Cowit
Head Sound A1

Sound Designer
Drew Levy

Associate Sound Designer
Maria Wurttele
305.878.0893
wurttele.mf@artist.uncsa.edu

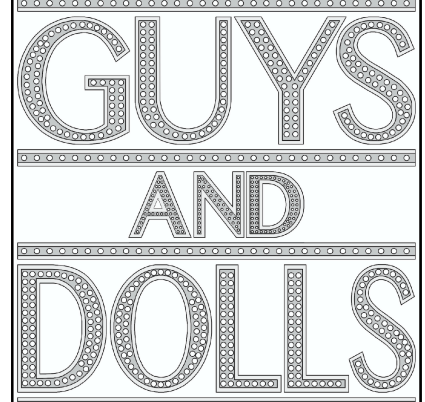

Venue
STEVENS CENTER

Producer
UNCSA

Director
GUS KAIKKONEN

Production Manager
DENNIS BOOTH

Scenic Designer
GARRET DAUB

Lighting Designer
AL CRAWFORD

Drawn By: TAC
File Name: Guys and Dolls v2015.dwg
Drawing Date: 04/25/15

Load-In Date: 20 MARCH, 2015
Load-Out Date: 19 APRIL, 2015

Power Diagram
WIRELESS

Plate
1.1

Tracy Cowit

Head Sound A1

Sound Designer

Drew Levy

Associate Sound Designer

Maria Wurttele

305.878.0893

wurttele.mf@artist.uncsa.edu

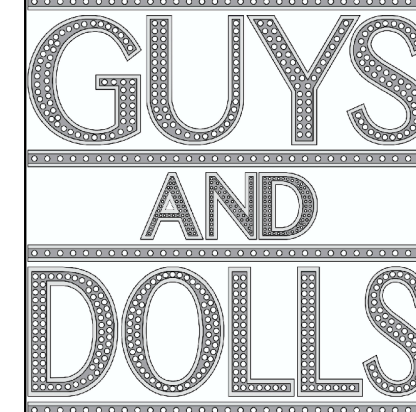

Venue

STEVENS CENTER

Producer

UNCSA

Director

GUS KAIKKONEN

Production Manager

DENNIS BOOTH

Scenic Designer

GARRET DAUB

Lighting Designer

AL CRAWFORD

Drawn By: TAC

File Name: Guys and Dolls v2015.dwg

Drawing Date: 04/25/15

Load-In Date

20 MARCH, 2015

Load-Out Date

19 APRIL, 2015

Power Diagram

AMPS 9-16

Plate
1.2

See Power
Plate
1.3

MANTEO DISTRIBUTION PANEL
Middle Panel
3-30A Breakout

135A

135A

RACK PACK
Amp Rack SL
4 -30 AMPS Breakouts
Total: 135A

30 A

30 A

30 A

45A

#1 30A

2 30A

#3 30A

#4 30A

15A

0A

15A

0A

15A

0A

15A

0A

15A

0A

15A

0A

15A

0A

15A

0A

15A

d&b D12 #9
15A

d&b D12 #10
15A

d&b D12 #11
15A

d&b D12 #12
15A

d&b D12 #13
15A

d&b D12 #14
15A

d&b D12 #15
15A

d&b D12 #16
15A

d&b D12 #16
15A

See Power Plate 1.4

120A
MANTEO DISTRIBUTION PANEL
 Bottom Distribution Panel
 3-30A Breakout
 120A

RACK PACK
 Amp Rack SL
 2-30 2-20 AMPS Breakouts
 Total: 120A

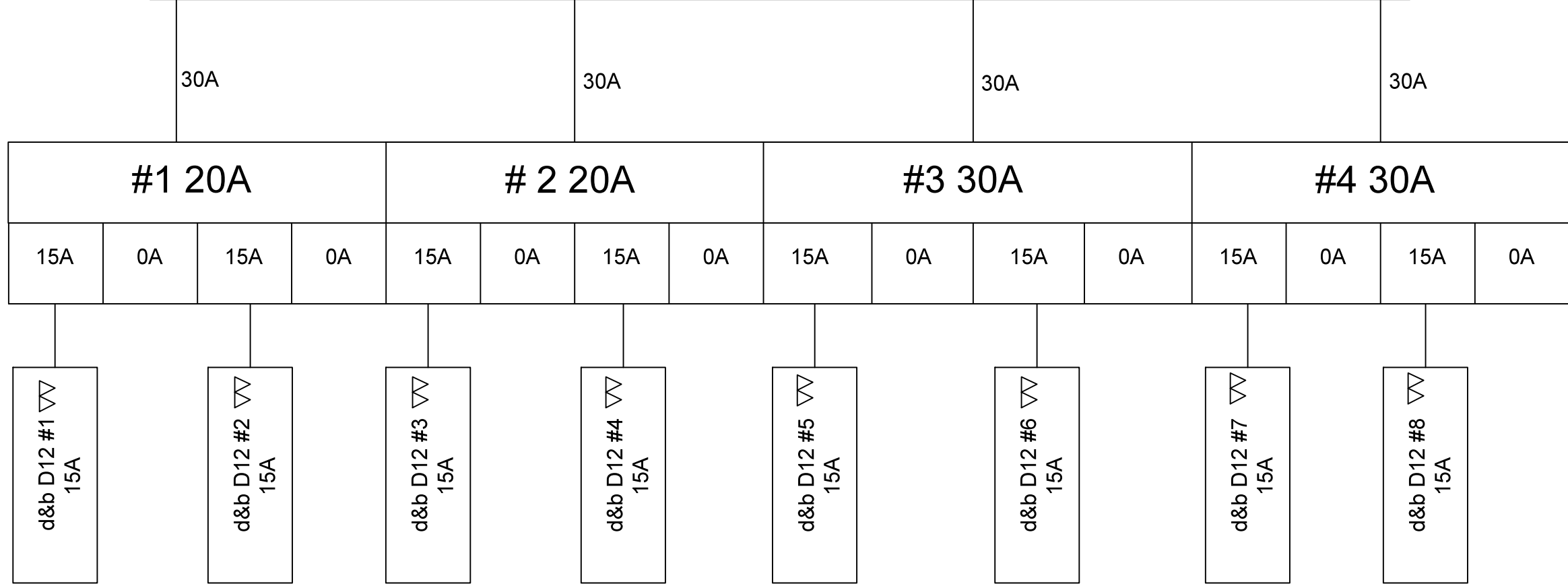

Tracy Cowit
 Head Sound A1

Sound Designer
 Drew Levy

Associate Sound Designer
 Maria Wurttelle
 305.878.0893
 wurttelle.mf@artist.uncsa.edu

**GUYS
 AND
 DOLLS**

Venue
 STEVENS CENTER

Producer
 UNCSA

Director
 GUS KAIKKONEN

Production Manager
 DENNIS BOOTH

Scenic Designer
 GARRET DAUB

Lighting Designer
 AL CRAWFORD

Drawn By: TAC
 File Name: Guys and Dolls v2015.dwg
 Drawing Date: 04/25/15

Load-In Date: 20 MARCH, 2015
 Load-Out Date: 19 APRIL, 2015

Power Diagram
 AMPS 1-15

Plate
1.3

Tracy Cowit

Head Sound A1

Sound Designer
Drew Levy

Associate Sound Designer
Maria Wurttele
305.878.0893
wurttele.mf@artist.unca.edu

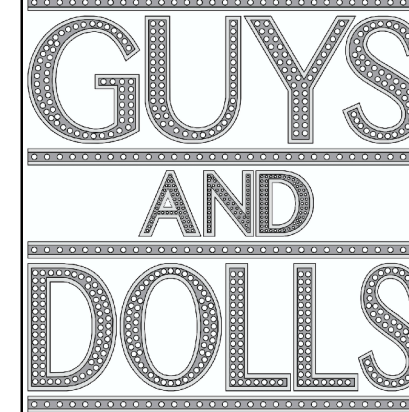

Venue
STEVENS CENTER

Producer
UNCSA

Director
GUS KAIKKONEN

Production Manager
DENNIS BOOTH

Scenic Designer
GARRET DAUB

Lighting Designer
AL CRAWFORD

Drawn By: TAC
File Name: Guys and Dolls v2015.dwg
Drawing Date: 04/25/15

Load-In Date: 20 MARCH, 2015
Load-Out Date: 19 APRIL, 2015

Power Diagram
Full View of plates 1.1-1.3

Plate
1.4

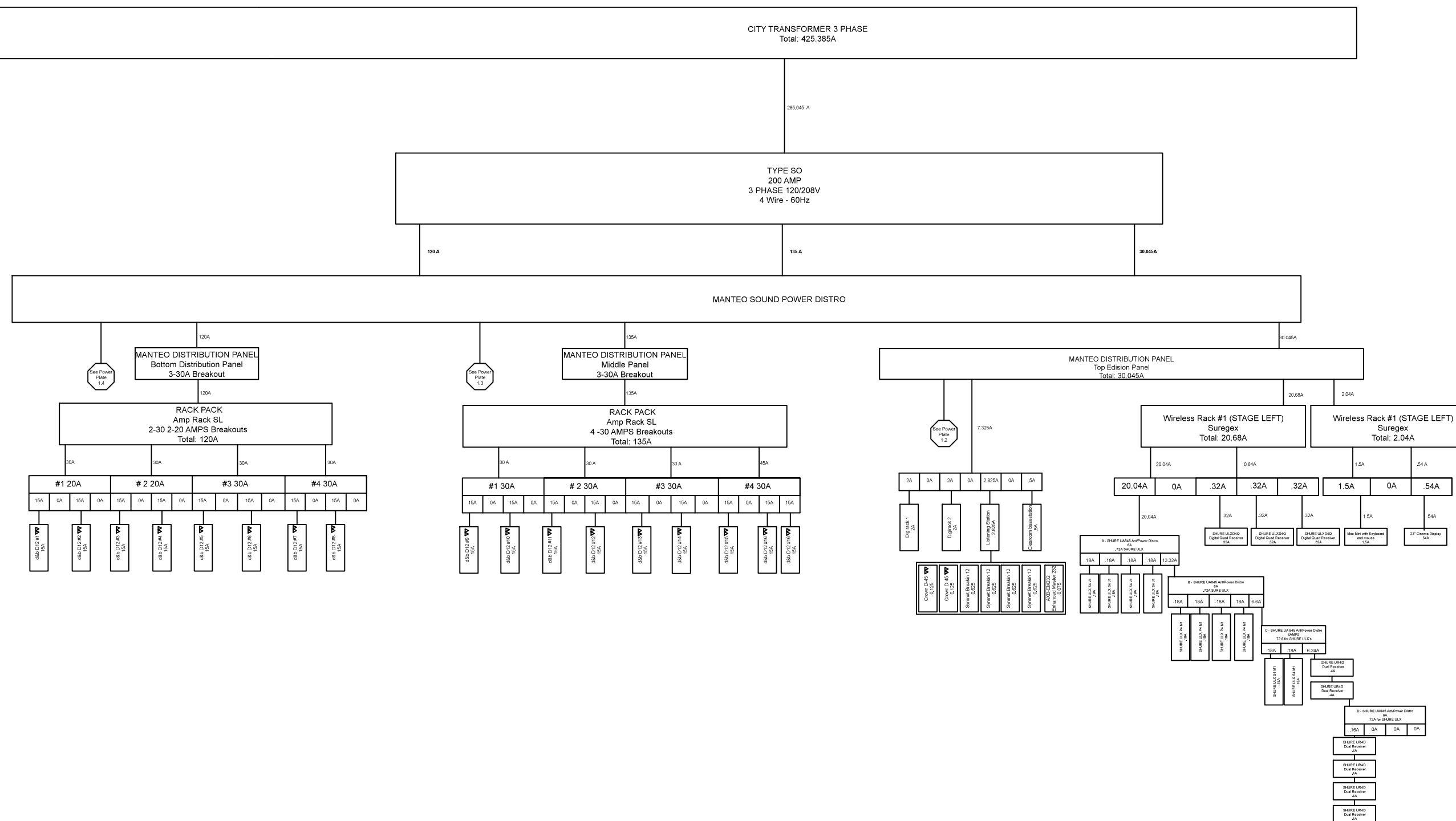

Tracy Cowit

Head Sound A1

Sound Designer
Drew Levy

Associate Sound Designer
Maria Wurttele
305.878.0893
wurttele.mf@artist.unca.edu

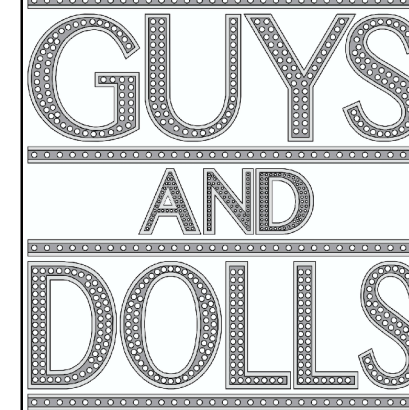

Venue
STEVENS CENTER

Producer
UNCSA

Director
GUS KAIKKONEN

Production Manager
DENNIS BOOTH

Scenic Designer
GARRET DAUB

Lighting Designer
AL CRAWFORD

Drawn By: TAC
File Name: Guys and Dolls v2015.dwg
Drawing Date: 04/25/15

Load-In Date: 20 MARCH, 2015
Load-Out Date: 19 APRIL, 2015

Power Diagram
Full view of plates 1.6-1.10

Plate
1.5

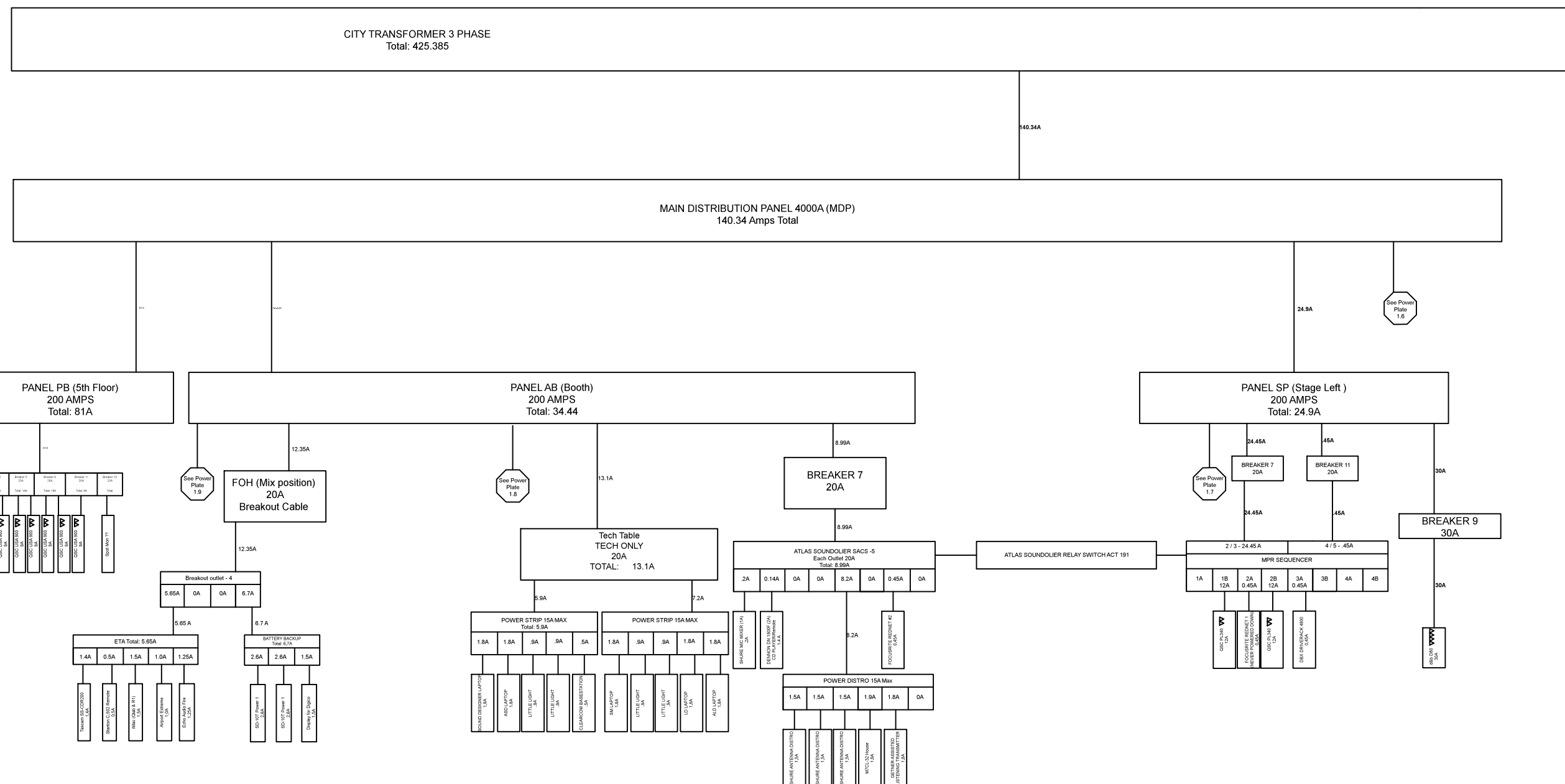

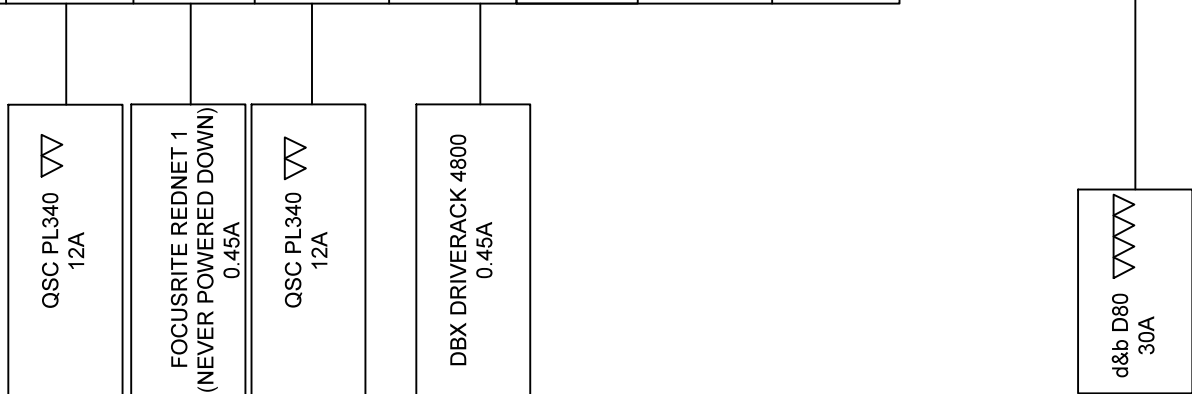
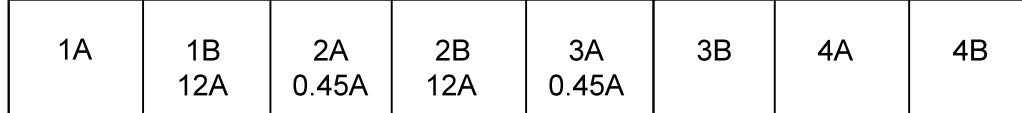
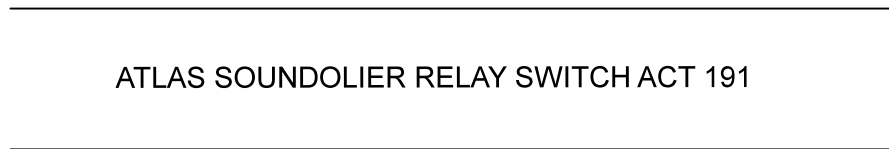
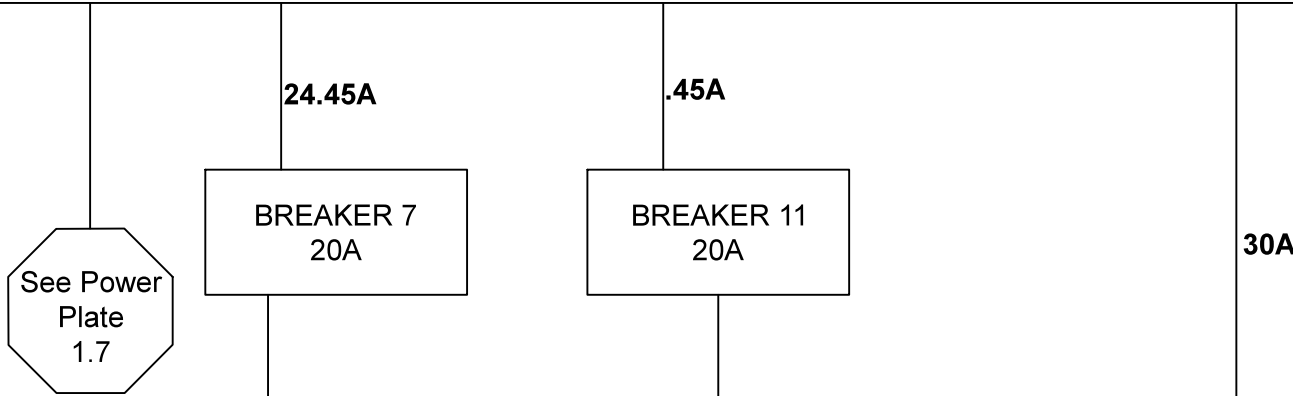
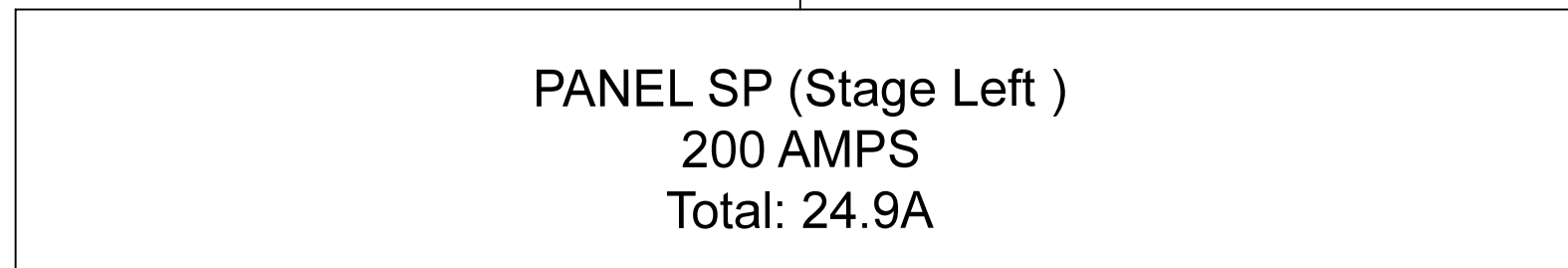

Tracy Cowit

Head Sound A1

Sound Designer
Drew Levy

Associate Sound Designer
Maria Wurttele
305.878.0893
wurttele.mf@artist.uncsa.edu

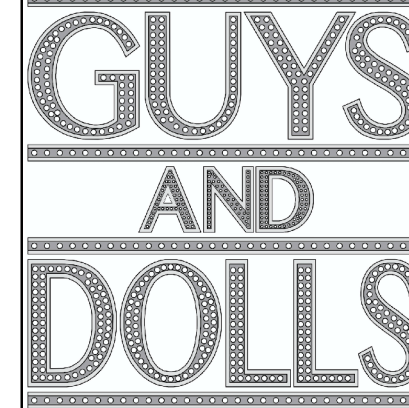

Venue
STEVENS CENTER

Producer
UNCSA

Director
GUS KAIKKONEN

Production Manager
DENNIS BOOTH

Scenic Designer
GARRET DAUB

Lighting Designer
AL CRAWFORD

Drawn By: TAC
File Name: Guys and Dolls v2015.dwg
Drawing Date: 04/25/15

Load-In Date 20 MARCH, 2015	Load-Out Date 19 APRIL, 2015
--------------------------------	---------------------------------

Power Diagram
Panel SP SL

Plate
1.6

Tracy Cowit

Head Sound A1

Sound Designer
Drew Levy

Associate Sound Designer
Maria Wurttele

305.878.0893

wurttele.mf@artist.uncsa.edu

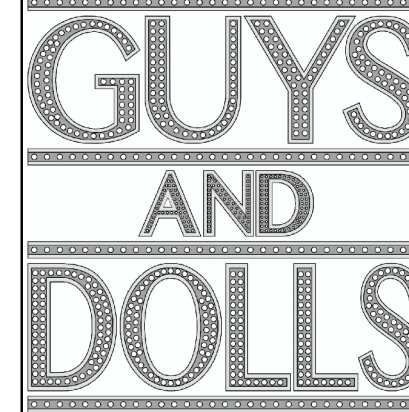

Venue

STEVENS CENTER

Producer

UNCSA

Director

GUS KAIKKONEN

Production Manager

DENNIS BOOTH

Scenic Designer

GARRET DAUB

Lighting Designer

AL CRAWFORD

Drawn By: TAC

File Name: Guys and Dolls v2015.dwg

Drawing Date: 04/25/15

Load-In Date

20 MARCH, 2015

Load-Out Date

19 APRIL, 2015

Power Diagram
Panel AB Booth

Plate
1.7

PANEL AB (Booth)
200 AMPS
Total: 34.44

See Power Plate
1.8

13.1A

Tech Table
TECH ONLY
20A
TOTAL: 13.1A

5.9A

7.2A

POWER STRIP 15A MAX
Total: 5.9A

POWER STRIP 15A MAX

1.8A 1.8A .9A .9A .5A

1.8A .9A .9A 1.8A 1.8A

SOUND DESIGNER LAPTOP 1.8A
ASD LAPTOP 1.8A
LITTLE LIGHT .9A
LITTLE LIGHT .9A
CLEARCOM BASESTATION .5A

SM LAPTOP 1.8A
LITTLE LIGHT .9A
LITTLE LIGHT .9A
LD LAPTOP 1.8A
ALD LAPTOP 1.8A

8.99A

BREAKER 7
20A

8.99A

ATLAS SOUNDOLIER SACS -5
Each Outlet 20A
Total: 8.99A

ATLAS SOUNDOLIER RELAY SWITCH ACT 191

.2A 0.14A 0A 0A 8.2A 0A 0.45A 0A

SHURE MIC MIXER (1A)
.2A

DENNON DN 1800F (2A)
CD PLAYER/Remote
1.4A

8.2A

FOCUSRITE REDNET #2
0.45A

POWER DISTRO 15A Max

1.5A 1.5A 1.5A 1.9A 1.8A 0A

SHURE ANTENNA DISTRO 1.5A
SHURE ANTENNA DISTRO 1.5A
SHURE ANTENNA DISTRO 1.5A
M7CL-32 House 1.9A
GETNER ASSISTED LISTENING TRANSMITTER 1.8A

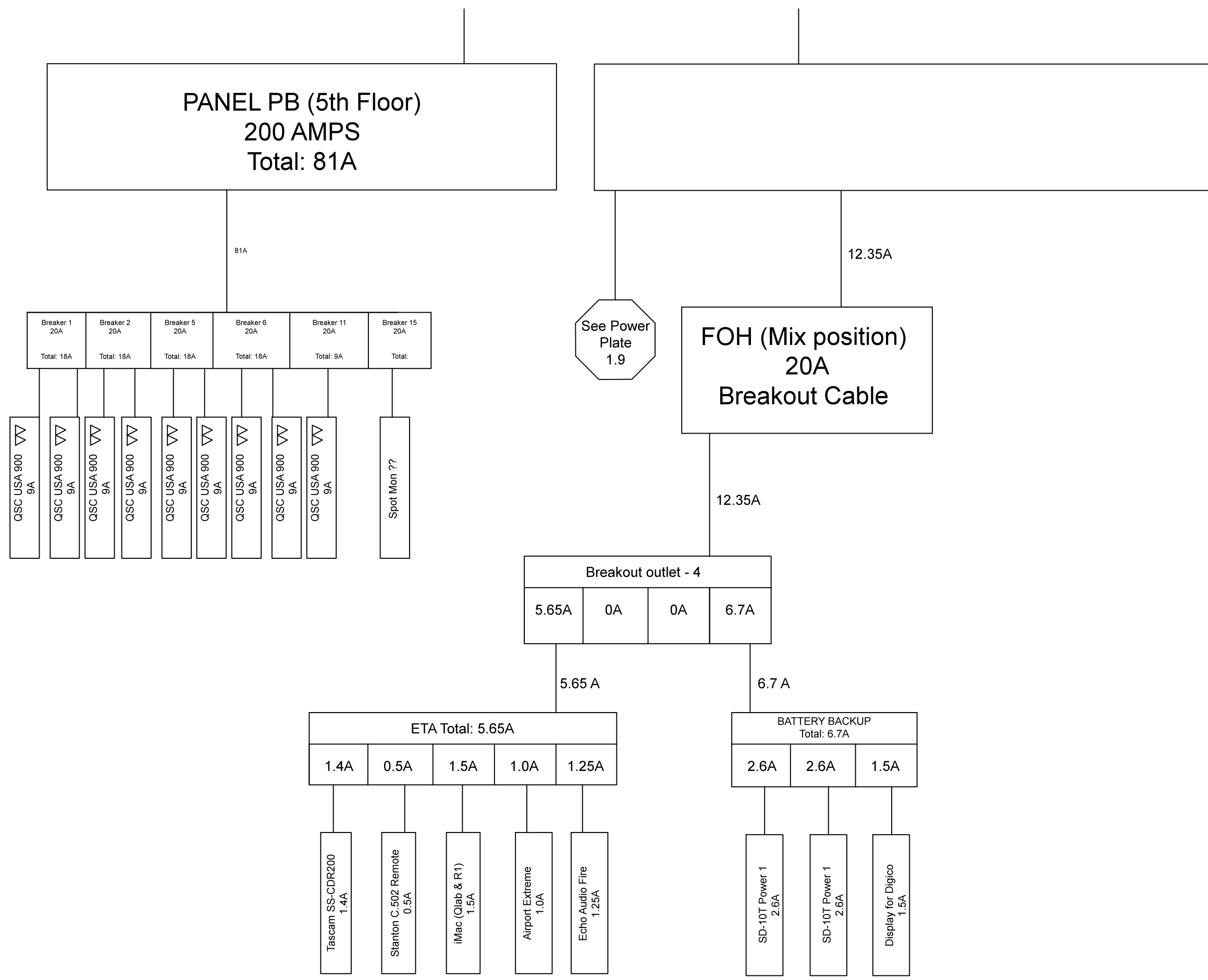

Tracy Cowit
Head Sound A1

Sound Designer
Drew Levy

Associate Sound Designer
Maria Wurttele

305.878.0893
wurttele.mf@artist.uncsa.edu

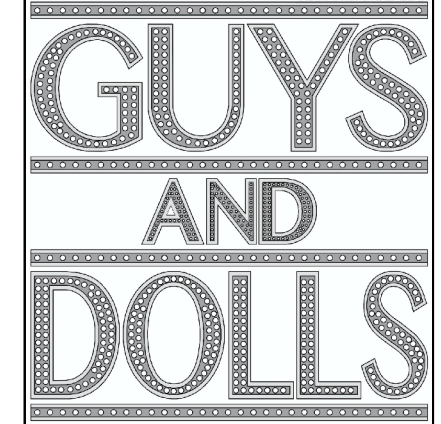

Venue
STEVENS CENTER

Producer
UNCSA

Director
GUS KAIKKONEN

Production Manager
DENNIS BOOTH

Scenic Designer
GARRET DAUB

Lighting Designer
AL CRAWFORD

Drawn By: TAC
File Name: Guys and Dolls v2015.dwg
Drawing Date: 04/25/15

Load-In Date 20 MARCH, 2015	Load-Out Date 19 APRIL, 2015
--------------------------------	---------------------------------

Power Diagram
Panel PB/Mix

Plate
1.8

Tracy Cowit
Head Sound A1

Sound Designer
Drew Levy

Associate Sound Designer
Maria Wurttele
305.878.0893
wurttele.mf@artist.unca.edu

GUYS AND DOLLS

Venue
STEVENS CENTER

Producer
UNCSA

Director
GUS KAIKKONEN

Production Manager
DENNIS BOOTH

Scenic Designer
GARRET DAUB

Lighting Designer
AL CRAWFORD

Drawn By: TAC
File Name: Guys and Dolls v2015.dwg
Drawing Date: 04/25/15

Load-In Date
20 MARCH, 2015

Load-Out Date
19 APRIL, 2015

Power Diagram
Full Power

Plate
1.9

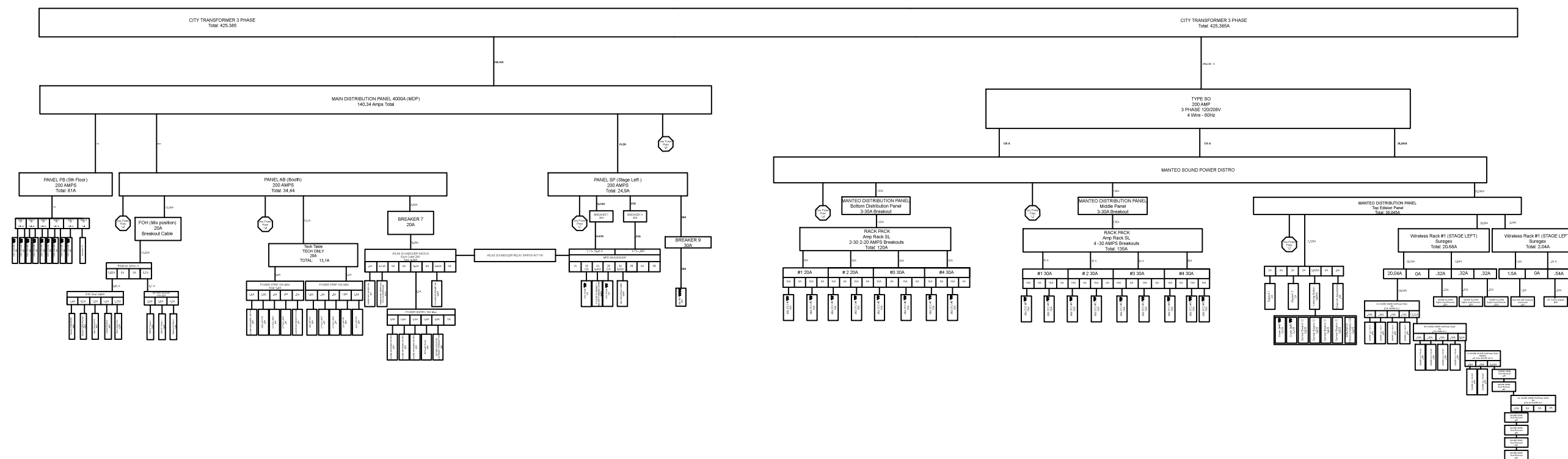

Tracy Cowit

Head Sound A1

Sound Designer
Drew Levy

Associate Sound Designer
Maria Wurttele
305.878.0893
wurttele.mf@artist.uncsa.edu

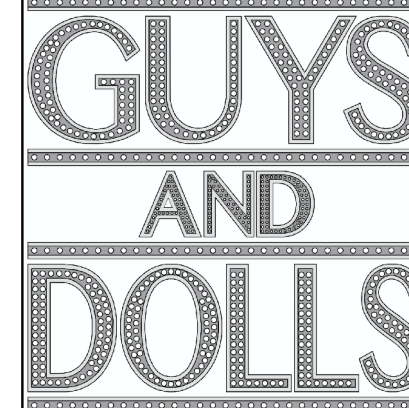

Venue
STEVENS CENTER

Producer
UNCSA

Director
GUS KAIKKONEN

Production Manager
DENNIS BOOTH

Scenic Designer
GARRET DAUB

Lighting Designer
AL CRAWFORD

Drawn By: TAC & GTS
File Name: Guys and Dolls v2015.dwg
Drawing Date: 04/25/15

Load-In Date: 20 MARCH, 2015
Load-Out Date: 19 APRIL, 2015

PATCH PLOT
DIGIRACK 1

Plate
2.2

Reed 1 Flute/Piccolo	Neumann KM184	XLRM	XLRF	Cable	XLRM	XLRF	9pr	GBlockF	Snake A	GBlockF	9pr	XLRM	XLRF	Input 1	SLOT 5	DigiRack 1
Reed 3 Oboe/English Horn	Neumann KM184	XLRM	XLRF	Cable	XLRM	XLRF						XLRM	XLRF	Input 4		
Reed 3 Clarinet	Neumann KM184	XLRM	XLRF	Cable	XLRM	XLRF						XLRM	XLRF	Input 5		
Violin 1/2	Sennheiser MKH800-P48	XLRM	XLRF	Cable	XLRM	XLRF						XLRM	XLRF	Input 1		
Violin 3/4	Sennheiser MKH800-P48	XLRM	XLRF	Cable	XLRM	XLRF						XLRM	XLRF	Input 2		
Violin 5/6	Sennheiser MKH800-P48	XLRM	XLRF	Cable	XLRM	XLRF						XLRM	XLRF	Input 3		
Violin 7/8	Sennheiser MKH800-P48	XLRM	XLRF	Cable	XLRM	XLRF						XLRM	XLRF	Input 4		
Cello 1	DPA 4099-C	XLRM	XLRF	Cable	XLRM	XLRF						XLRM	XLRF	Input 5		
Cello 2	DPA 4099-C	XLRM	XLRF	Cable	XLRM	XLRF	XLRM	XLRF	Input 6							
Reed 1 Alto Sax/Clari	Neumann KM184	XLRM	XLRF	Cable	XLRM	XLRF	9pr	GBlockF	Snake B	GBlockF	9pr	XLRM	XLRF	Input 2	SLOT 5	
Reed 2 Alto Sax/Clari	Neumann KM184	XLRM	XLRF	Cable	XLRM	XLRF						XLRM	XLRF	Input 3		
Reed 3 Tenor Sax	Neumann KM184	XLRM	XLRF	Cable	XLRM	XLRF						XLRM	XLRF	Input 6		
Reed 4 Clarinet	Neumann KM184	XLRM	XLRF	Cable	XLRM	XLRF						XLRM	XLRF	Input 7		
Reed 5 Bari Sax	Neumann KM184	XLRM	XLRF	Cable	XLRM	XLRF						XLRM	XLRF	Input 1		
Reed 5 Bass Clari	Neumann KM184	XLRM	XLRF	Cable	XLRM	XLRF						XLRM	XLRF	Input 2		
Trumpet 1	Sennheiser MD421-II	XLRM	XLRF	Cable	XLRM	XLRF						XLRM	XLRF	Input 4		
Trumpet 2	Sennheiser MD421-II	XLRM	XLRF	Cable	XLRM	XLRF						XLRM	XLRF	Input 5		
Trumpet 3	Sennheiser MD421-II	XLRM	XLRF	Cable	XLRM	XLRF	XLRM	XLRF	Input 6							
Acoustic Bass Mic	Neumann KM184	XLRM	XLRF	Cable	XLRM	XLRF	6pr	GBlockF	Snake C	GBlockF	6pr	XLRM	XLRF	Input 3	SLOT 4	
Reed 4 Tenor Sax	Neumann KM184	XLRM	XLRF	Cable	XLRM	XLRF						XLRM	XLRF	Input 8	SLOT 5	
Trombone	Sennheiser MD421-II	XLRM	XLRF	Cable	XLRM	XLRF						XLRM	XLRF	Input 7	SLOT 6	
French Horn	Sennheiser MD421-II	XLRM	XLRF	Cable	XLRM	XLRF						XLRM	XLRF	Input 8	SLOT 6	
Celesta	AKG C414 B-U1S	XLRM	XLRF	Cable	XLRM	XLRF	12pr	GBlockF	Snake D	GBlockF	12pr	XLRM	XLRF	Input 5	SLOT 4	
Piano Lo	Neumann KM184	XLRM	XLRF	Cable	XLRM	XLRF						XLRM	XLRF	Input 6		
Piano Hi	Neumann KM184	XLRM	XLRF	Cable	XLRM	XLRF						XLRM	XLRF	Input 7		
Kick Out	AKG D112	XLRM	XLRF	Cable	XLRM	XLRF						XLRM	XLRF	Input 2		
Snare	Shure Beta 98D/S	XLRM	XLRF	Cable	XLRM	XLRF	12pr	GBlockF	Snake E	GBlockF	12pr	XLRM	XLRF	Input 3	SLOT 1	
Hi Hat	Neumann KM184	XLRM	XLRF	Cable	XLRM	XLRF						XLRM	XLRF	Input 4		
Tom	Shure Beta 98D/S	XLRM	XLRF	Cable	XLRM	XLRF						XLRM	XLRF	Input 5		
Bells	Neumann KM184	XLRM	XLRF	Cable	XLRM	XLRF						XLRM	XLRF	Input 1		
OH Left	Neumann KM184	XLRM	XLRF	Cable	XLRM	XLRF						XLRM	XLRF	Input 2		
OH Right	Neumann KM184	XLRM	XLRF	Cable	XLRM	XLRF						XLRM	XLRF	Input 3		
Timpani Hi	Neumann KM184	XLRM	XLRF	Cable	XLRM	XLRF						XLRM	XLRF	Input 4		
Timpani Lo	Neumann KM184	XLRM	XLRF	Cable	XLRM	XLRF						XLRM	XLRF	Input 5		
REH Keys L	RCAF	RCAM	Cable	TRS Plug	TRS Jack				Cable	XLRM	XLRF	Input 2	SLOT 7			
REH Keys R	RCAF	RCAM	Cable	TRS Plug	TRS Jack	Radial Duplex			Cable	XLRM	XLRF	Input 3				

Tracy Cowit

Head Sound A1

Sound Designer
Drew Levy

Associate Sound Designer

Maria Wurttele

305.878.0893

wurttele.mf@artist.uncsa.edu

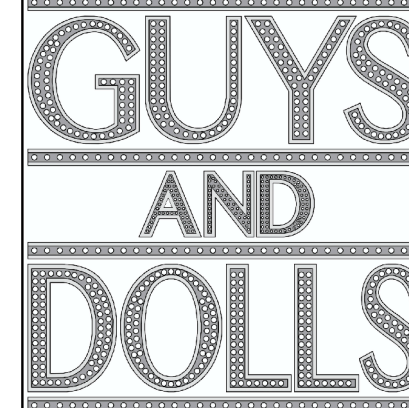

Venue

STEVENS CENTER

Producer

UNCSA

Director

GUS KAIKKONEN

Production Manager

DENNIS BOOTH

Scenic Designer

GARRET DAUB

Lighting Designer

AL CRAWFORD

Drawn By: TAC & GTS
File Name: Guys and Dolls v2015.dwg
Drawing Date: 04/25/15

Load-In Date 20 MARCH, 2015	Load-Out Date 19 APRIL, 2015
--------------------------------	---------------------------------

PATCH PLOT
DIGIRACK 2 INPUTS

Plate
2.3

1	Michael Calciano	Benny	Countryma	Cable	TA-4F	TA-4M	1	ULXD Transmitter H50	578.625	ULXD Receiver*	Output	XLRM
2	Nickolaus Colon	Nathan	Countryma	Cable	TA-4F	TA-4M	2	ULXD Transmitter H50	587.175		Output	XLRM
3	Ashley Powers	General	Countryma	Cable	TA-4F	TA-4M	3	ULXD Transmitter H50	593.1		Output	XLRM
4	Benton Guinness	Harry the	Countryma	Cable	TA-4F	TA-4M	4	ULXD Transmitter H50	595.625	ULXD Receiver*	Output	XLRM
5	Kyle Habberstad	Sky	Countryma	Cable	TA-4F	TA-4M	5	ULXD Transmitter H50	536.575		Output	XLRM
6	Michael Johnson	Lt.	Countryma	Cable	TA-4F	TA-4M	6	ULXD Transmitter H50	537.175		Output	XLRM
7	Steven Maier	MC, Angie	Countryma	Cable	TA-4F	TA-4M	7	ULXD Transmitter H50	564.075	ULXD Receiver*	Output	XLRM
8	Josh Popa	Nicely Nicely	Countryma	Cable	TA-4F	TA-4M	8	ULXD Transmitter H50	566.45		Output	XLRM
9	Noah Reece	Rusty	Countryma	Cable	TA-4F	TA-4M	9	ULXD Transmitter H50	535.275		Output	XLRM
10	Graham Baker	Male Ens. 2	Countryma	Cable	TA-4F	TA-4M	26	ULXD Transmitter H50	535.85	ULXD Receiver*	Output	XLRM
11	Sam Geoffrey	Male Ens. 3	Countryma	Cable	TA-4F	TA-4M	27	ULXD Transmitter H50	545.975		Output	XLRM
							Spare 1	ULXD Transmitter H50	FREQ.		Output	XLRM
12	Meagan Smith	Adelaide	Countryma	Cable	TA-4F	TA-4M	10	UR1-M Transmitter g1	518.925	UR4D Receiver*	Output	XLRM
13	Jasmine Stiefel	Martha	Countryma	Cable	TA-4F	TA-4M	11	UR1-M Transmitter g1	524.8		Output	XLRM
14	Kira Geiger	Sarah Brown	Countryma	Cable	TA-4F	TA-4M	12	UR1-M Transmitter g1	507.25		Output	XLRM
15	Rachel Brooks	Agatha	Countryma	Cable	TA-4F	TA-4M	13	UR1-M Transmitter g1	513.4	UR4D Receiver*	Output	XLRM
16	Samaria Pagge	Mimi (ens.)	Countryma	Cable	TA-4F	TA-4M	14	UR1-M Transmitter g1	477.25		Output	XLRM
17	Emily Hart	Female Ens.	Countryma	Cable	TA-4F	TA-4M	15	UR1-M Transmitter g1	486.575		Output	XLRM
18	Caroline Annichiarco	Female Ens.	Countryma	Cable	TA-4F	TA-4M	16	UR1-M Transmitter g1	472.625	UR4D Receiver*	Output	XLRM
19	Courtnee Carter	Female Ens.	Countryma	Cable	TA-4F	TA-4M	17	UR1-M Transmitter g1	472.975		Output	XLRM
20	Beth Hawkes	Female Ens.	Countryma	Cable	TA-4F	TA-4M	18	UR1-M Transmitter g1	470.35		Output	XLRM
21	Savannah-Lee Mumford	Female Ens.	Countryma	Cable	TA-4F	TA-4M	19	UR1-M Transmitter g1	472.1	UR4D Receiver*	Output	XLRM
22	Chessa Metz	Female Ens.	Countryma	Cable	TA-4F	TA-4M	20	UR1-M Transmitter g1	512.225		Output	XLRM
							Spare 2	UR1-M Transmitter g1	FREQ.		Output	XLRM
23	Jonathan Downey	Calvin	Countryma	Cable	TA-4F	TA-4M	21	ULXS Transmitter (M1)	662.125	ULX Receiver (M1)*	Output	XLRM
24	Mason Hensley	Arvide	Countryma	Cable	TA-4F	TA-4M	22	ULXS Transmitter (M1)	663.05		Output	XLRM
25	TJ Nelson	Joey	Countryma	Cable	TA-4F	TA-4M	23	ULXS Transmitter (M1)	663.725		Output	XLRM
26	Luis Quintero	Big Jule	Countryma	Cable	TA-4F	TA-4M	24	ULXS Transmitter (M1)	665.757	ULX Receiver (M1)*	Output	XLRM
27	Andrew Manning	Male Ens. 1	Countryma	Cable	TA-4F	TA-4M	25	ULXS Transmitter (M1)	537.175		Output	XLRM
							Spare 3	ULXS Transmitter (M1)	FREQ.		Output	XLRM
28	Stephen Kime	Male Ens. 4	Countryma	Cable	TA-4F	TA-4M	28	ULXS Transmitter (J1)	556.375	ULX Receiver (J1)*	Output	XLRM
29	Joshua Pagan	Male Ens. 5	Countryma	Cable	TA-4F	TA-4M	29	ULXS Transmitter (J1)	557.675		Output	XLRM
30	Isaac Powell	Male Ens. 6	Countryma	Cable	TA-4F	TA-4M	30	ULXS Transmitter (J1)	567.6		Output	XLRM
							Spare 4	ULXS Transmitter (J1)	FREQ.	Output	XLRM	
							Spare 5	ULXS Transmitter (J1)	FREQ.	Output	XLRM	
							Tap Mic 1	PCC 160	TA-3M	TA-3F*	Cable	XLRM
							Tap Mic 2	PCC 160	TA-3M	TA-3F*	Cable	XLRM
							Tap Mic 3	PCC 160	TA-3M	TA-3F*	Cable	XLRM
							Tap Mic 4	PCC 160	TA-3M	TA-3F*	Cable	XLRM
										Offstage Mic*	SM58	XLRM

ULXD Receiver*	Output	XLRM	XLR F	(15') 12-ch XLR Snake (SL SNAKE #1)	XLRM	XLRF	Input 1	SLOT 1		
	Output	XLRM	XLR F		XLRM	XLRF	Input 2			
	Output	XLRM	XLR F		XLRM	XLRF	Input 3			
ULXD Receiver*	Output	XLRM	XLR F		XLRM	XLRF	Input 4			
	Output	XLRM	XLR F		XLRM	XLRF	Input 5			
	Output	XLRM	XLR F		XLRM	XLRF	Input 6			
ULXD Receiver*	Output	XLRM	XLR F		(15') 8-ch XLR Snake (SL SNAKE #3)	XLRM	XLRF		Input 7	SLOT 2
	Output	XLRM	XLR F			XLRM	XLRF		Input 8	SLOT 4
	Output	XLRM	XLR F			(SL SNAKE #1)	XLRM	XLRF	Input 4	SLOT 2
UR4D Receiver*	Output	XLRM	XLR F		(15') 12-ch XLR Snake (SL SNAKE #2)	XLRM	XLRF	Input 5	SLOT 2	
	Output	XLRM	XLR F			XLRM	XLRF	Input 6		
UR4D Receiver*	Output	XLRM	XLR F			XLRM	XLRF	Input 7		
	Output	XLRM	XLR F	XLRM		XLRF	Input 8			
UR4D Receiver*	Output	XLRM	XLR F	XLRM		XLRF	Input 1	SLOT 3		
	Output	XLRM	XLR F	XLRM		XLRF	Input 2			
UR4D Receiver*	Output	XLRM	XLR F	XLRM		XLRF	Input 3			
	Output	XLRM	XLR F	XLRM		XLRF	Input 4			
UR4D Receiver*	Output	XLRM	XLR F	XLRM		XLRF	Input 5			
	Output	XLRM	XLR F	XLRM		XLRF	Input 6			
UR4D Receiver*	Output	XLRM	XLR F	XLRM		XLRF	Input 7			
	Output	XLRM	XLR F	XLRM		XLRF	Input 8			
ULX Receiver (M1)*	Output	XLRM	XLR F	(15') 8-ch XLR Snake (SL SNAKE #3)	XLRM	XLRF	Input 1	SLOT 4		
	Output	XLRM	XLR F		XLRM	XLRF	Input 2			
ULX Receiver (M1)*	Output	XLRM	XLR F		XLRM	XLRF	Input 3			
	Output	XLRM	XLR F		XLRM	XLRF	Input 4			
ULX Receiver (M1)*	Output	XLRM	XLR F		XLRM	XLRF	Input 5			
	Output	XLRM	XLR F		XLRM	XLRF	Input 6			
ULX Receiver (J1)*	Output	XLRM	XLR F		(15') 8-ch XLR Snake (SL SNAKE #4)	XLRM	XLRF	Input 1	SLOT 5	
	Output	XLRM	XLR F			XLRM	XLRF	Input 2		
ULX Receiver (J1)*	Output	XLRM	XLR F			XLRM	XLRF	Input 3		
	Output	XLRM	XLR F			XLRM	XLRF	Input 4		
ULX Receiver (J1)*	Output	XLRM	XLR F			XLRM	XLRF	Input 5		
	Output	XLRM	XLR F			XLRM	XLRF	Input 6		
TA-3F*	Cable	XLRM	XLRF	Cable		XLRM	XLRF	Input 6	SLOT 6	
TA-3F*	Cable	XLRM	XLRF	Cable		XLRM	XLRF	Input 1		
TA-3F*	Cable	XLRM	XLRF	Cable		XLRM	XLRF	Input 2		
TA-3F*	Cable	XLRM	XLRF	Cable		XLRM	XLRF	Input 3		
Offstage Mic*	SM58	XLRM	XLRF	Cable		XLRM	XLRF	Input 4		

Tracy Cowit

Head Sound A1

Sound Designer

Drew Levy

Associate Sound Designer

Maria Wurttele

305.878.0893

wurttele.mf@artist.uncsa.edu

**GUYS
AND
DOLLS**

Venue

STEVENS CENTER

Producer

UNCSA

Director

GUS KAIKKONEN

Production Manager

DENNIS BOOTH

Scenic Designer

GARRET DAUB

Lighting Designer

AL CRAWFORD

Drawn By: TAC & GTS

File Name: Guys and Dolls v2015.dwg

Drawing Date: 04/25/15

Load-In Date

20 MARCH, 2015

Load-Out Date

19 APRIL, 2015

**PATCH PLOT
DIGIRACK 2 INPUTS**

Plate
2.4

Tracy Cowit

Head Sound A1

Sound Designer
Drew Levy

Associate Sound Designer
Maria Wurttele

305.878.0893

wurttele.mf@artist.uncsa.edu

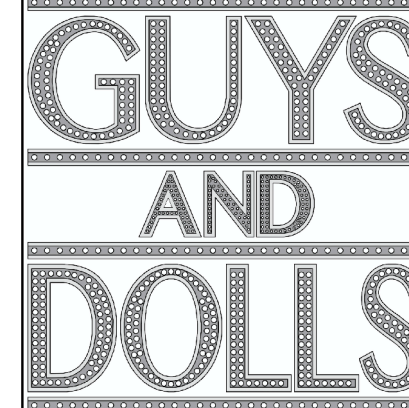

Venue

STEVENS CENTER

Producer

UNCSA

Director

GUS KAIKKONEN

Production Manager

DENNIS BOOTH

Scenic Designer

GARRET DAUB

Lighting Designer

AL CRAWFORD

Drawn By: TAC & GTS

File Name: Guys and Dolls v2015.dwg

Drawing Date: 04/25/15

Load-In Date

20 MARCH, 2015

Load-Out Date

19 APRIL, 2015

PATCH PLOT
DIGIRACK 2 OUTPUTS

Plate
2.5

Slot 8	Output 1	XLR M	XLR F	Cable	XLR M	XLR F	D80.1.A	d&b D12 #1	Ch. A Out	NL4MP	NL4FC	Cable	NL4FC	NL4MP	d&b Y8	Center Cluster 1*	
									Ch. B Out	NL4MP	NL4FC	Cable	NL4FC	NL4MP	d&b Y8	Center Cluster 2*	
									Ch. C Out	NL4MP	NL4FC	Cable	NL4FC	NL4MP	d&b Y8	Center Cluster 3*	
									Ch. D Out	NL4MP	NL4FC	Cable	NL4FC	NL4MP	d&b Y8	Center Cluster 5*	
	Output 2	XLR M	XLR F	Cable	XLR M	XLR F	D12.1.A	d&b D12 #1	Ch. A Out	NL4MP	NL4FC	Cable	NL4FC	NL4MP	NL8MP	NL8FC*	
									Ch. B Out	NL4MP	NL4FC	Cable	NL4FC	NL4MP			
	Output 4	XLR M	XLR F	Cable	XLR M	XLR F	D12.2.B	d&b D12 #2	Ch. B Out	NL4MP	NL4FC	Cable	NL4FC	NL4MP			
	Output 5	XLR M	XLR F	Cable	XLR M	XLR F	D12.3.A	d&b D12 #3	Ch. A Out	NL4MP	NL4FC	Cable	NL4FC	NL4MP	d&b C7-TOP	Main Orch L*	
Output 6	XLR M	XLR F	Cable	XLR M	XLR F	D12.3.B	Ch. B Out		NL4MP	NL4FC	Cable	NL4FC	NL4MP	d&b C7-TOP	Main Orch R*		
Output 7	XLR M	XLR F	Cable	XLR M	XLR F	D12.4.A	d&b D12 #4	Ch. A Out	NL4MP	NL4FC	Cable	NL4FC	NL4MP	d&b C7-TOP	Main Balc L*		
Output 8	XLR M	XLR F	Cable	XLR M	XLR F	D12.4.B		Ch. B Out	NL4MP	NL4FC	Cable	NL4FC	NL4MP	d&b C7-TOP	Main Balc R*		
Slot 9	Output 1	XLR M	XLR F	Cable	XLR M	XLR F	D12.5.A	d&b D12 #5	Ch. A Out	NL4MP	NL4FC	Cable	NL4FC	NL4MP	d&b E3	Front Fill 1*	
	Output 2	XLR M	XLR F	Cable	XLR M	XLR F	D12.5.B		Ch. B Out	NL4MP	NL4FC	Cable	NL4FC	NL4MP	d&b E3	Front Fill 2*	
	Output 3	XLR M	XLR F	Cable	XLR M	XLR F	D12.6.A	d&b D12 #6	Ch. A Out	NL4MP	NL4FC	Cable	NL4FC	NL4MP	d&b E3	Front Fill 4*	
	Output 4	XLR M	XLR F	Cable	XLR M	XLR F	D12.7.A		Ch. A Out	NL4MP	NL4FC	Cable	NL4FC	NL4MP	d&b E8	UnderBalc L*	
	Output 5	XLR M	XLR F	Cable	XLR M	XLR F	D12.7.B	d&b D12 #7	Ch. B Out	NL4MP	NL4FC	Cable	NL4FC	NL4MP	d&b E8	UnderBalc C*	
	Output 6	XLR M	XLR F	Cable	XLR M	XLR F	D12.8.A		Ch. A Out	NL4MP	NL4FC	Cable	NL4FC	NL4MP	d&b E8	UnderBalc R*	
Slot 10	Output 1	XLR M	XLR F	Cable	XLR M	XLR F	D12.9.A	d&b D12 #9	Ch. A Out	NL4MP	NL4FC	Cable	NL4FC	NL4MP	d&b E5	BalcFill 1*	
	Output 2	XLR M	XLR F	Cable	XLR M	XLR F	D12.9.B		Ch. B Out	NL4MP	NL4FC	Cable	NL4FC	NL4MP	d&b E5	BalcFill 3*	
	Output 3	XLR M	XLR F	Cable	XLR M	XLR F	D12.10.A	d&b D12 #10	Ch. A Out	NL4MP	NL4FC	Cable	NL4FC	NL4MP	d&b E5	BalcFill 6*	
Slot 11	Output 1	XLR M	XLR F	Cable	XLR M	XLR F	Wall Plate 41	House Wire	Booth Patchbay	Mic Line 41	Military F	Military M	Cable	XLRM	XLRF	EPAC #1*	
	Output 2	XLR M	XLR F	Cable	XLR M	XLR F	D12.11.A	d&b D12 #11	Ch. A Out	NL4MP	NL4FC	Cable	NL4FC	NL4MP	NL8MP	NL8FC*	
	Output 4	XLR M	XLR F	Cable	XLR M	XLR F	D12.12.A		Ch. A Out	NL4MP	NL4FC	Cable	NL4FC	NL4MP			
	Output 6	XLR M	XLR F	Cable	XLR M	XLR F	D12.13.A	d&b D12 #13	Ch. A Out	NL4MP	NL4FC	Cable	NL4FC	NL4MP	NL8MP	NL8FC*	
	Output 3	XLR M	XLR F	Cable	XLR M	XLR F	D12.11.B		d&b D12 #11	Ch. B Out	NL4MP	NL4FC	Cable	NL4FC			NL4MP
	Output 5	XLR M	XLR F	Cable	XLR M	XLR F	D12.12.B	d&b D12 #12	Ch. B Out	NL4MP	NL4FC	Cable	NL4FC	NL4MP	NL8MP	NL8FC*	
	Output 7	XLR M	XLR F	Cable	XLR M	XLR F	D12.13.B		Ch. B Out	NL4MP	NL4FC	Cable	NL4FC	NL4MP			
	Output 8	XLR M	XLR F	Cable	XLR M	XLR F	D12.14.A	d&b D12 #14	Ch. A Out	NL4MP	NL4FC	Cable	NL4FC	NL4MP			
Slot 12	Output 1	XLRM	XLRF	Cable	XLRM	XLRF	SL Patchbay	House Wire	Booth Military Patchbay	Military F	Military M	Cable	Military M	Military F	Booth Military Patchbay (behind)	XLR M*	
	Output 2	XLRM	XLRF	Cable	XLRM	XLRF				Military F	Military M	Cable	Military M	Military F		XLR M*	
	Output 3	XLRM	XLRF	Cable	XLRM	XLRF				Military F	Military M	Cable	Military M	Military F		XLR M*	
	Output 4	XLRM	XLRF	Cable	XLRM	XLRF				Military F	Military M	Cable	Military M	Military F		XLR M*	
	Output 6	XLR M	XLR F	Cable	XLR M	XLR F	D12.16.A	d&b D12 #16	Ch. A Out	NL4MP	NL4FC	Cable	NL4FC	NL4MP Turnaround	NL4FC	Cable*	
Output 7	XLR M	XLR F	Cable	XLR M	XLR F	D12.15.A	d&b D12 #15	Ch. A Out	NL4MP	NL4FC	Cable	NL4FC	NL4MP	EAW JF60	Offstage Monitor 1*		
									Ch. B Out	NL4MP	NL4FC	Cable	NL4FC	NL4MP	d&b E0	Offstage Monitor 3*	

Tracy Cowit

Head Sound A1

Sound Designer
Drew Levy

Associate Sound Designer

Maria Wurttele

305.878.0893

wurttele.mf@artist.uncsa.edu

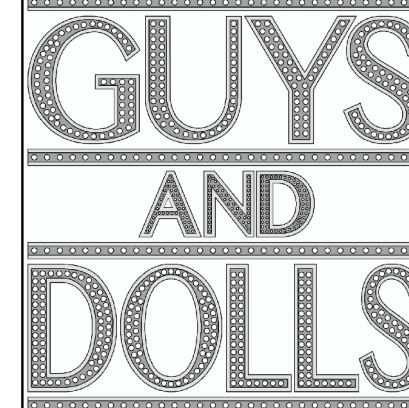

Venue

STEVENS CENTER

Producer

UNCSA

Director

GUS KAIKKONEN

Production Manager

DENNIS BOOTH

Scenic Designer

GARRET DAUB

Lighting Designer

AL CRAWFORD

Drawn By: TAC & GTS

File Name: Guys and Dolls v2015.dwg

Drawing Date: 04/25/15

Load-In Date

20 MARCH, 2015

Load-Out Date

19 APRIL, 2015

PATCH PLOT
DIGIRACK 2 OUTPUTS

Plate
2.6

Center Cluster 1*											
Center Cluster 2*											
Center Cluster 3*	NL4MP	NL4FC	Cable	NL4FC	NL4MP	d&b Y8	Center Cluster 4				
Center Cluster 5*	NL4MP	NL4FC	Cable	NL4FC	NL4MP	d&b Y8	Center Cluster 6				
NL8FC*	Cable	NL8FC	NL8MP	NL4FC	NL4 Turnaround	NL4FC	Cable	NL4FC	NL4MP	d&b Q1	Delay Array 1*
				NL4FC	NL4 Turnaround	NL4FC	Cable	NL4FC	NL4MP	d&b Q1	Delay Array 3*
				NL4FC	NL4 Turnaround	NL4FC	Cable	NL4FC	NL4MP	d&b V-Sub	Sub L*
Main Orch L*											
Main Orch R*											
Main Balc L*											
Main Balc R*											
Front Fill 1*											
Front Fill 2*	NL4MP	NL4FC	Cable	NL4FC	NL4MP	d&b E3	Front Fill 3				
Front Fill 4*											
UnderBalc L*											
UnderBalc C*											
UnderBalc R*											
BalcFill 1*	NL4MP	NL4FC	Cable	NL4FC	NL4MP	d&b E5	BalcFill 2				
BalcFill 3*	NL4MP	NL4FC	Cable	NL4FC	NL4MP	d&b E5	BalcFill 4	NL4MP	NL4FC	Cable	NL4FC*
BalcFill 6*	NL4MP	NL4FC	Cable	NL4FC	NL4MP	d&b E5	BalcFill 7				
EPAC #1*	EPAC	Output	NL4MP	NL4FC	Cable	NL4FC	NL4MP	d&b E3	Mix Fill		
NL8FC*	Cable	NL8FC	NL8MP	NL4FC	NL4 Turnaround	NL4FC	Cable	NL4FC	NL4MP	d&b E8	FoldBack DSR*
				NL4FC	NL4 Turnaround	NL4FC	Cable	NL4FC	NL4MP	d&b E8	FoldBack MSR*
				NL4FC	NL4 Turnaround	NL4FC	Cable	NL4FC	NL4MP	d&b E8	FoldBack USR*
NL8FC*	Cable	NL8FC	NL8MP	NL4FC	NL4 Turnaround	NL4FC	Cable	NL4FC	NL4MP	d&b E8	FoldBack DSL*
				NL4FC	NL4 Turnaround	NL4FC	Cable	NL4FC	NL4MP	d&b E8	FoldBack MSL*
				NL4FC	NL4 Turnaround	NL4FC	Cable	NL4FC	NL4MP	d&b E8	FoldBack USL*
XLR M*	XLR F	Cable	XLR M	XLR F 1	House Snake	XLR M 1	XLRF 1	Ch. 1 Input	QSC USA 900 Amp 4	Binding Post	Barewire*
		Cable	XLR M	XLR F 2		XLR M 5	XLRF 5	Ch. 1 Input	QSC USA 900 Amp 6	Binding Post	Barewire*
		XLR F 3				XLR M 3	XLRF 3	Ch. 1 Input	QSC USA 900 Amp 5	Binding Post	Barewire*
XLR F 4			XLR M 4	XLRF 4		Ch. 2 Input	Binding Post	Barewire*			
XLR M*	XLR F	Cable	XLR M	XLR F 5		XLR M 2	XLRF 2	Ch. 2 Input	QSC USA 900 Amp 4	Binding Post	Barewire*
		Cable	XLR M	XLR F 6		XLR M 6	XLRF 6	Ch. 2 Input	QSC USA 900 Amp 6	Binding Post	Barewire*
Cable*	TRS Plug	TRS Jack	Hotspot	Conductor Monitor							
Offstage Monitor 1*	NL4MP	NL4FC	Cable	NL4FC	NL4MP	EAW JF60	Offstage Monitor 2				
Offstage Monitor 3*	NL4MP	NL4FC	Cable	NL4FC	NL4MP	d&b E0	Offstage Monitor 4				

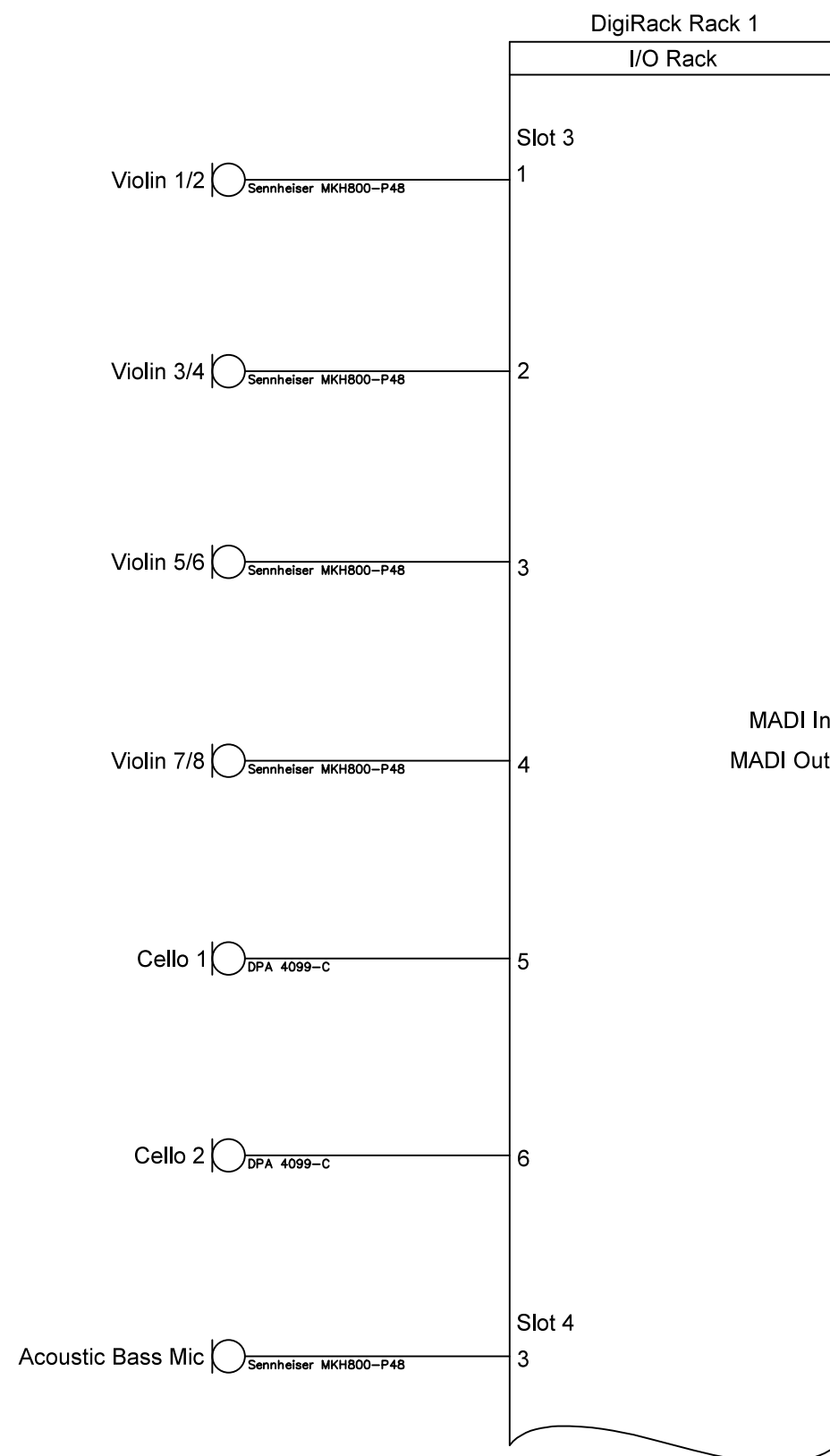
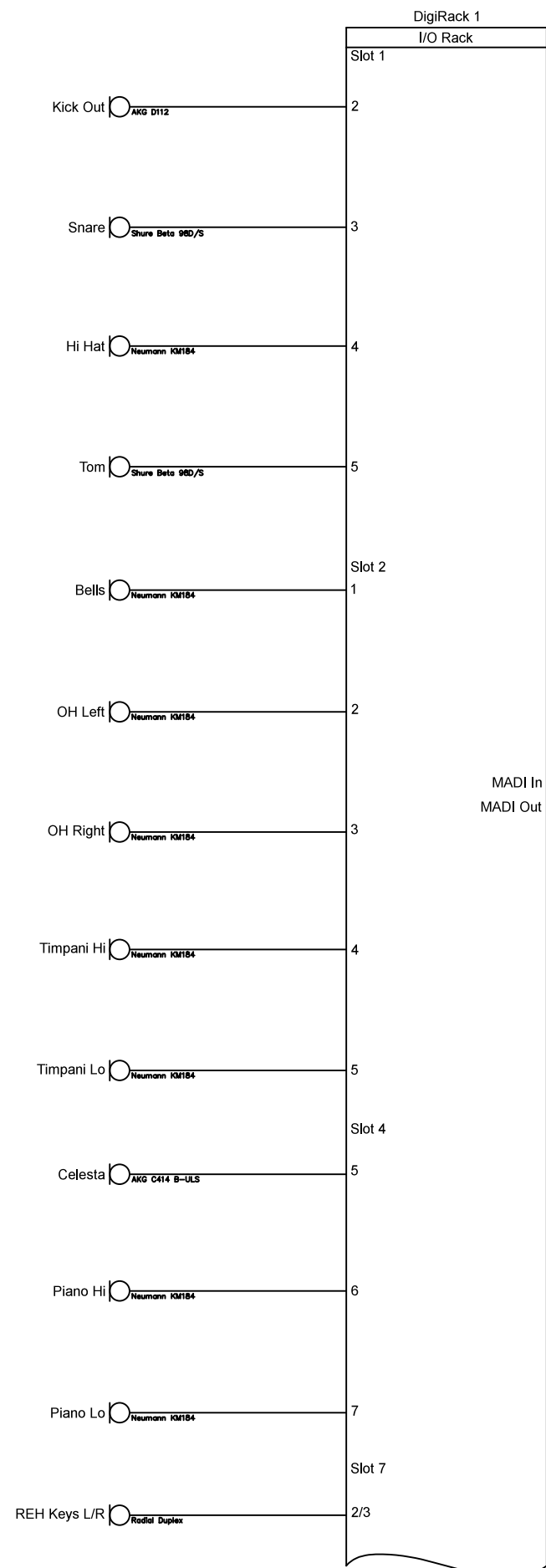

Tracy Cowit

Head Sound A1

Sound Designer
Drew Levy

Associate Sound Designer

Maria Wurttele

305.878.0893

wurttele.mf@artist.uncsa.edu

**GUYS
AND
DOLLS**

Venue

STEVENS CENTER

Producer

UNCSA

Director

GUS KAIKKONEN

Production Manager

DENNIS BOOTH

Scenic Designer

GARRET DAUB

Lighting Designer

AL CRAWFORD

Drawn By: TAC & GTS

File Name: Guys and Dolls v2015.dwg

Drawing Date: 04/25/15

Load-In Date

20 MARCH, 2015

Load-Out Date

19 APRIL, 2015

**ONE LINE
DIGIRACK 1 I/O**

Plate
3.1

Tracy Cowit

Head Sound A1

Sound Designer

Drew Levy

Associate Sound Designer

Maria Wurttele

305.878.0893

wurttele.mf@artist.uncsa.edu

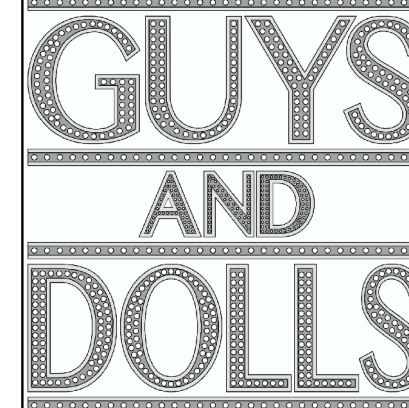

Venue

STEVENS CENTER

Producer

UNCSA

Director

GUS KAIKKONEN

Production Manager

DENNIS BOOTH

Scenic Designer

GARRET DAUB

Lighting Designer

AL CRAWFORD

Drawn By: TAC & GTS

File Name: Guys and Dolls v2015.dwg

Drawing Date: 04/25/15

Load-In Date

20 MARCH, 2015

Load-Out Date

19 APRIL, 2015

ONE LINE
DigiRack 1 I/O

Plate
3.2

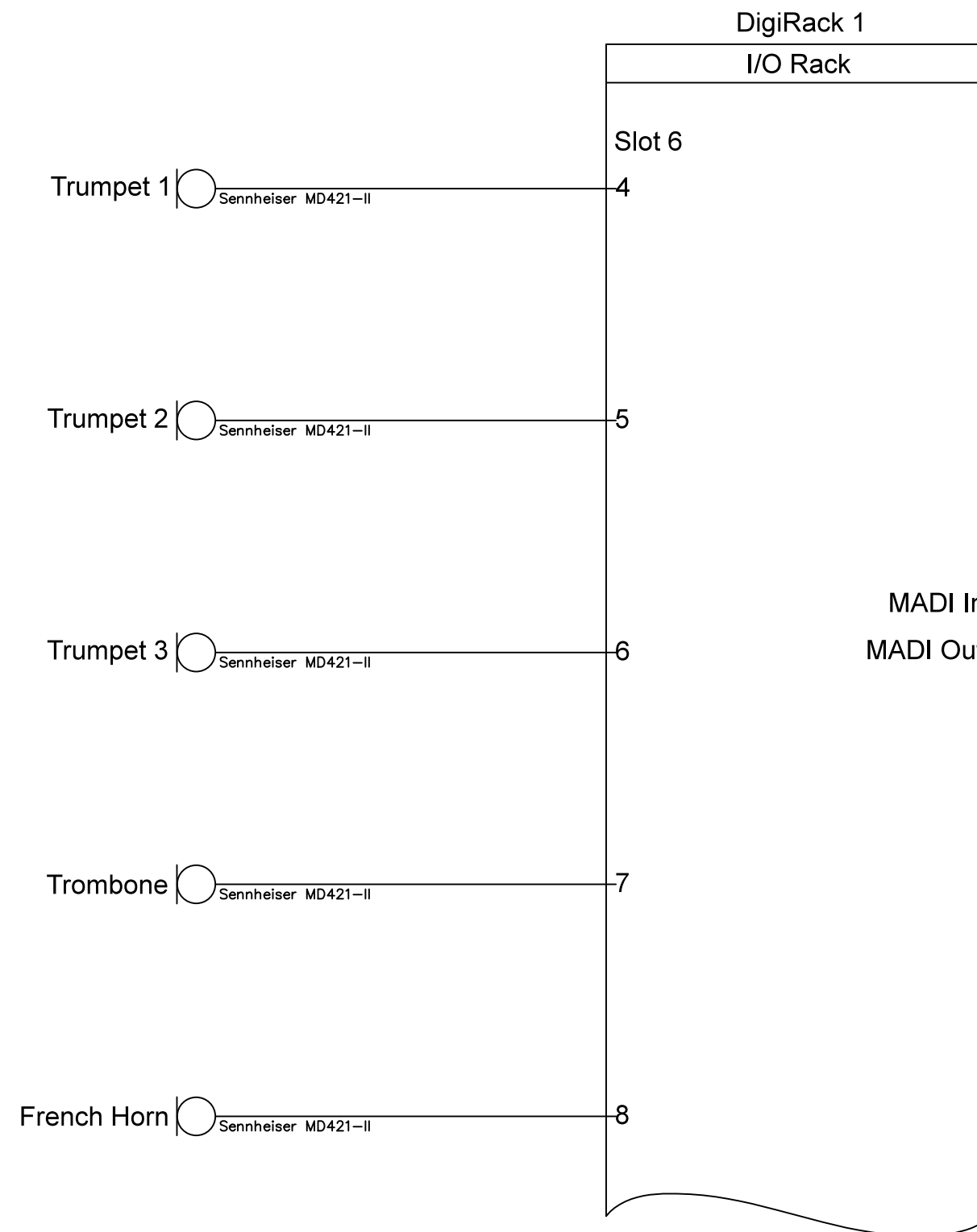
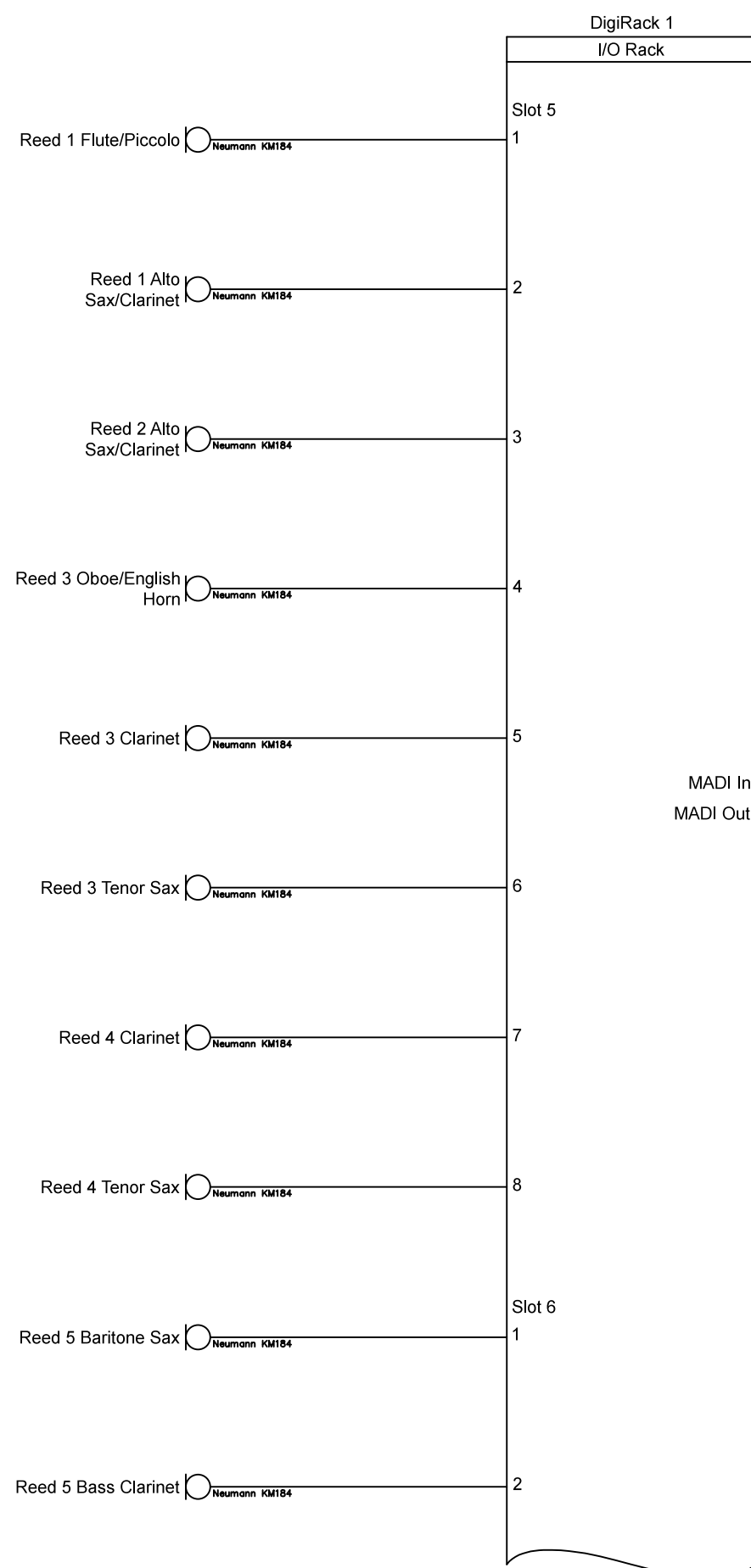

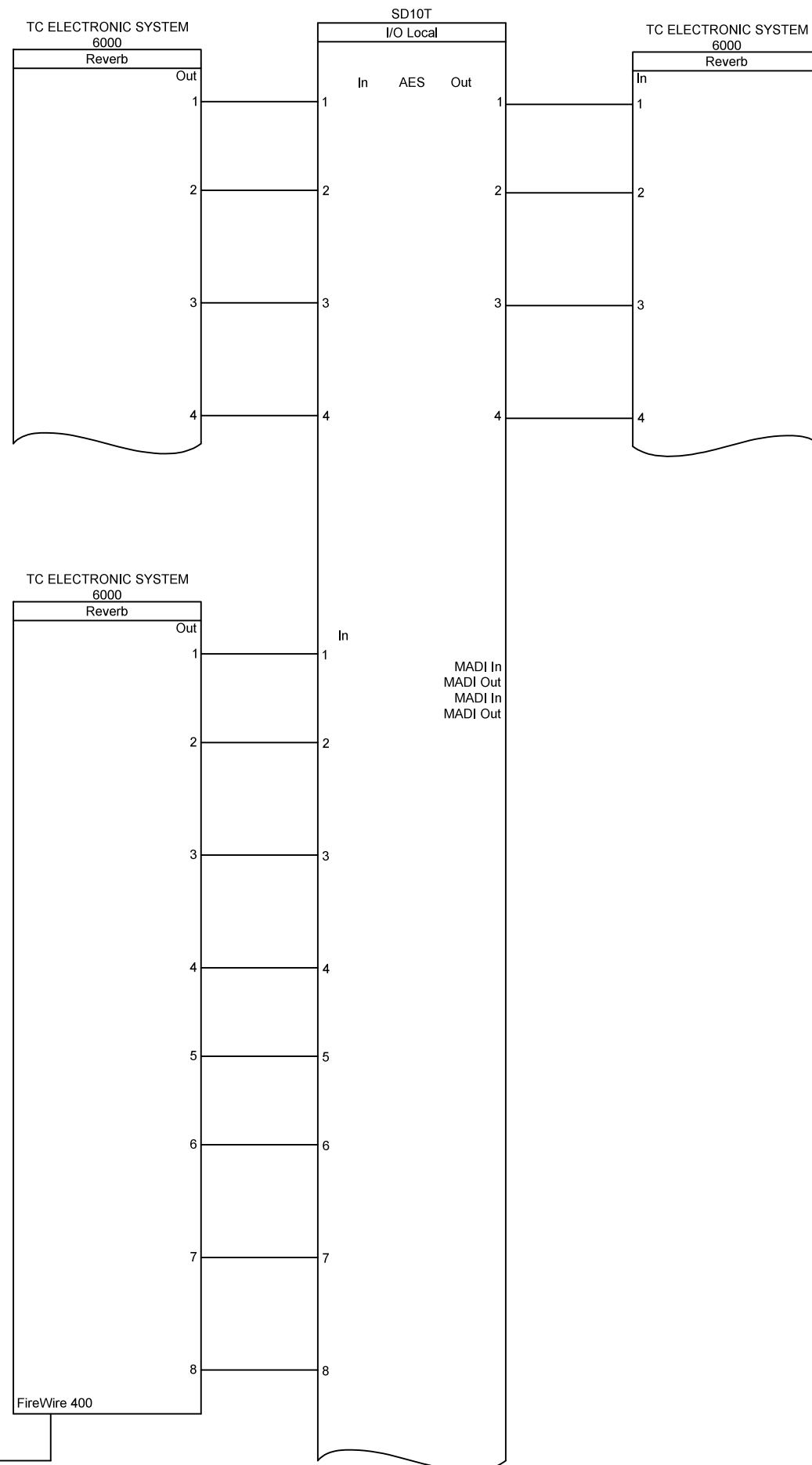
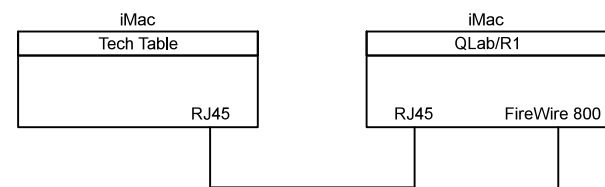

Tracy Cowit

Head Sound A1

Sound Designer
Drew Levy

Associate Sound Designer
Maria Wurttle

305.878.0893
wurttle.mf@artist.uncsa.edu

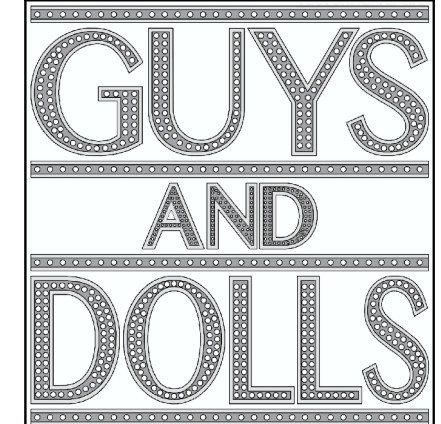

Venue

STEVENS CENTER

Producer

UNCSA

Director

GUS KAIKKONEN

Production Manager

DENNIS BOOTH

Scenic Designer

GARRET DAUB

Lighting Designer

AL CRAWFORD

Drawn By: TAC & GTS
File Name: Guys and Dolls v2015.dwg
Drawing Date: 04/25/15

Load-In Date 20 MARCH, 2015	Load-Out Date 19 APRIL, 2015
--------------------------------	---------------------------------

ONE LINE
SD10T LOCAL I/O

Plate
3.3

Tracy Cowit

Head Sound A1

Sound Designer
Drew Levy

Associate Sound Designer
Maria Wurttele

305.878.0893

wurttele.mf@artist.uncsa.edu

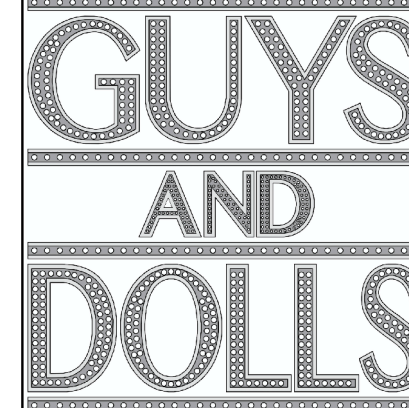

Venue

STEVENS CENTER

Producer

UNCSA

Director

GUS KAIKKONEN

Production Manager

DENNIS BOOTH

Scenic Designer

GARRET DAUB

Lighting Designer

AL CRAWFORD

Drawn By: TAC & GTS
File Name: Guys and Dolls v2015.dwg
Drawing Date: 04/25/15

Load-In Date 20 MARCH, 2015	Load-Out Date 19 APRIL, 2015
--------------------------------	---------------------------------

ONE LINE
DIGIRACK 2- Wireless I/O

Plate
3.4

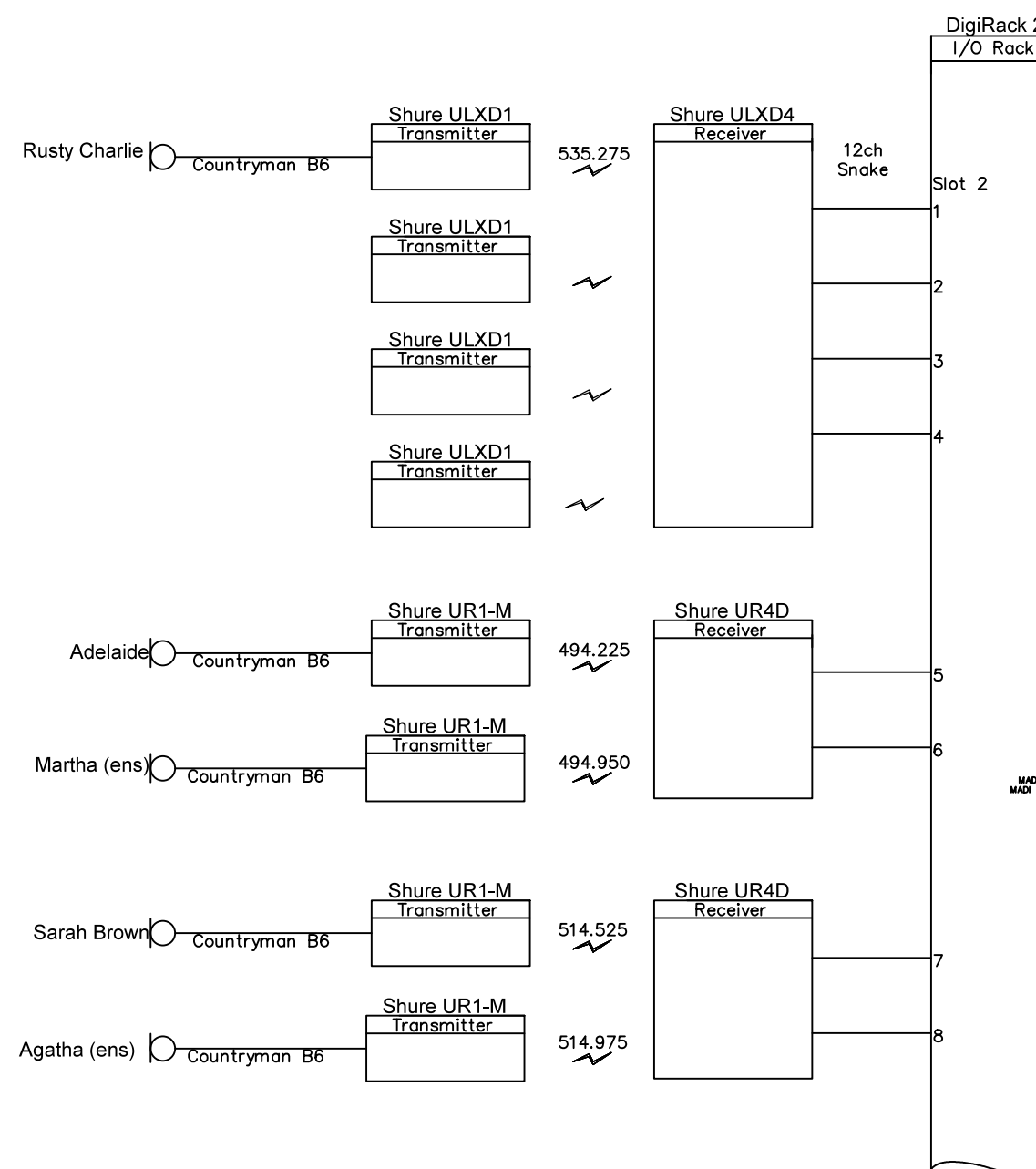
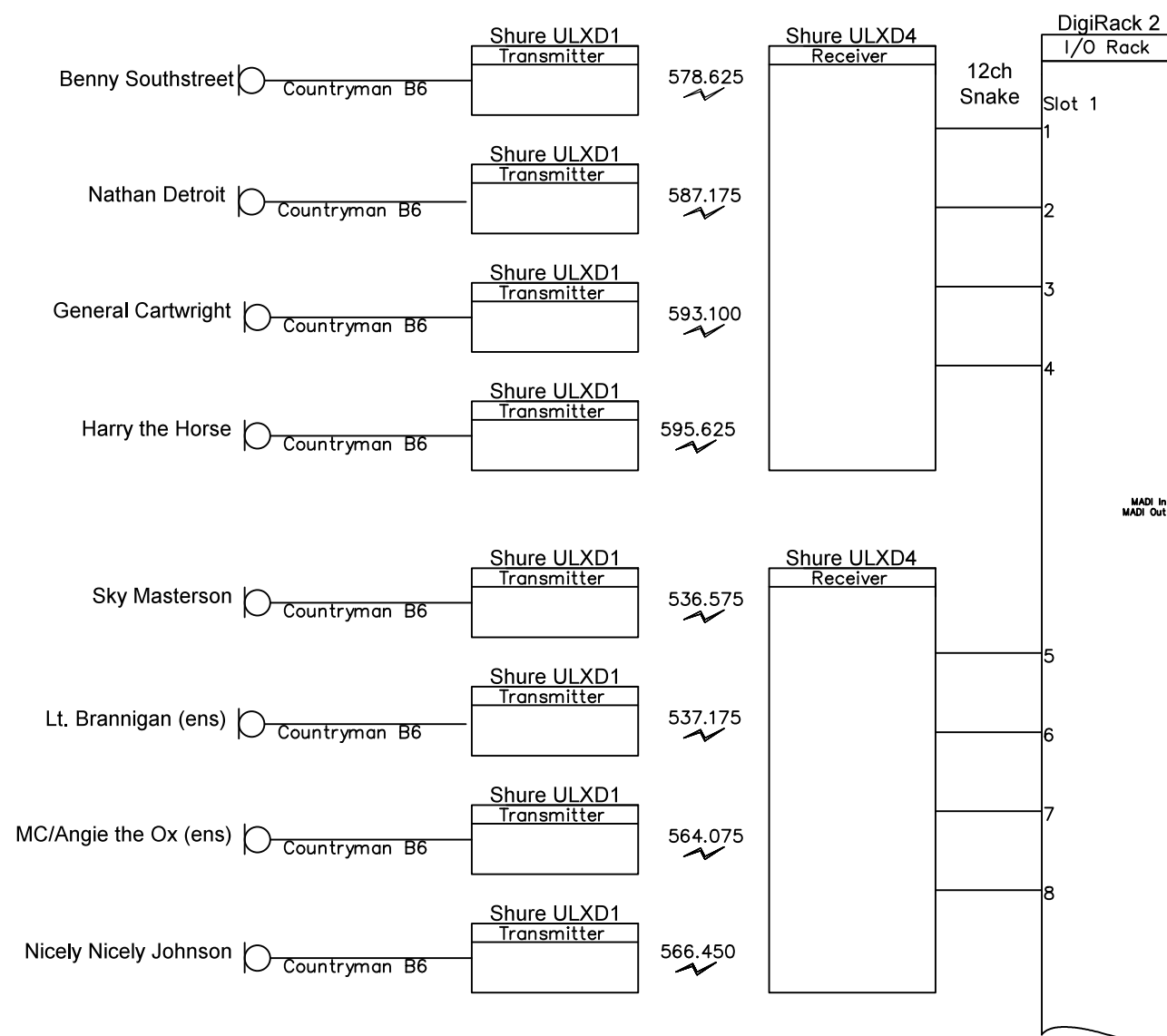

Tracy Cowit

Head Sound A1

Sound Designer
Drew Levy

Associate Sound Designer
Maria Wurttle

305.878.0893

wurttle.mf@artist.uncsa.edu

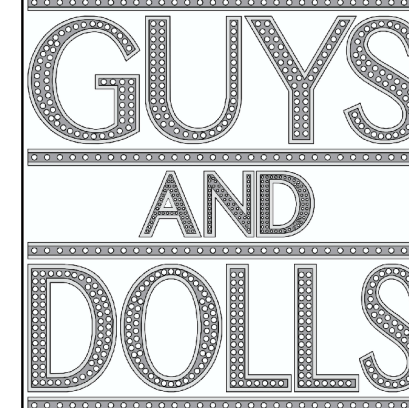

Venue

STEVENS CENTER

Producer

UNCSA

Director

GUS KAIKKONEN

Production Manager

DENNIS BOOTH

Scenic Designer

GARRET DAUB

Lighting Designer

AL CRAWFORD

Drawn By: TAC & GTS

File Name: Guys and Dolls v2015.dwg

Drawing Date: 04/25/15

Load-In Date

20 MARCH, 2015

Load-Out Date

19 APRIL, 2015

ONE INE
DIGIRACK 2 - WIRELESS I/O

Plate
3.5

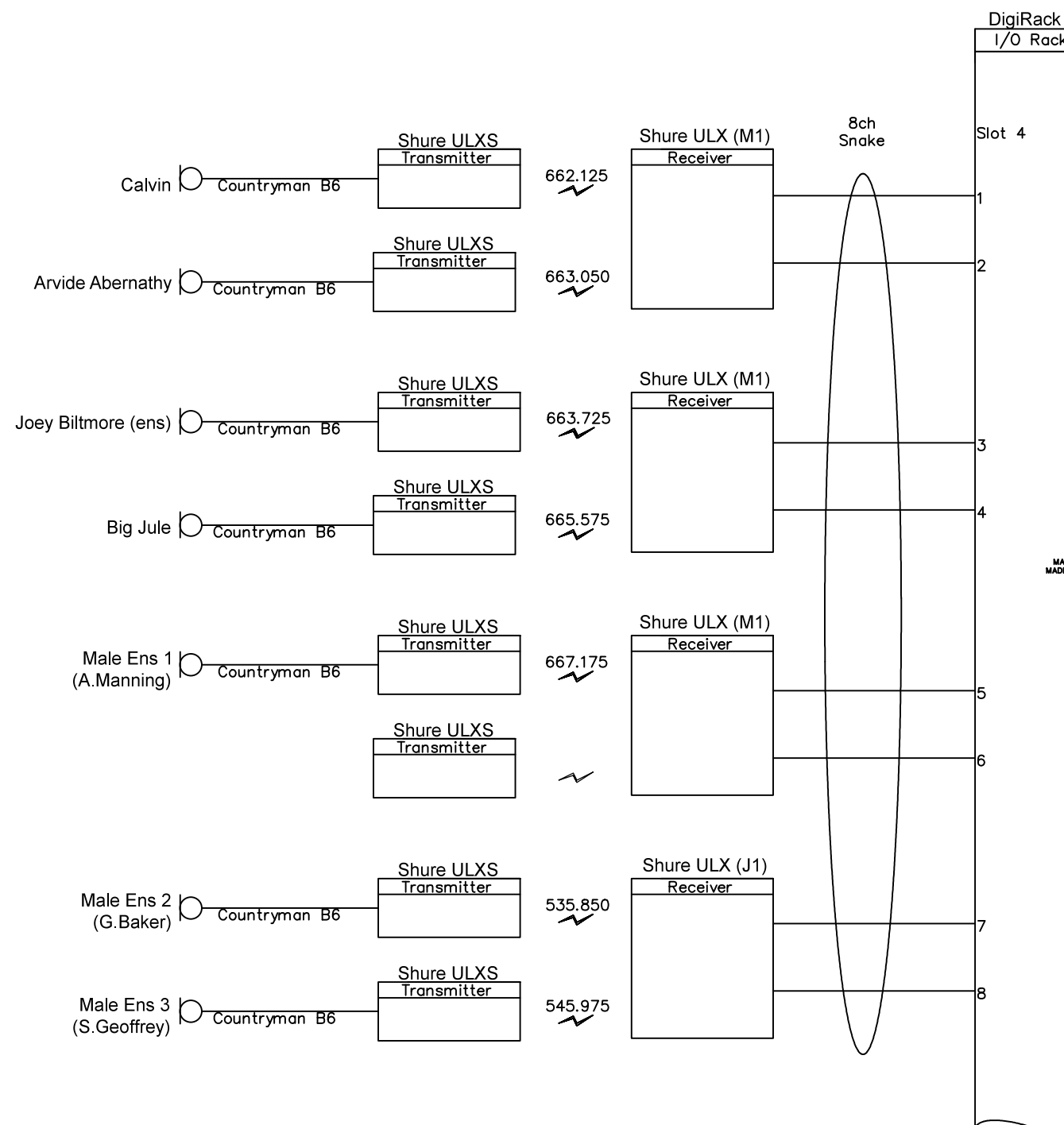
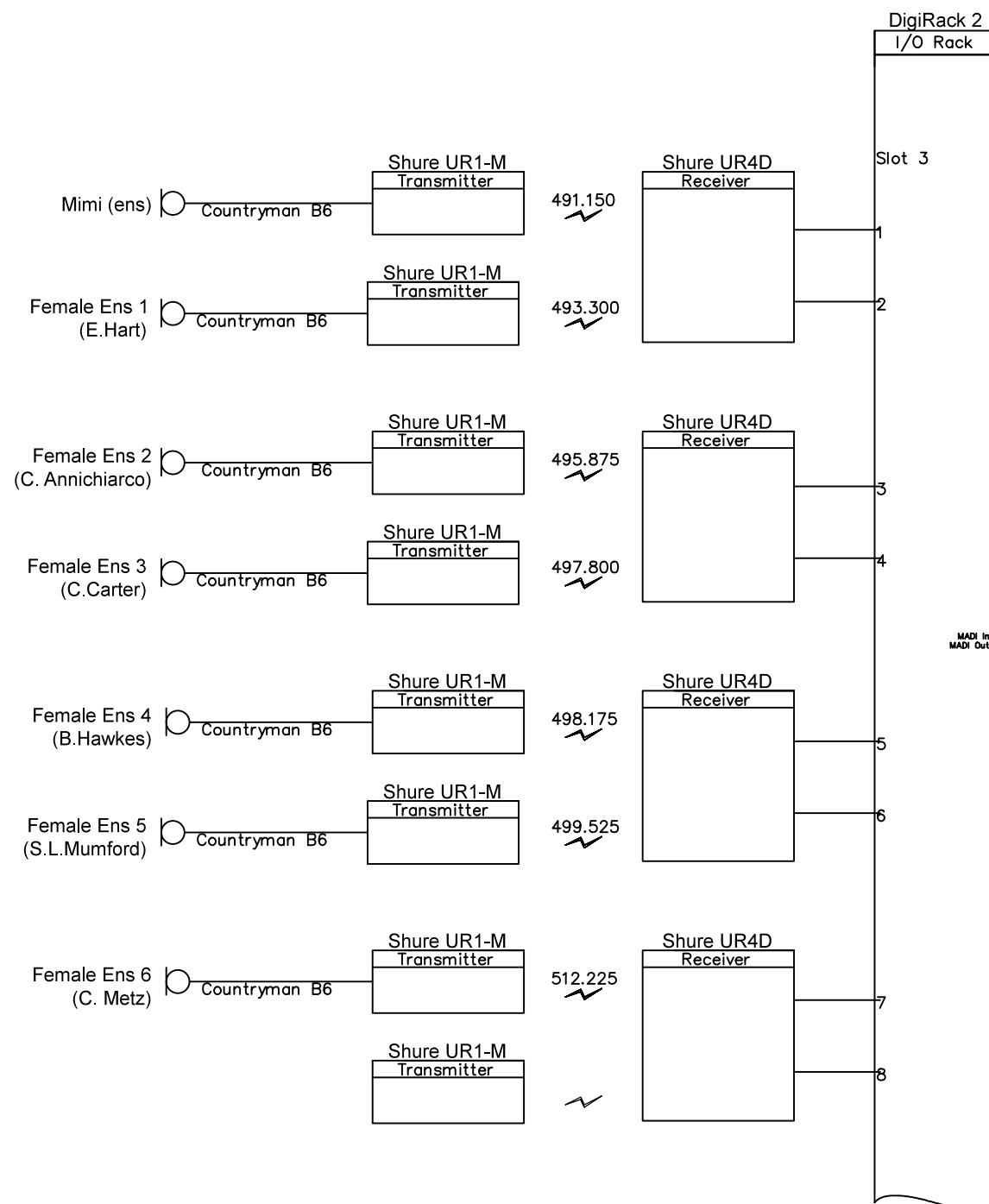

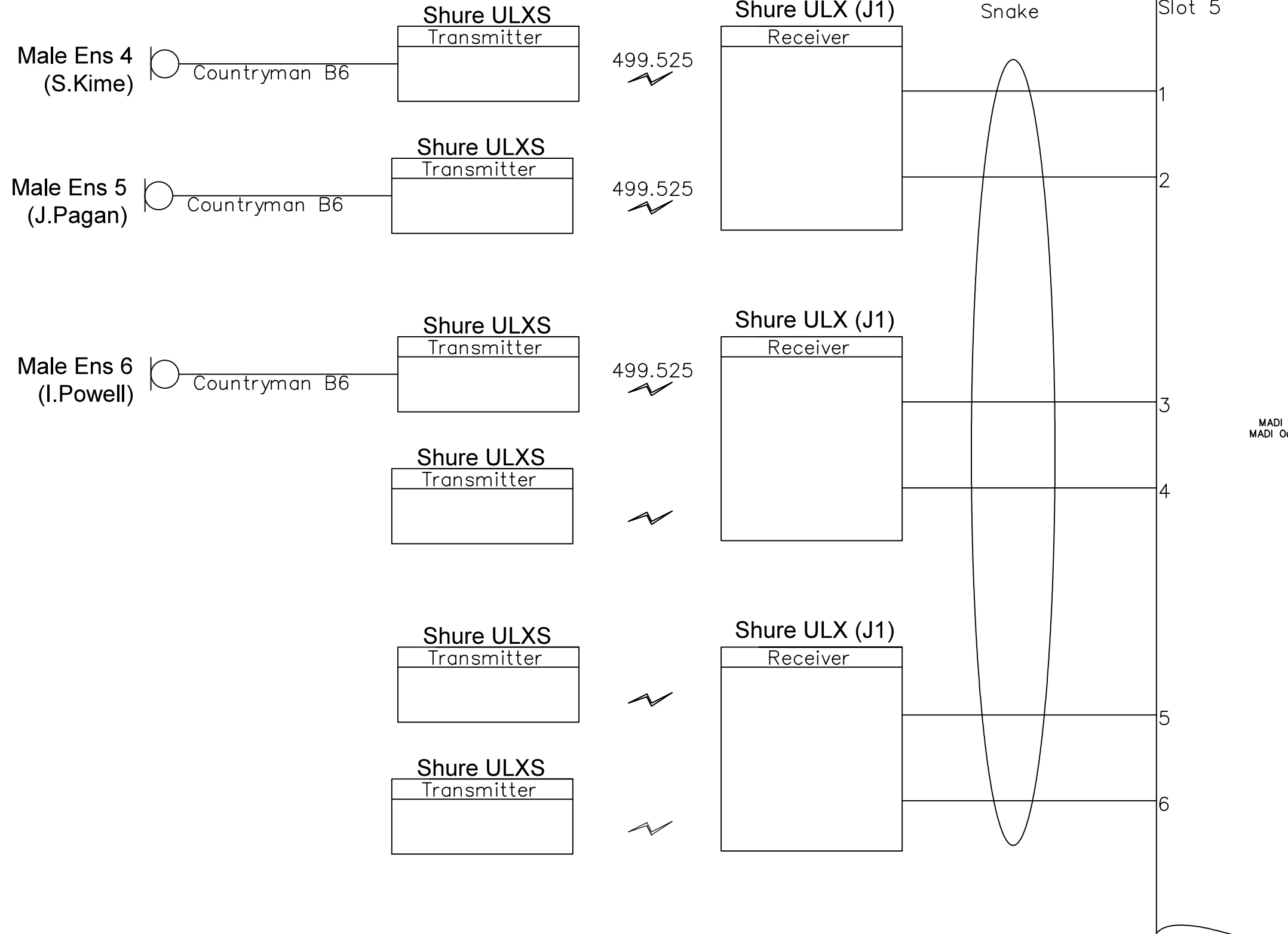

Tracy Cowit
Head Sound A1

Sound Designer
Drew Levy

Associate Sound Designer
Maria Wurttle
305.878.0893
wurttle.mf@artist.uncsa.edu

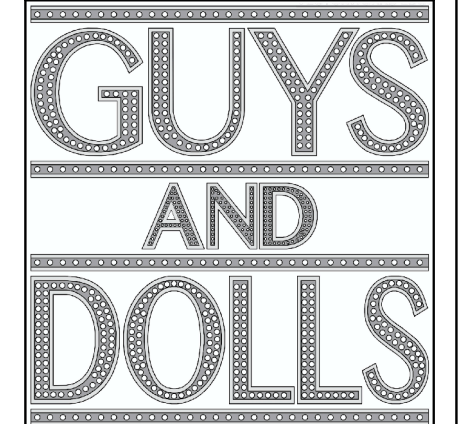

Venue
STEVENS CENTER

Producer
UNCSA

Director
GUS KAIKKONEN

Production Manager
DENNIS BOOTH

Scenic Designer
GARRET DAUB

Lighting Designer
AL CRAWFORD

Drawn By: TAC & GTS
File Name: Guys and Dolls v2015.dwg
Drawing Date: 04/25/15

Load-In Date 20 MARCH, 2015	Load-Out Date 19 APRIL, 2015
--------------------------------	---------------------------------

ONE LINE
DIGIRACK 2 - WIRELESS I/O

Plate
3.6

Tracy Cowit

Head Sound A1

Sound Designer
Drew Levy

Associate Sound Designer

Maria Wurttele

305.878.0893

wurttele.mf@artist.uncsa.edu

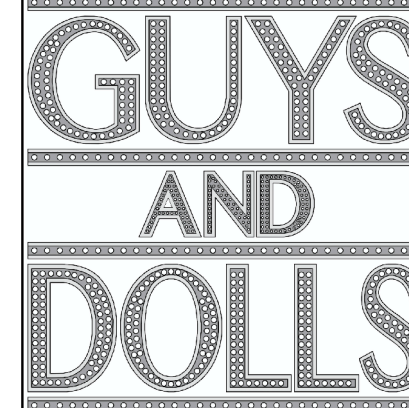

Venue

STEVENS CENTER

Producer

UNCSA

Director

GUS KAIKKONEN

Production Manager

DENNIS BOOTH

Scenic Designer

GARRET DAUB

Lighting Designer

AL CRAWFORD

Drawn By: TAC & GTS

File Name: Guys and Dolls v2015.dwg

Drawing Date: 04/25/15

Load-In Date

20 MARCH, 2015

Load-Out Date

19 APRIL, 2015

ONE LINE
DIGIRACK 2 I/O SIDECAR

Plate
3.7

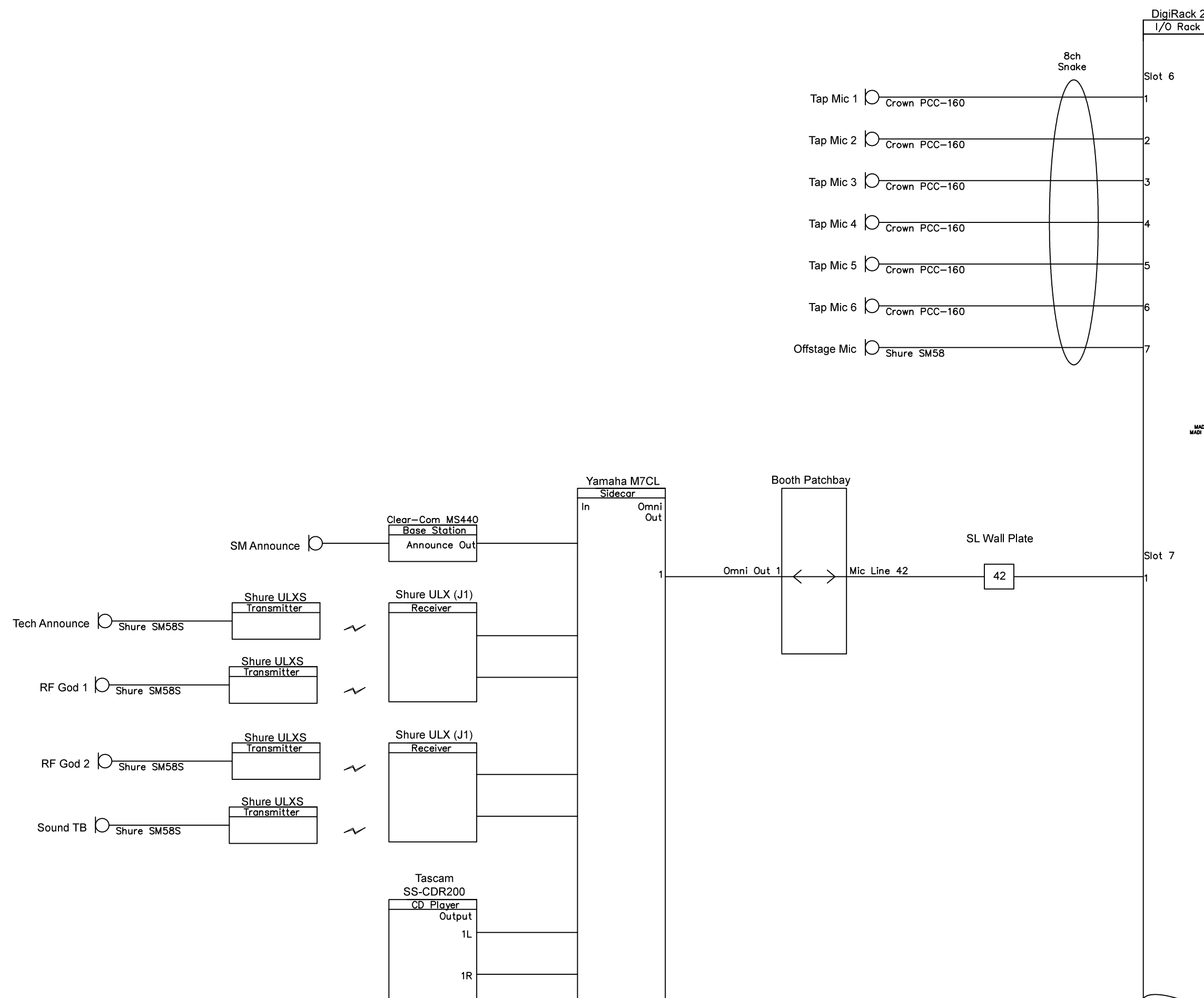

DiGiCo SD10T

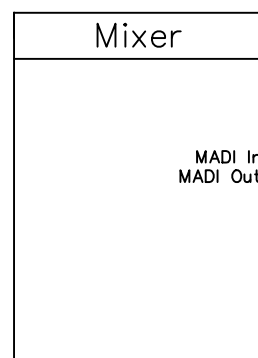

DigiRack 2

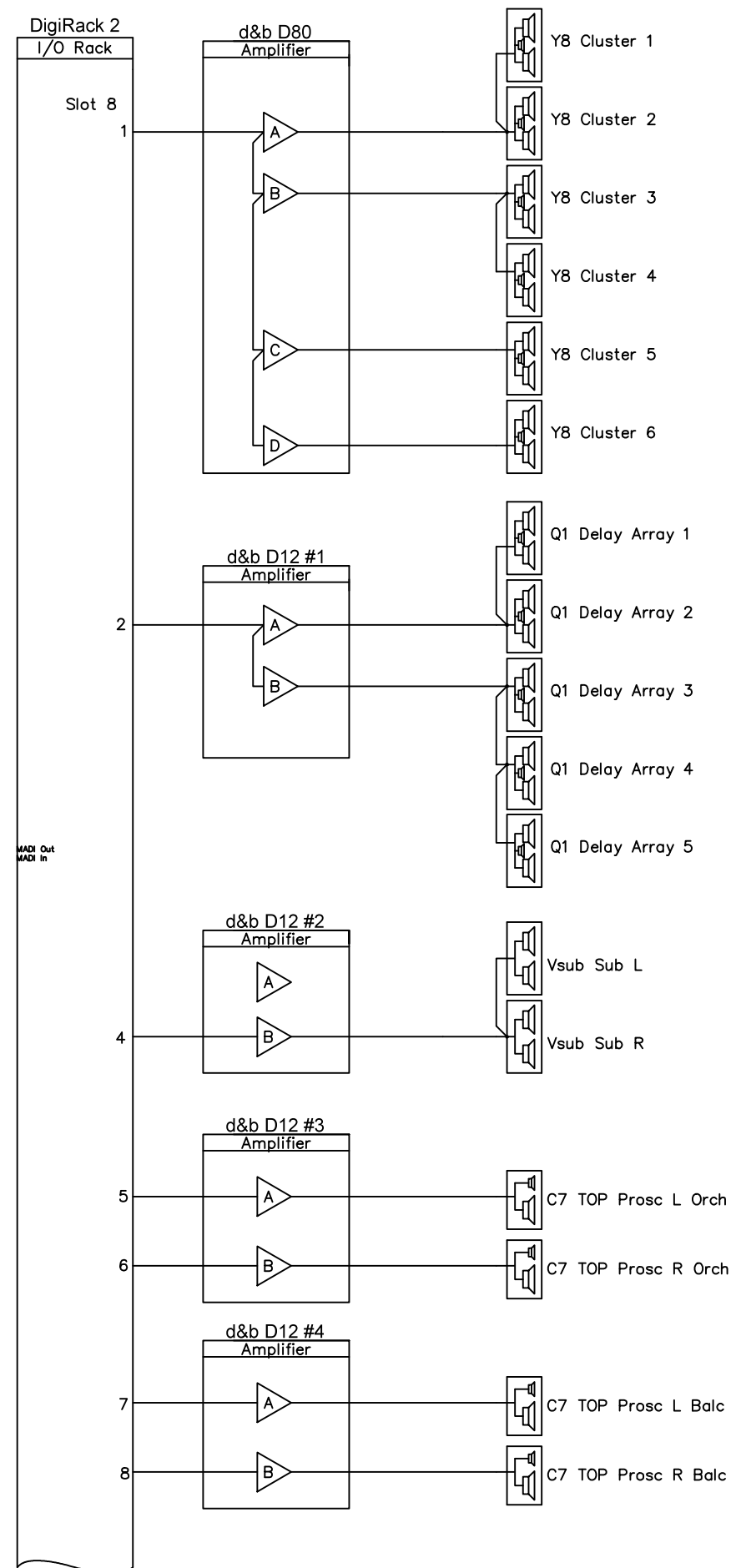
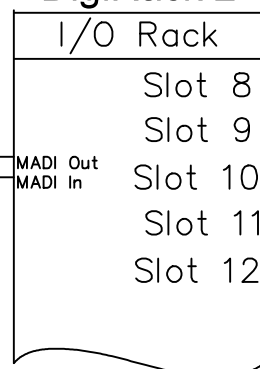

Tracy Cowit

Head Sound A1

Sound Designer
Drew Levy

Associate Sound Designer
Maria Wurtele

305.878.0893

wurtele.mf@artist.uncsa.edu

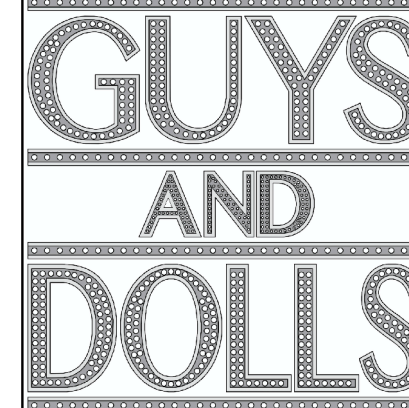

Venue

STEVENS CENTER

Producer

UNCSA

Director

GUS KAIKKONEN

Production Manager

DENNIS BOOTH

Scenic Designer

GARRET DAUB

Lighting Designer

AL CRAWFORD

Drawn By: TAC & GTS

File Name: Guys and Dolls v2015.dwg

Drawing Date: 04/25/15

Load-In Date

20 MARCH, 2015

Load-Out Date

19 APRIL, 2015

**ONE LINE
DIGIRACK 2 OUTPUTS**

Plate
3.8

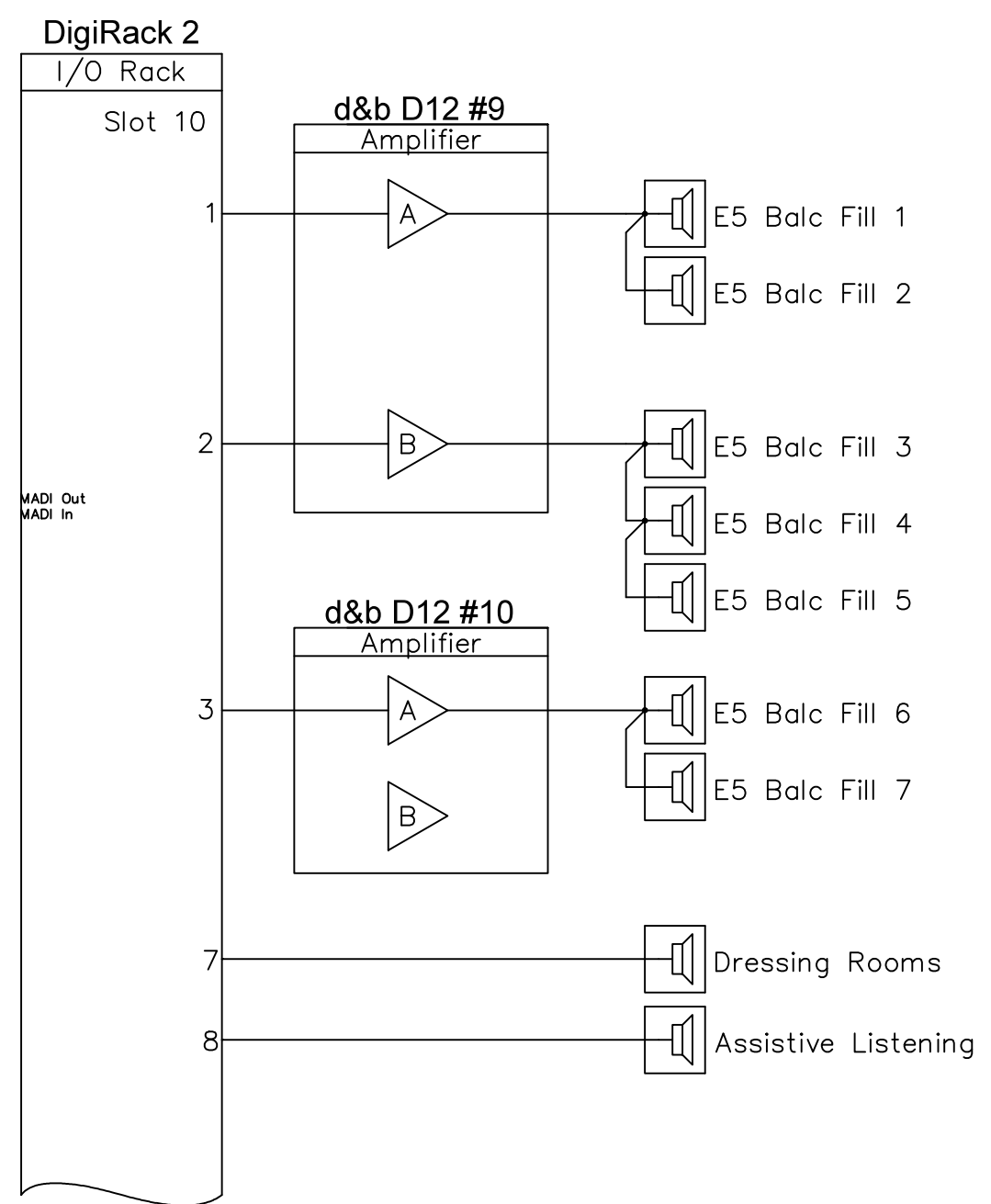
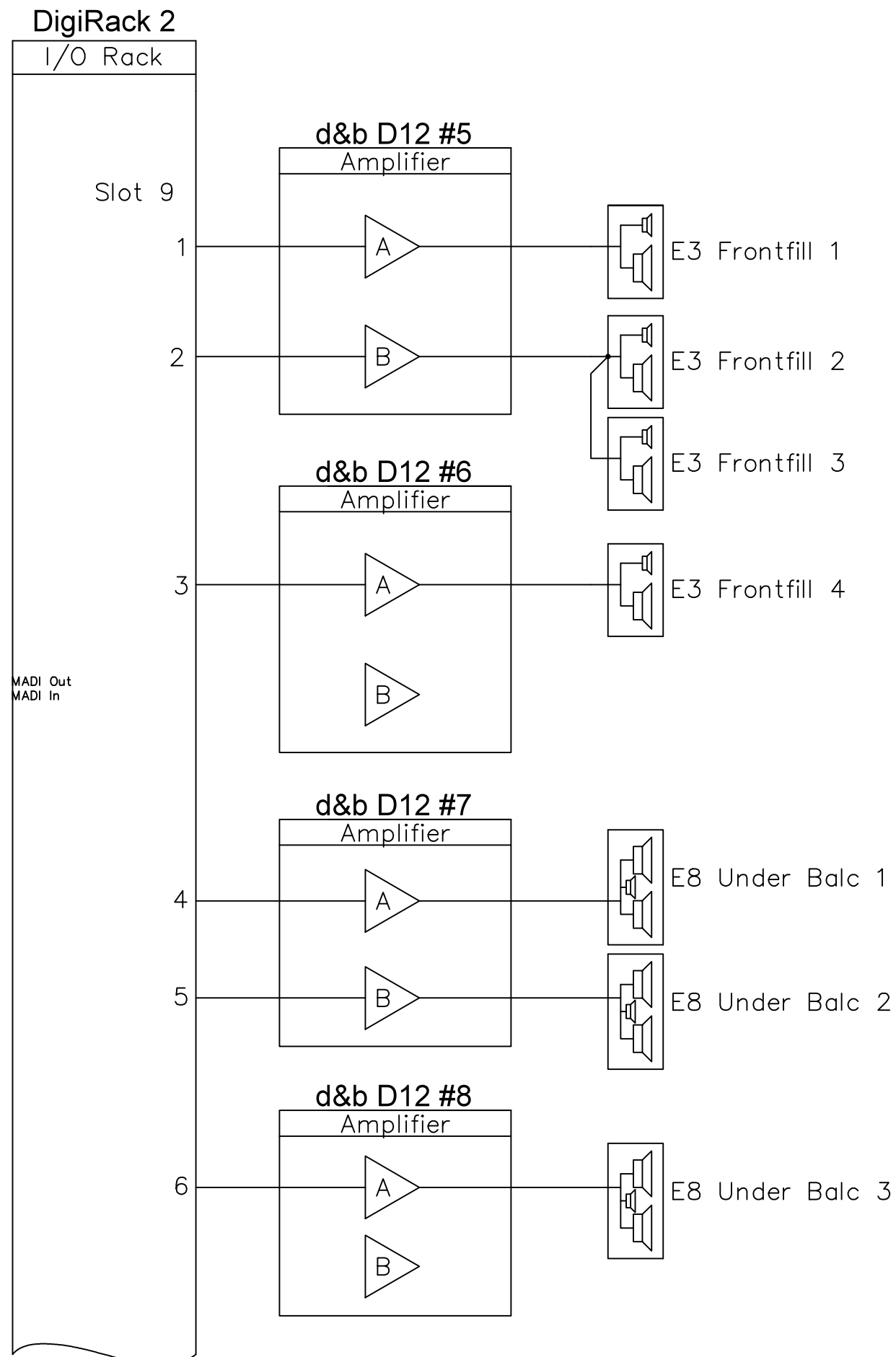

Tracy Cowit

Head Sound A1

Sound Designer

Drew Levy

Associate Sound Designer

Maria Wurttle

305.878.0893

wurttle.mf@artist.uncsa.edu

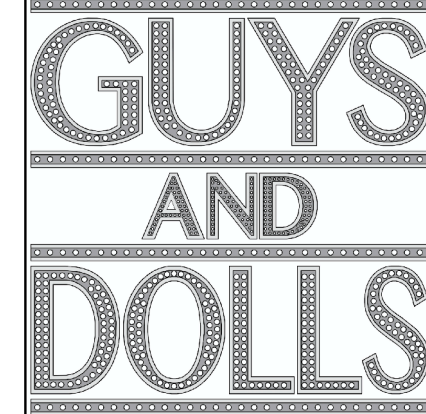

Venue

STEVENS CENTER

Producer

UNCSA

Director

GUS KAIKKONEN

Production Manager

DENNIS BOOTH

Scenic Designer

GARRET DAUB

Lighting Designer

AL CRAWFORD

Drawn By: TAC & GTS

File Name: Guys and Dolls v2015.dwg

Drawing Date: 04/25/15

Load-In Date

20 MARCH, 2015

Load-Out Date

19 APRIL, 2015

**ONE LINE
DIGIRACK 2 OUTPUTS**

Plate
3.9

DIGIRACK 2

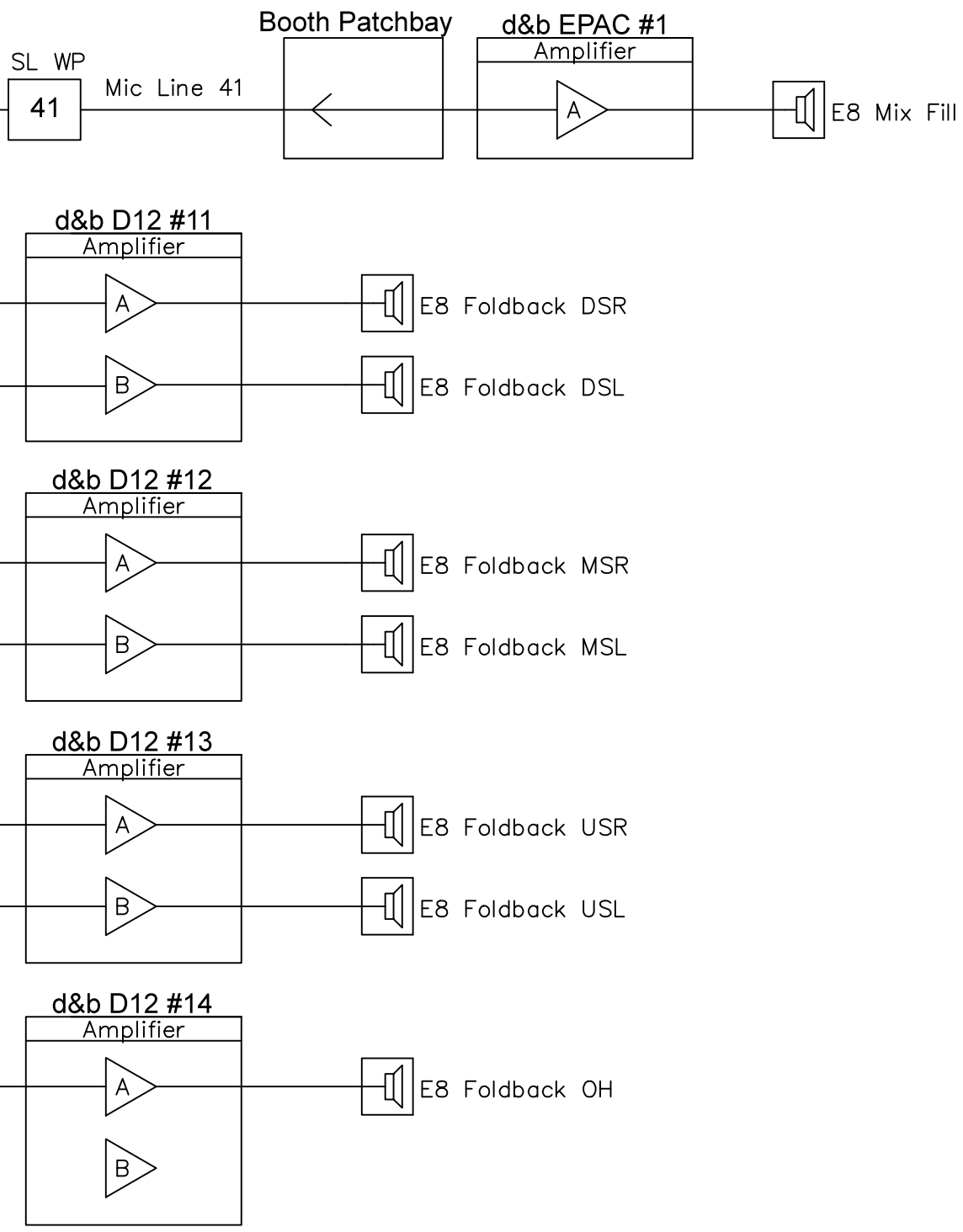
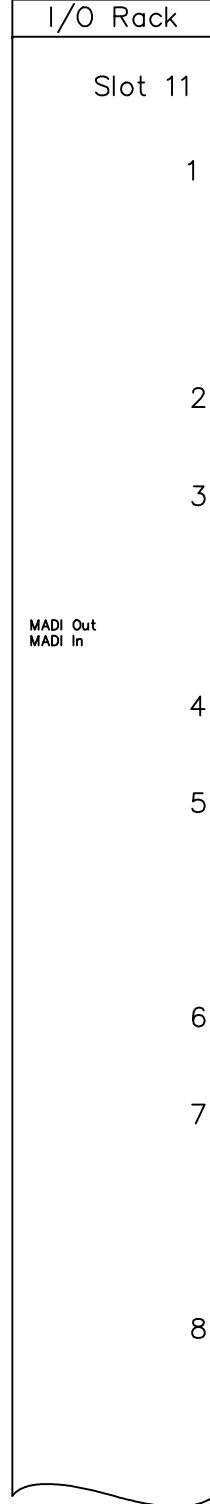

DIGIRACK 2

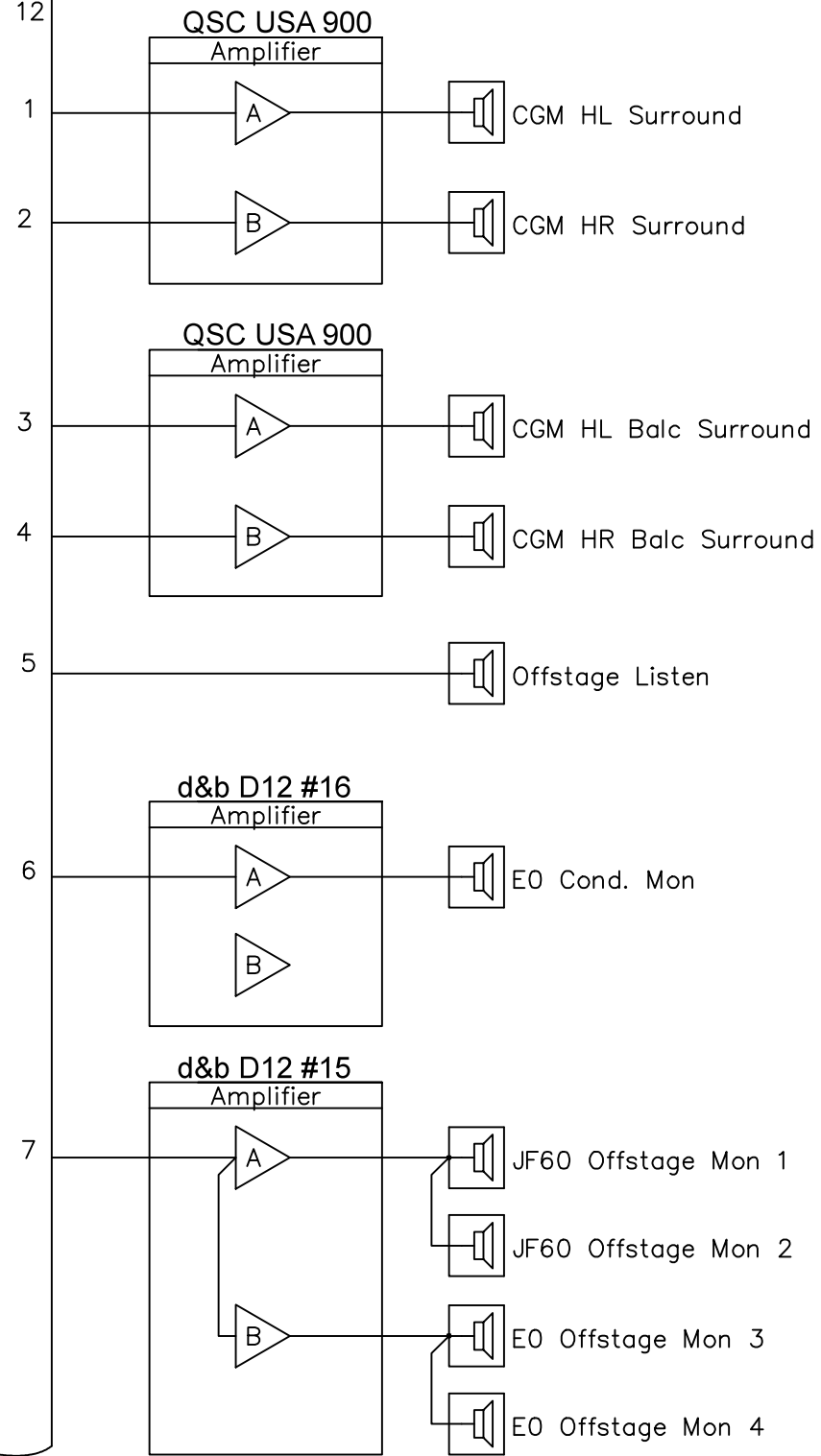
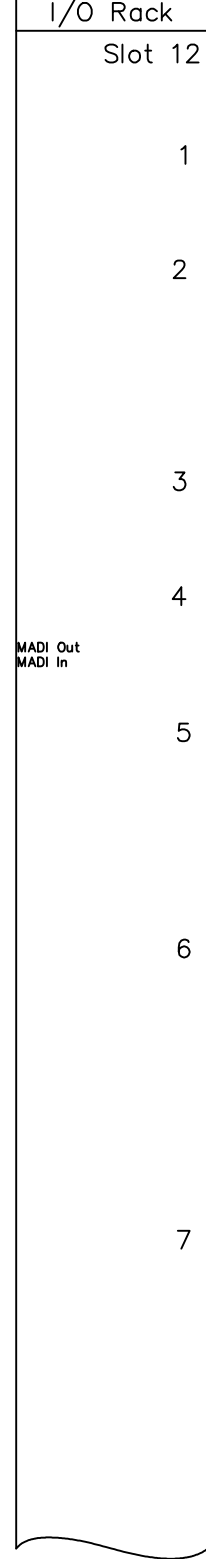

Tracy Cowit

Head Sound A1

Sound Designer

Drew Levy

Associate Sound Designer

Maria Wurttle

305.878.0893

wurttle.mf@artist.uncsa.edu

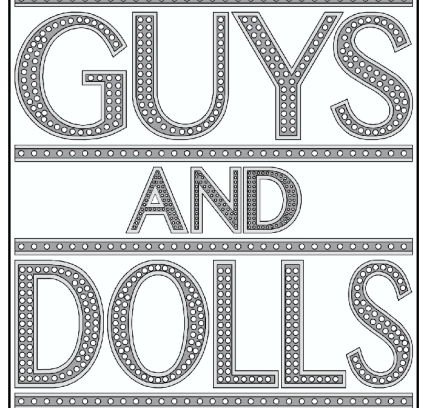

Venue

STEVENS CENTER

Producer

UNCSA

Director

GUS KAIKKONEN

Production Manager

DENNIS BOOTH

Scenic Designer

GARRET DAUB

Lighting Designer

AL CRAWFORD

Drawn By: TAC & GTS

File Name: Guys and Dolls v2015.dwg

Drawing Date: 04/25/15

Load-In Date

20 MARCH, 2015

Load-Out Date

19 APRIL, 2015

**ONE LINE
DIGIRACK 2 OUTPUTS**

Plate
3.10

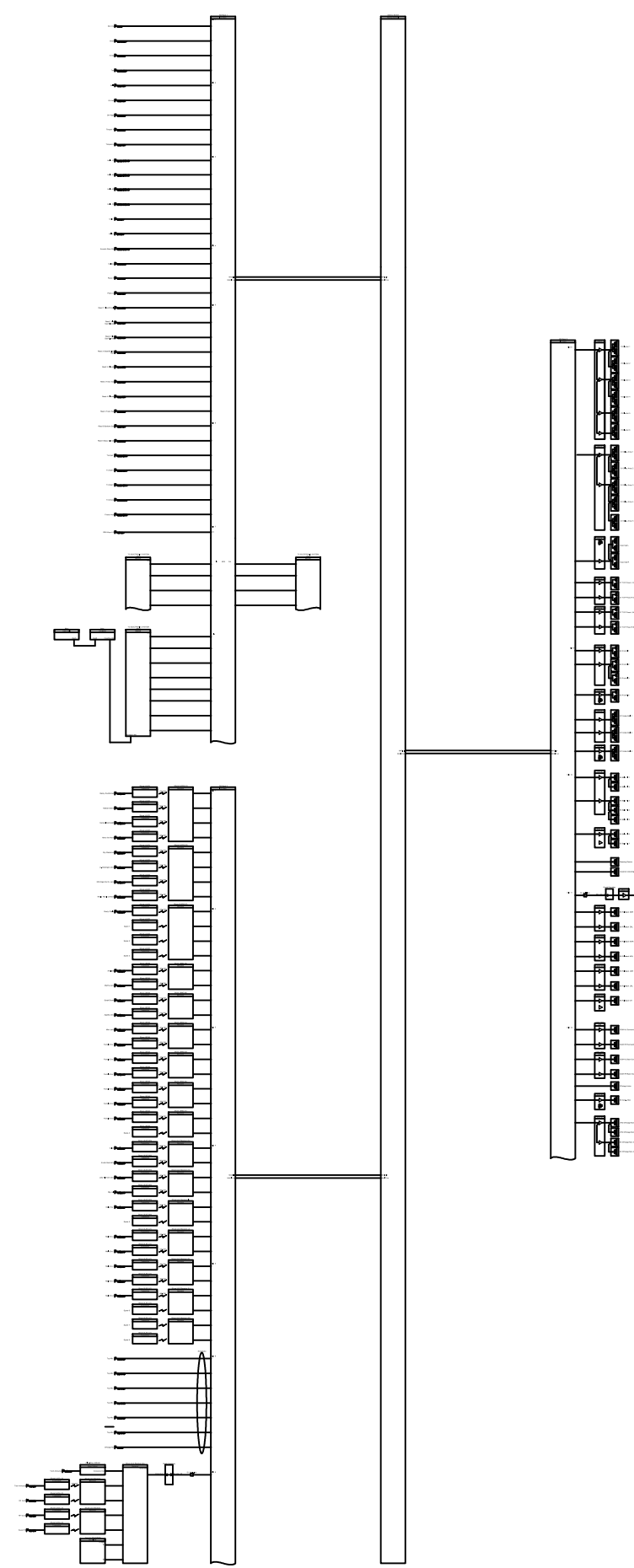

Tracy Cowit

Head Sound A1

Sound Designer
Drew Levy

Associate Sound Designer
Maria Wurttele

305.878.0893

wurttele.mf@artist.uncsa.edu

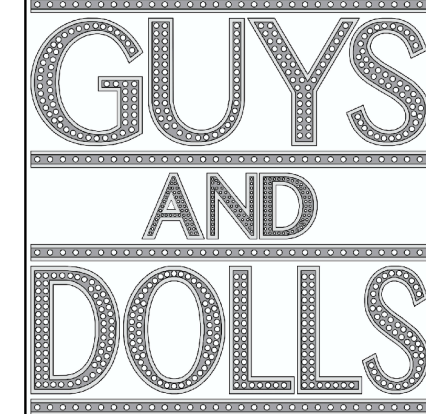

Venue

STEVENS CENTER

Producer

UNCSA

Director

GUS KAIKKONEN

Production Manager

DENNIS BOOTH

Scenic Designer

GARRET DAUB

Lighting Designer

AL CRAWFORD

Drawn By: TAC & GTS

File Name: Guys and Dolls v2015.dwg

Drawing Date: 04/25/15

Load-In Date

20 MARCH, 2015

Load-Out Date

19 APRIL, 2015

**ONE LINE
FULL LAYOUT**

Plate
3.11

Tracy Cowit

Head Sound A1

Sound Designer

Drew Levy

Associate Sound Designer

Maria Wurttele

305.878.0893

wurttele.mf@artist.uncsa.edu

GUYS AND DOLLS

Venue

STEVENS CENTER

Producer

UNCSA

Director

GUS KAIKKONEN

Production Manager

DENNIS BOOTH

Scenic Designer

GARRET DAUB

Lighting Designer

AL CRAWFORD

Drawn By: TAC

File Name: Guys and Dolls v2015.dwg

Drawing Date: 04/25/15

Load-In Date

20 MARCH, 2015

Load-Out Date

19 APRIL, 2015

**ORCH PIT
LAYOUT**

Plate
4.1

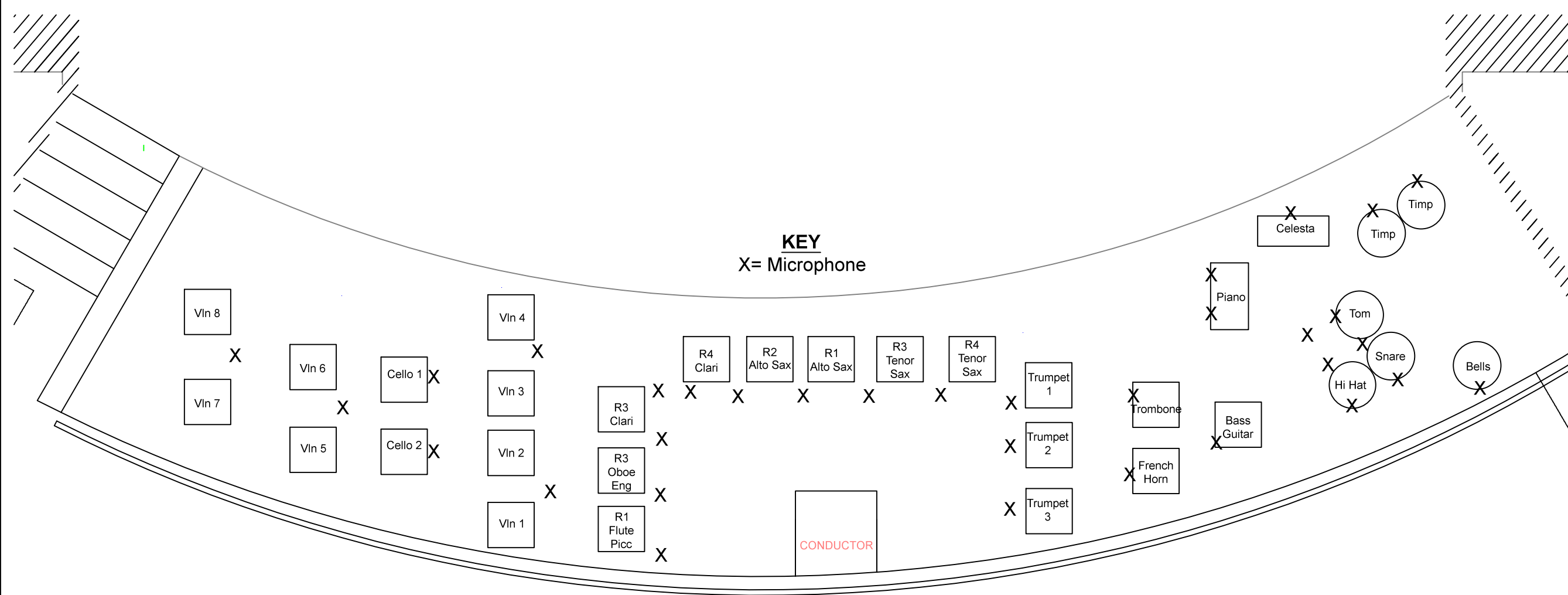

KEY
X= Microphone

CONDUCTOR

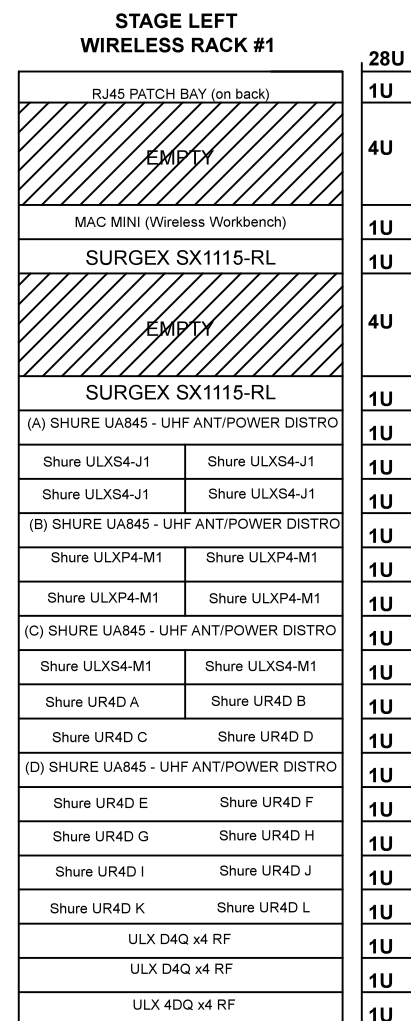
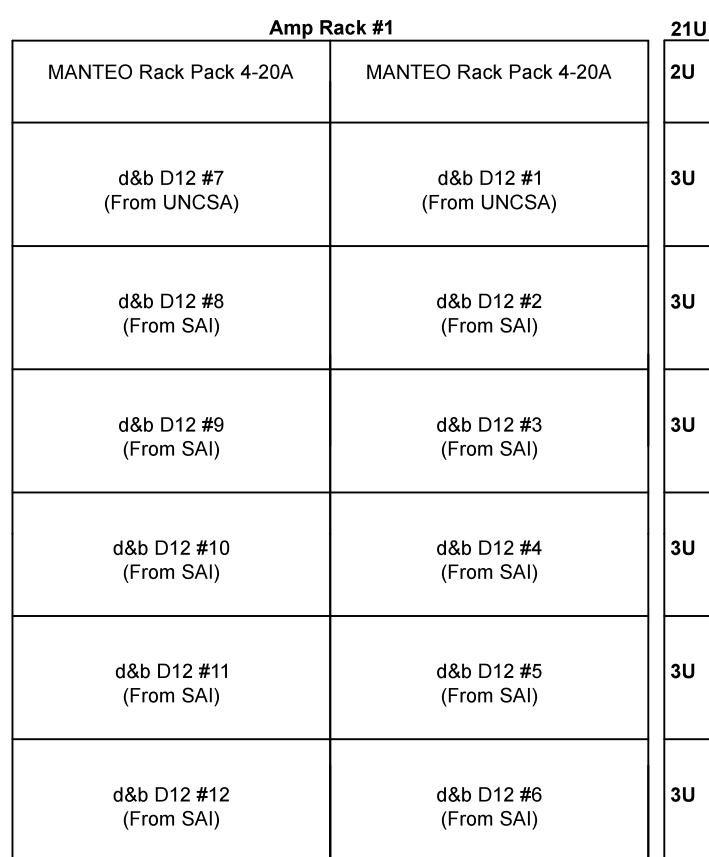
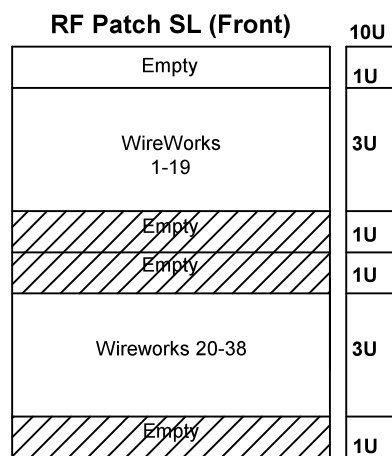
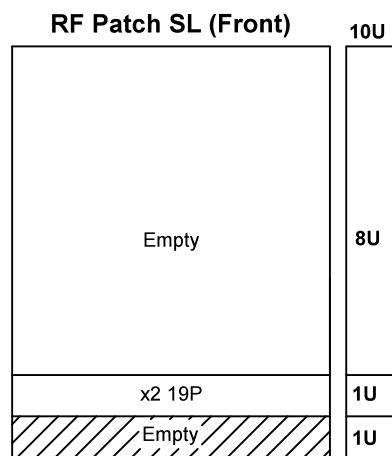
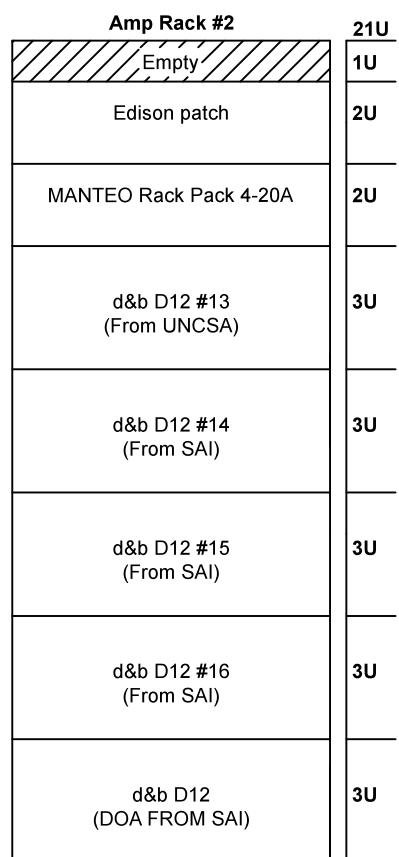
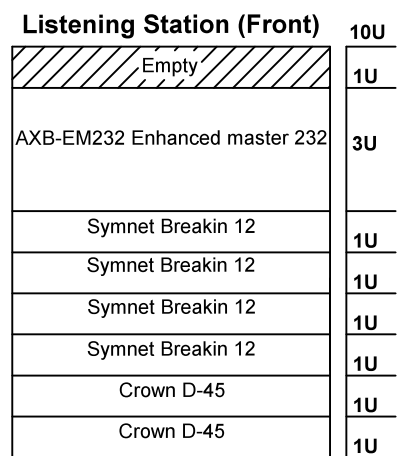
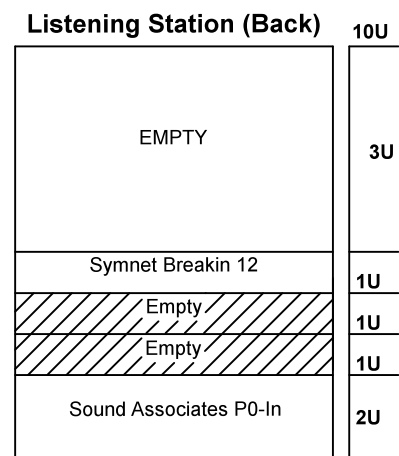
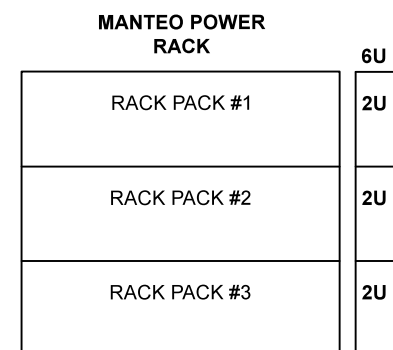
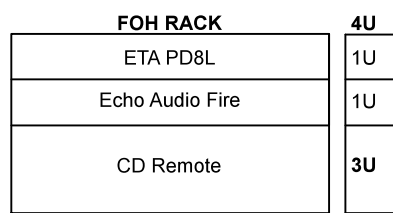
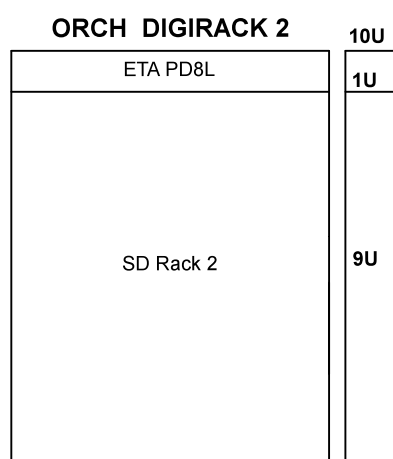
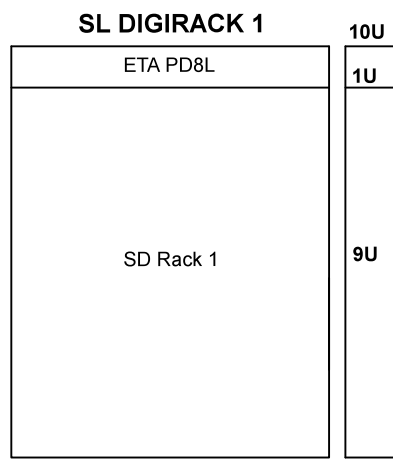

Tracy Cowit

Head Sound A1

Sound Designer
Drew Levy

Associate Sound Designer

Maria Wurtele

305.878.0893

wurtele.mf@artist.uncsa.edu

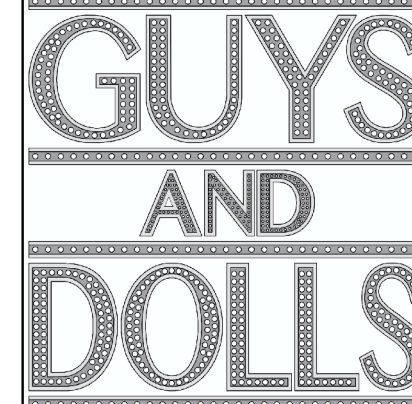

Venue

STEVENS CENTER

Producer

UNCSA

Director

GUS KAIKKONEN

Production Manager

DENNIS BOOTH

Scenic Designer

GARRET DAUB

Lighting Designer

AL CRAWFORD

Drawn By: TAC

File Name: Guys and Dolls v2015.dwg

Drawing Date: 04/25/15

Load-In Date

20 MARCH, 2015

Load-Out Date

19 APRIL, 2015

RACK DIAGRAM

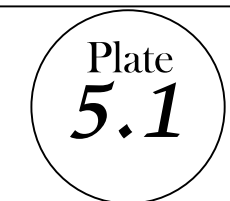

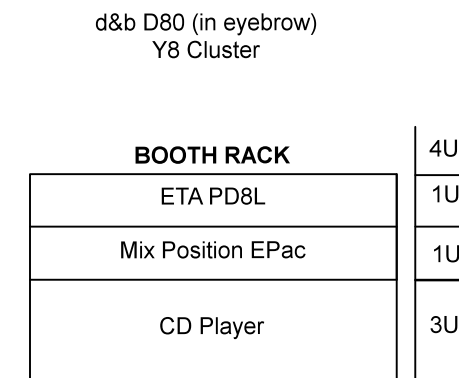
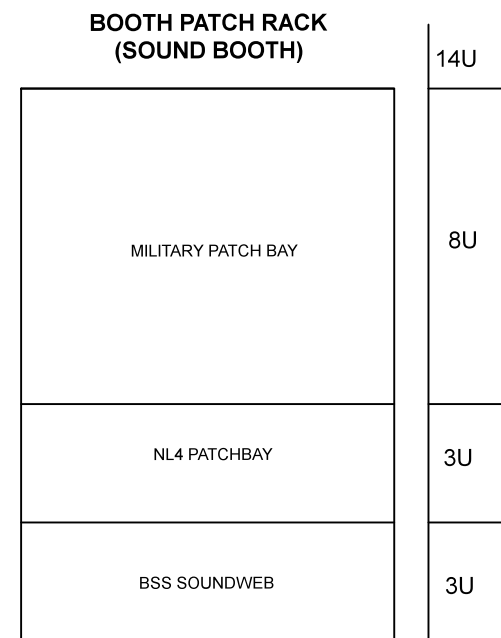
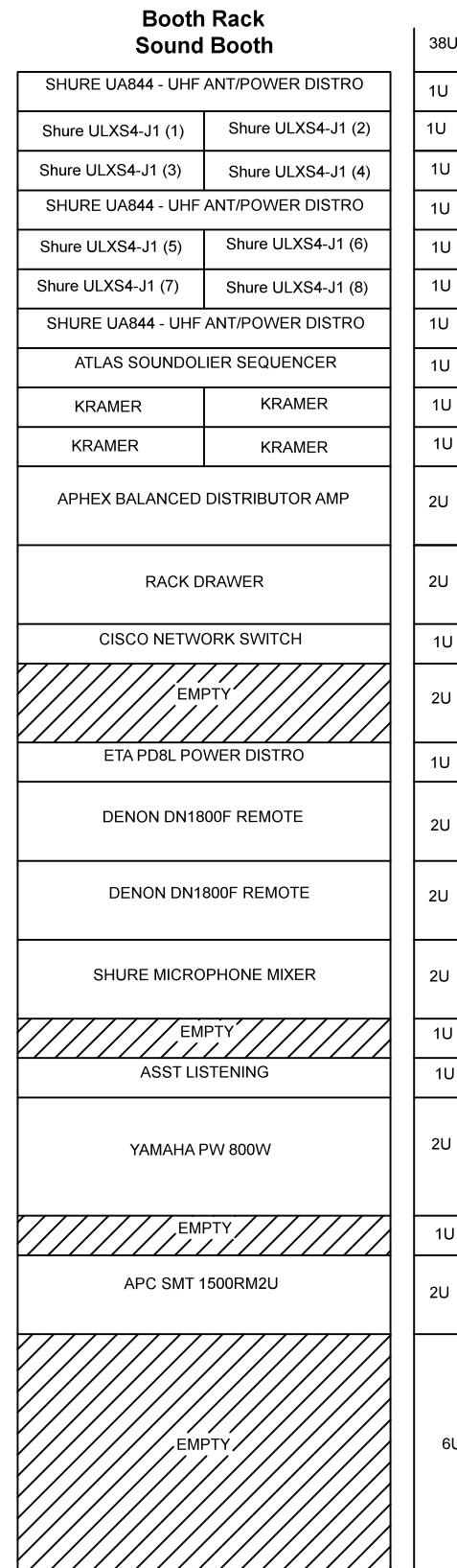
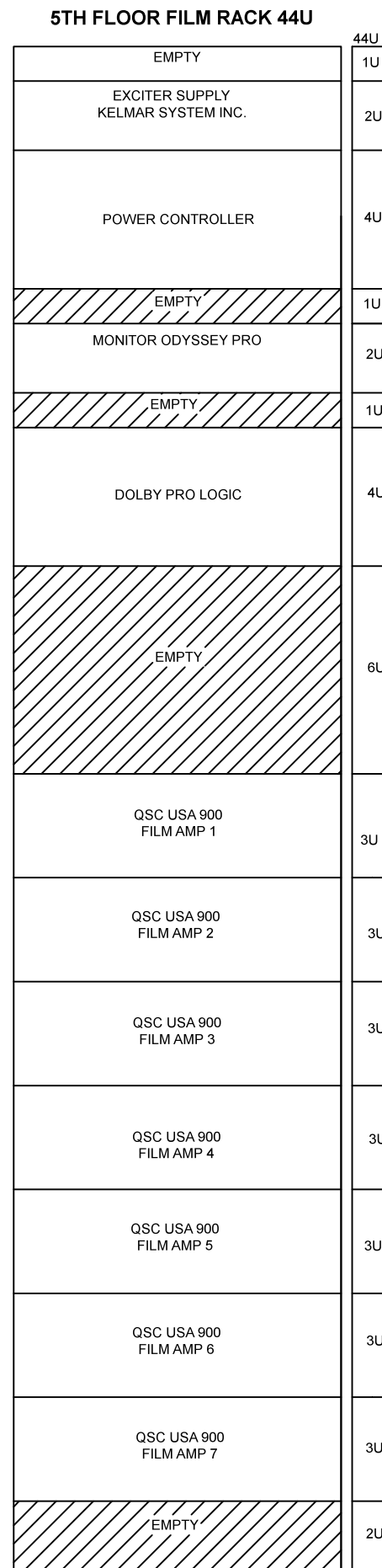
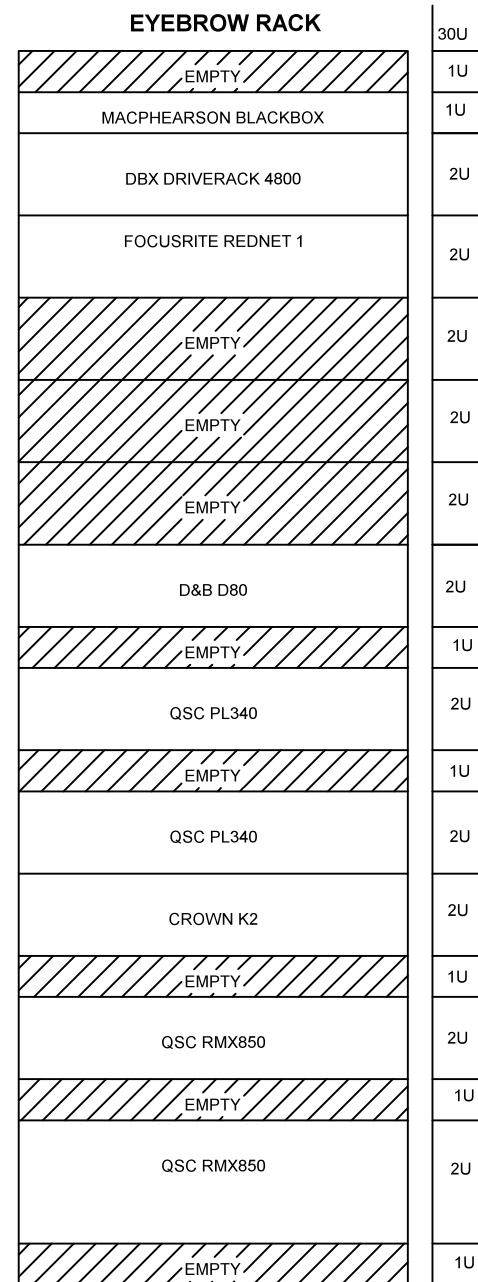

Tracy Cowit
Head Sound A1

Sound Designer
Drew Levy

Associate Sound Designer
Maria Wurttele
305.878.0893
wurttele.mf@artist.uncsa.edu

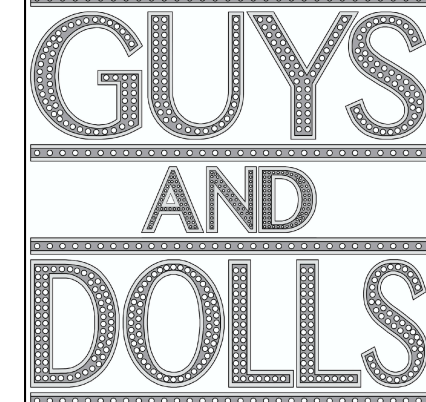

Venue
STEVENS CENTER

Producer
UNCSA

Director
GUS KAIKKONEN

Production Manager
DENNIS BOOTH

Scenic Designer
GARRET DAUB

Lighting Designer
AL CRAWFORD

Drawn By: TAC
File Name: Guys and Dolls v2015.dwg
Drawing Date: 04/25/15

Load-In Date
20 MARCH, 2015

Load-Out Date
19 APRIL, 2015

**RACK DIAGRAM
HOUSE RACKS**

Plate
5.2

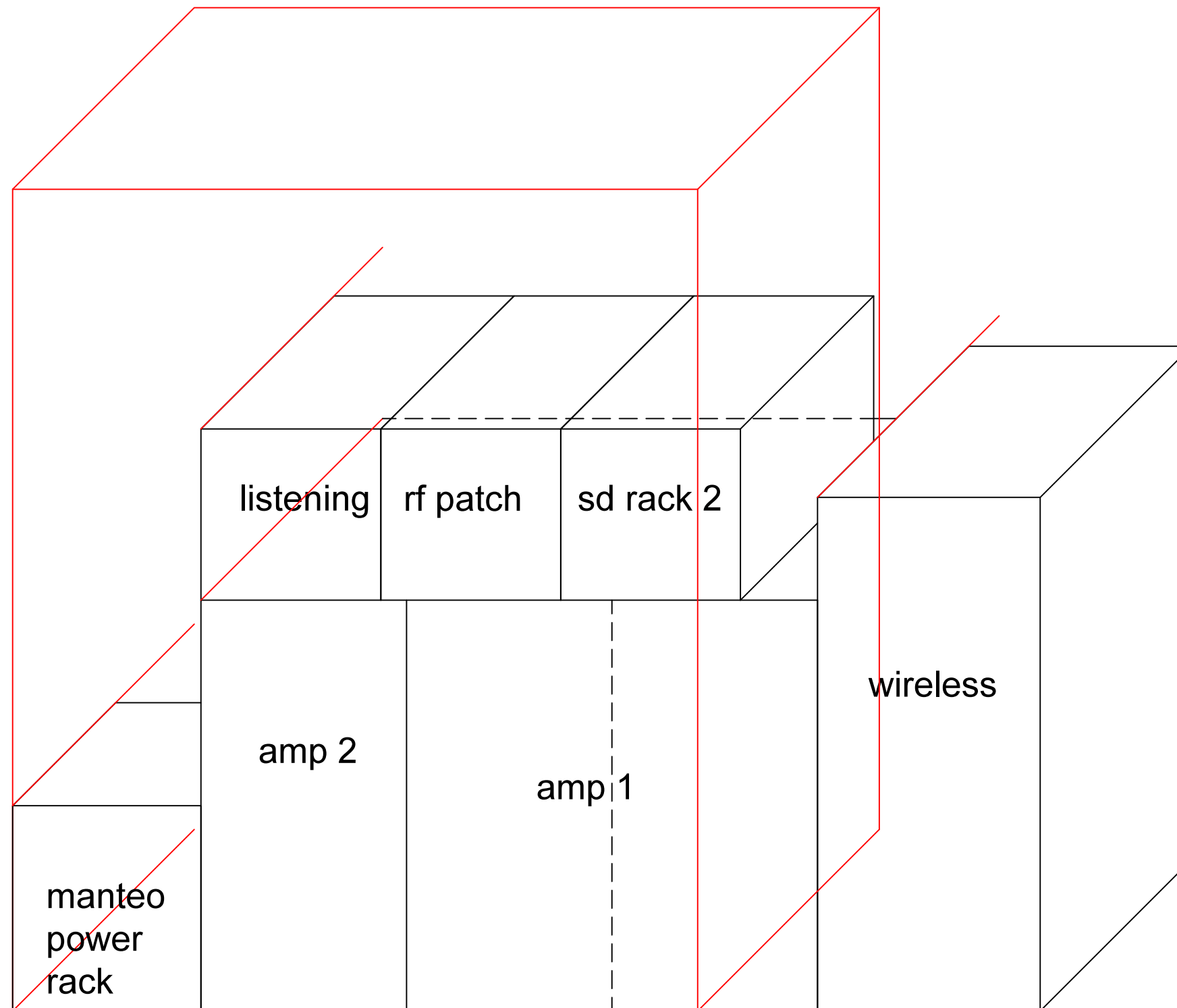

3'-4" over width

Tracy Cowit

Head Sound A1

Sound Designer
Drew Levy

Associate Sound Designer
Maria Wurttele

305.878.0893
wurttele.mf@artist.uncsa.edu

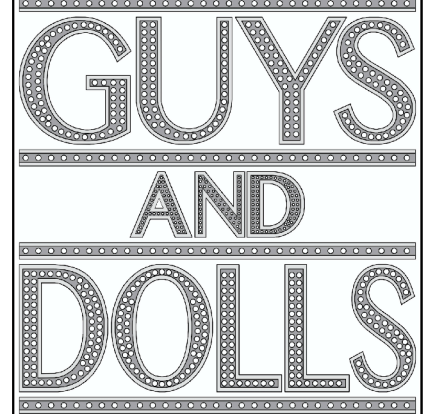

Venue
STEVENS CENTER

Producer
UNCSA

Director
GUS KAIKKONEN

Production Manager
DENNIS BOOTH

Scenic Designer
GARRET DAUB

Lighting Designer
AL CRAWFORD

Drawn By: TAC & GTS
File Name: Guys and Dolls v2015.dwg
Drawing Date: 04/25/15

Load-In Date 20 MARCH, 2015	Load-Out Date 19 APRIL, 2015
--------------------------------	---------------------------------

**RACK ARRANGEMENT
OPTION #1**

Plate
5.3

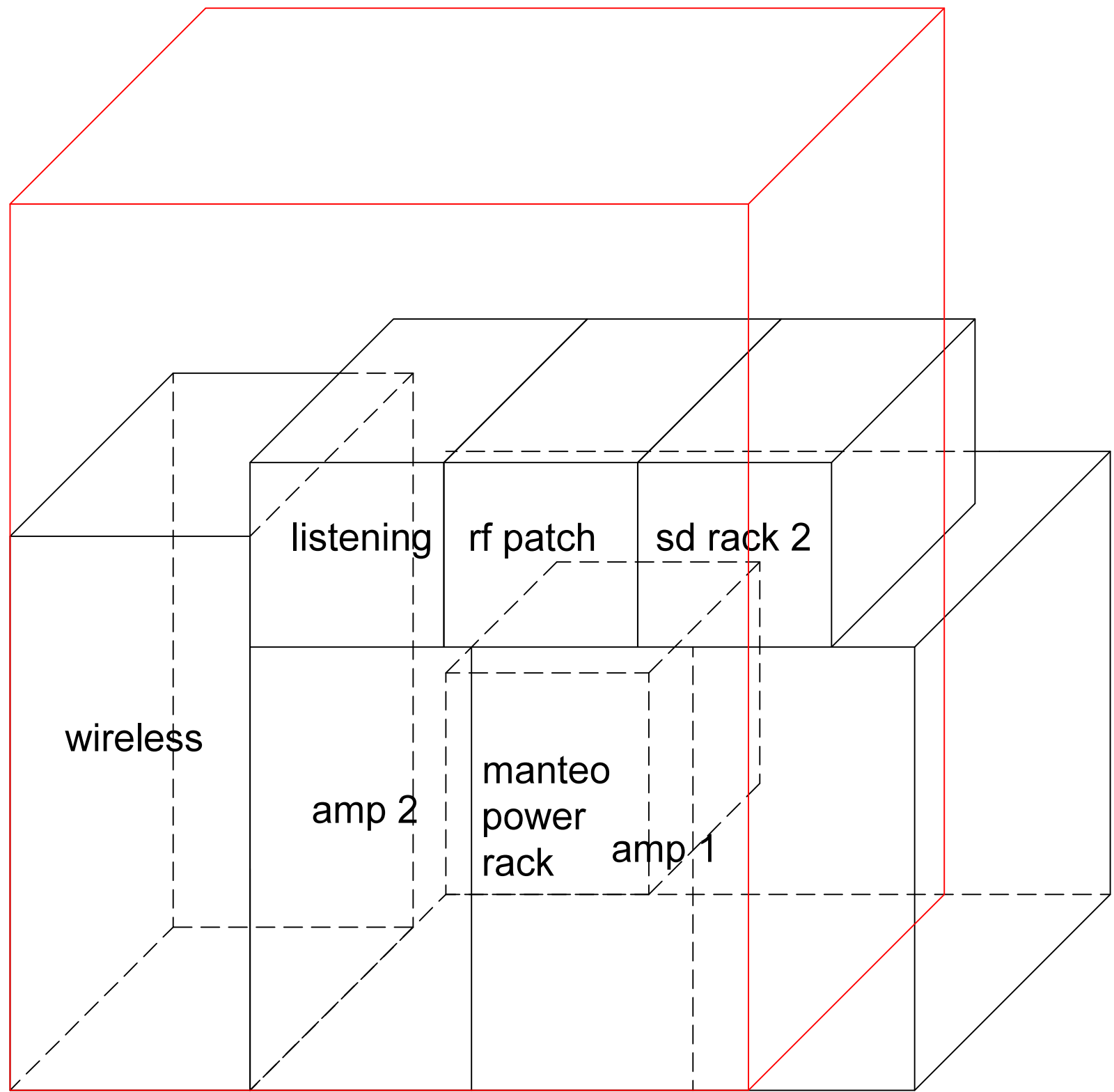

manteo power 1'-6" too wide
 woud be under 1'-5" too deep
 orchestra shell

Tracy Cowit
 Head Sound A1

Sound Designer
 Drew Levy

Associate Sound Designer
 Maria Wurttele
 305.878.0893
 wurttele.mf@artist.uncsa.edu

**GUYS
 AND
 DOLLS**

Venue
 STEVENS CENTER

Producer
 UNCSA

Director
 GUS KAIKKONEN

Production Manager
 DENNIS BOOTH

Scenic Designer
 GARRET DAUB

Lighting Designer
 AL CRAWFORD

Drawn By: TAC & GTS
 File Name: Guys and Dolls v2015.dwg
 Drawing Date: 04/25/15

Load-In Date 20 MARCH, 2015	Load-Out Date 19 APRIL, 2015
--------------------------------	---------------------------------

**RACK ARRANGEMENT
 OPTION #2**

Plate
5.4

Tracy Cowit

Head Sound A1

Sound Designer

Drew Levy

Associate Sound Designer

Maria Wurttele

305.878.0893

wurttele.mf@artist.uncsa.edu

GUYS AND DOLLS

Venue

STEVENS CENTER

Producer

UNCSA

Director

GUS KAIKKONEN

Production Manager

DENNIS BOOTH

Scenic Designer

GARRET DAUB

Lighting Designer

AL CRAWFORD

Drawn By: TAC & GTS

File Name: Guys and Dolls v2015.dwg

Drawing Date: 04/25/15

Load-In Date

20 MARCH, 2015

Load-Out Date

19 APRIL, 2015

RACK ARRANGEMENT

FINAL

Plate
5.5

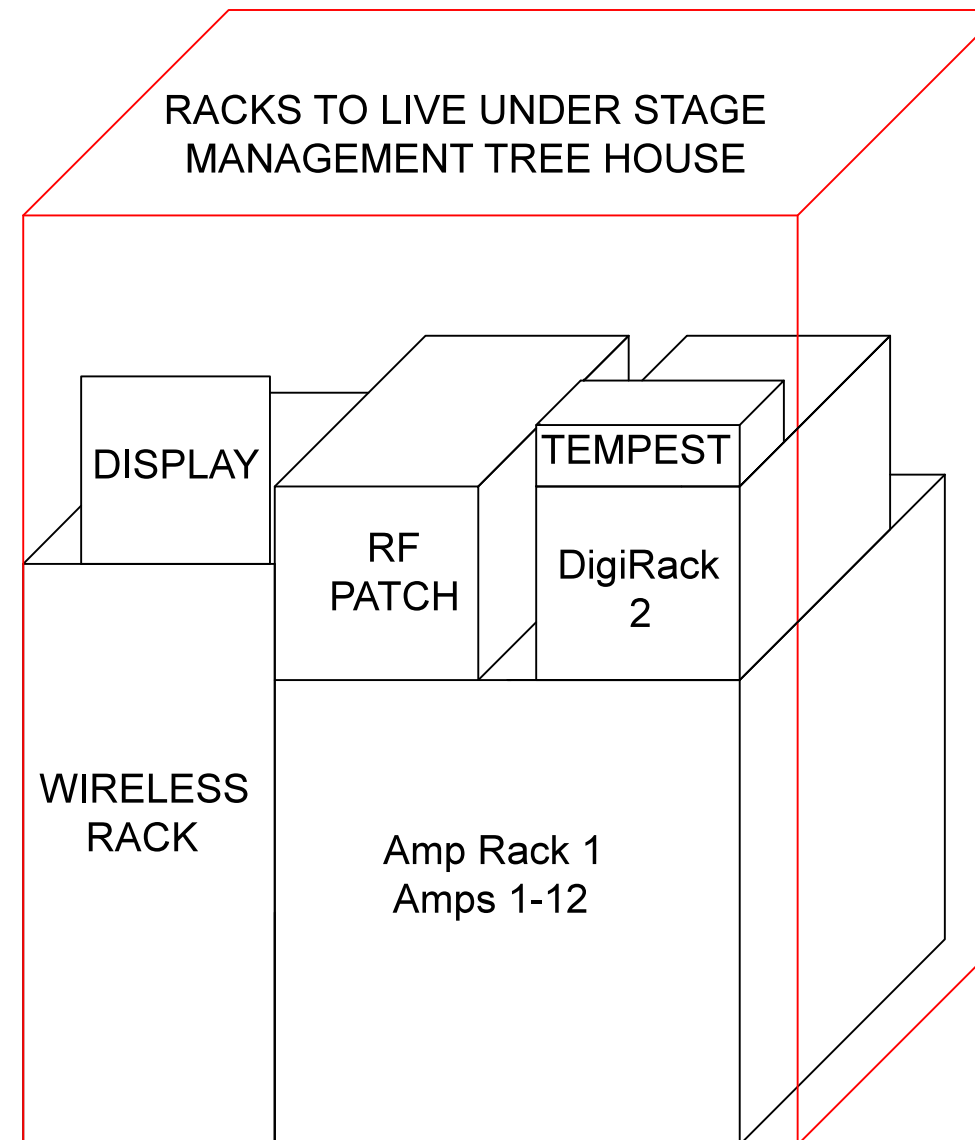
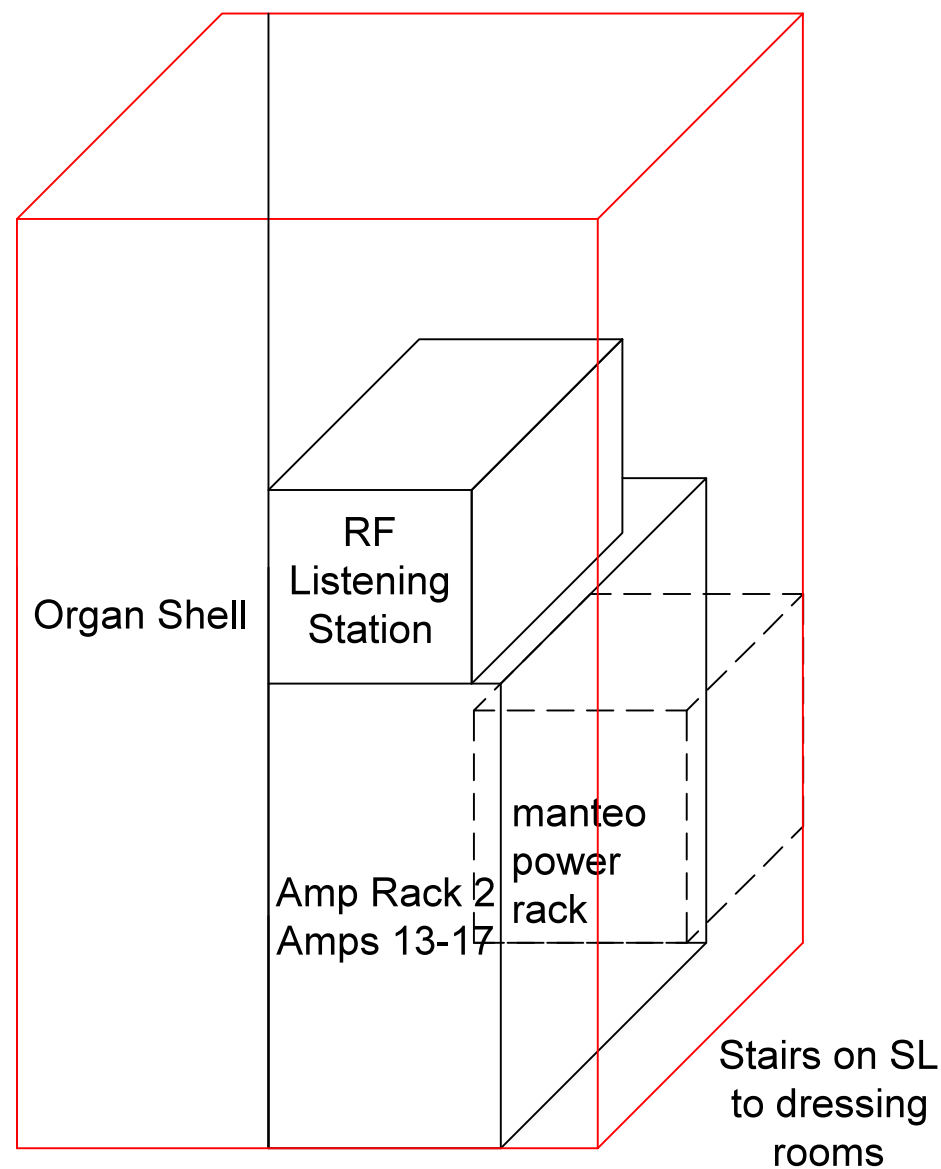

Tracy Cowit

Head Sound A1

Sound Designer
Drew Levy

Associate Sound Designer
Maria Wurttele

305.878.0893
wurttele.mf@artist.uncsa.edu

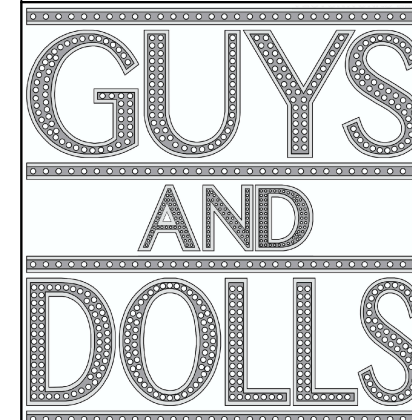

Venue

STEVENS CENTER

Producer

UNCSA

Director

GUS KAIKKONEN

Production Manager

DENNIS BOOTH

Scenic Designer

GARRET DAUB

Lighting Designer

AL CRAWFORD

Drawn By: TAC/ Updates By: TAC & GTS

File Name: Guys and Dolls v2015.dwg

Drawing Date: 04/25/15

Load-In Date

20 MARCH, 2015

Load-Out Date

19 APRIL, 2015

COM MATRIX

Plate
6.1

TECH MODE!

		COM PORT/ POSITION																										
Com Channel		CC1-CC8 Stage Manager	Deck Electric@ SL (Elizabeth)	Deck Electrician SR (Abby May)	Lighting Designer (AI)	AST. Lighting (Manny)	Lighting Operator Booth	LX Programmer 1 (Eric Dwyer)	LX Programmer 2 (Liam Lewis-Marlow)	Spot Op #1	Spot Op #2	Fly 1 @SR (Jenny Tvorogova)	Fly 2 @SR (Colin Surra)	Fly 3 @SR (Zach Feivou)	SR Deck Automation (Sam)	Automation SL (Midrail Automation)	Automation SL Ladder (Halfway Opp)	Automation SR (Auto Guy)	Sound Designer (Drew Levy)	AST Sound Designer (Maria Wurttle)	FOH Position (Tracy)	A2 SL (Rosio)	A3 SR	Conductor	Patrick	Paul	Marc	
A	CC1											IC 39 x3 XLR BOX			IC 34	IC 42	IC 63									CC1	CC1	CC1
B	CC2	IC 27	IC 41	IC 24			IC 37																			CC2	CC2	CC2
C	CC3				IC 25					IC 5																CC3	CC3	CC3
D	CC4																		IC 26		IC 11	IC 30	IC 33	IC 19	CC4	CC4	CC4	

SHOW MODE!

		COM PORT/ POSITION																				
Com Channel		CC1-CC8 Stage Manager	Deck Electric@ SL (Elizabeth)	Deck Electrician SR (Abby May)	Lighting Operator Booth	Spot Op #1	Spot Op #2	Fly 1 @SR (Jenny Tvorogova)	Fly 2 @SR (Colin Surra)	Fly 3 @SR (Zach Feivou)	SR Deck Automation (Sam)	Automation SL (Midrail Automation)	Automation SL Ladder (Halfway Opp)	Automation SR (Auto Guy)	FOH Position (Tracy)	A2 SL (Rosio)	A3 SR	Conductor	Patrick	Paul	Marc	
A	CC1							IC 39 x3 XLR BOX			IC 34	IC 34	IC 42	IC 63						CC1	CC1	CC1
B	CC2	IC 27	IC 41	IC 37																CC2	CC2	CC2
C	CC3					IC 5														CC3	CC3	CC3
D	CC4														IC 11	IC 30	IC 33	IC 19	CC4	CC4	CC4	

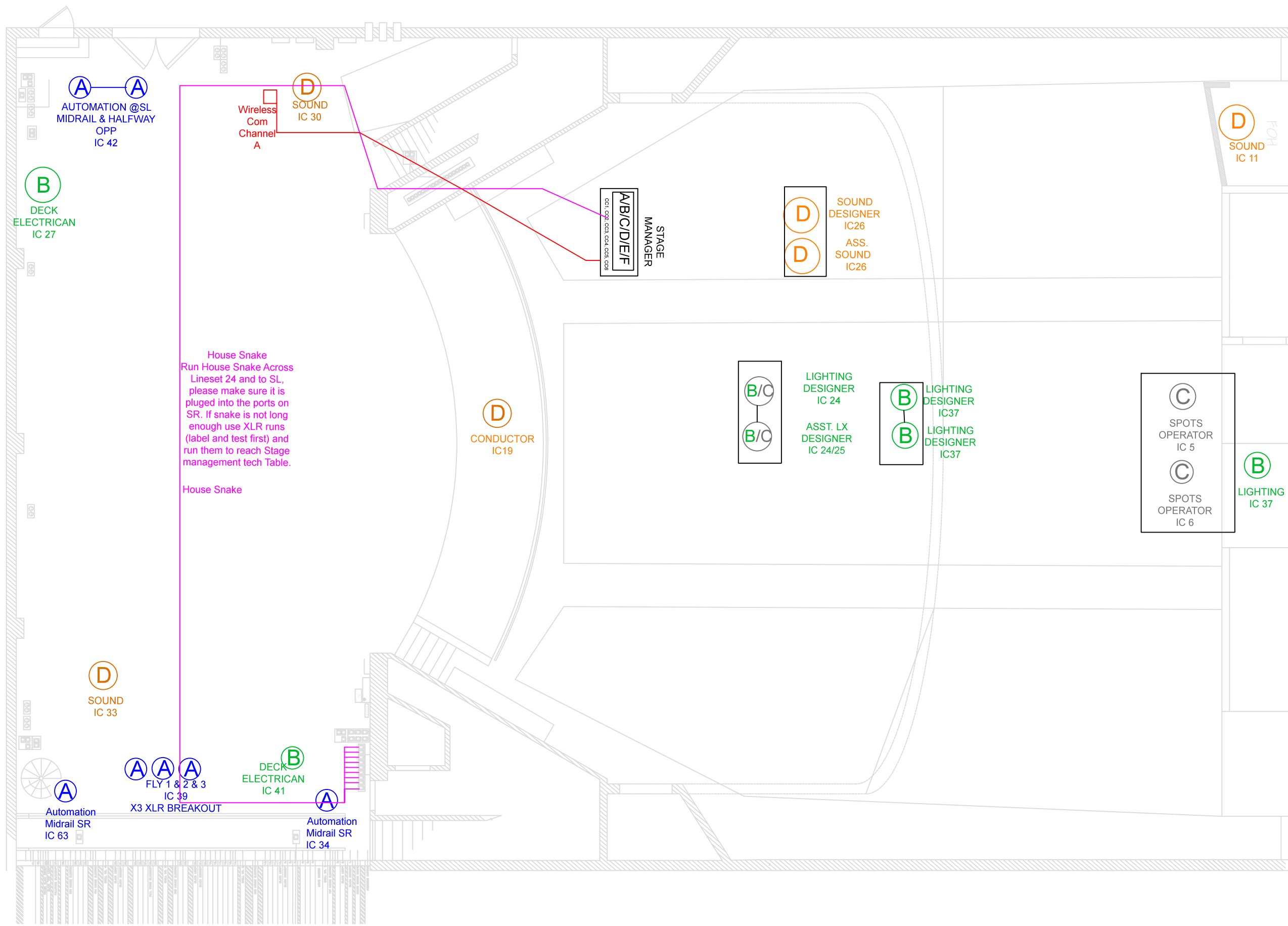

Tracy Cowit

Head Sound A1

Sound Designer
Drew Levy

Associate Sound Designer
Maria Wurttele

305.878.0893
wurttele.mf@artist.uncsa.edu

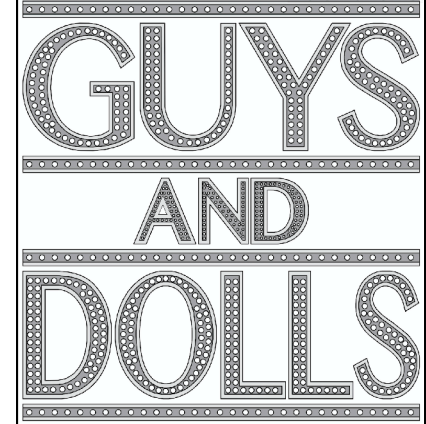

Venue
STEVENS CENTER

Producer
UNCSA

Director
GUS KAIKKONEN

Production Manager
DENNIS BOOTH

Scenic Designer
GARRET DAUB

Lighting Designer
AL CRAWFORD

Drawn By: TAC
File Name: Guys and Dolls v2015.dwg
Drawing Date: 04/25/15

Load-In Date 20 MARCH, 2015	Load-Out Date 19 APRIL, 2015
--------------------------------	---------------------------------

TECH INTERCOM LAYOUT

Plate
6.2

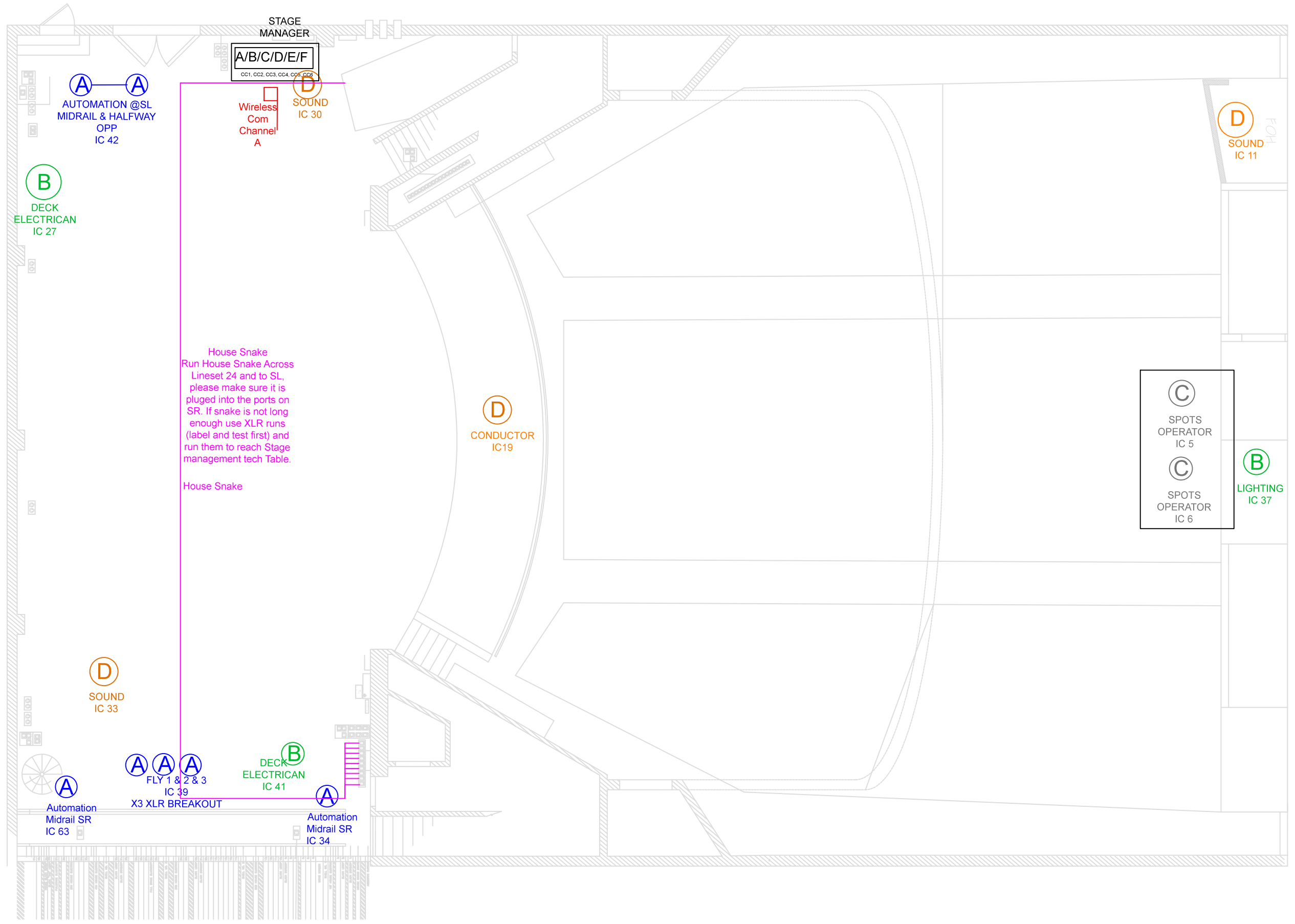

Tracy Cowit

Head Sound A1

Sound Designer
Drew Levy

Associate Sound Designer
Maria Wurttele

305.878.0893

wurttele.mf@artist.unca.edu

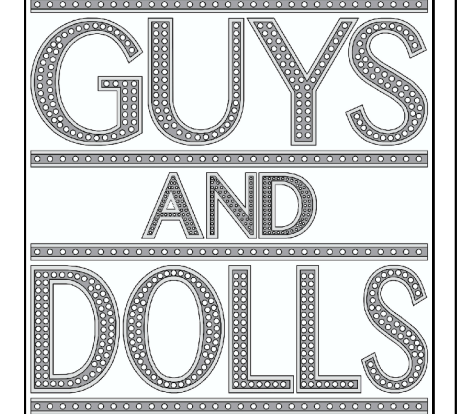

Venue

STEVENS CENTER

Producer

UNCSA

Director

GUS KAIKKONEN

Production Manager

DENNIS BOOTH

Scenic Designer

GARRET DAUB

Lighting Designer

AL CRAWFORD

Drawn By: TAC

File Name: Guys and Dolls v2015.dwg

Drawing Date: 04/25/15

Load-In Date

20 MARCH, 2015

Load-Out Date

19 APRIL, 2015

PERFORMANCE
INTERCOM LAYOUT

Plate
6.3

Guys and Dolls

Com Distribution v.5

**SUBJECT TO CHANGE

Com		
Channel	Who	Where
Wireless		
A/ISO	SM SL (Abigail)	
A/ISO	SM SR (Noam)	
A/ISO	Deck Carp SR	
A/ISO	ATD (Brendan)	
A/ISO	Spare	
A/ISO	Spare	
A/ISO	Spare	
A/ISO	Out For Repair	
Wired		
A	Spare	DSL
A	Spare	DSR
A	SM House	House
B	LX Board Op	LX Booth
B	LX Prog. 1	LX Tech Table
B	LX Prog. 2	LX Tech Table
B	Deck Electrician	SL
B	Deck Electrician	SR
B/C	LD	LX Tech Table
B/C	ALD	LX Tech Table
C	Spot 1	Spot Booth
C	Spot 2	Spot Booth
D	Conductor	Pit
D	Sound Mix	FOH
D	SD	Sound Tech Table
D	ASD	Sound Tech Table
D	A2	SL
D	A3	SR
A	Automation SL	Midrail SL
A	Automation SR	Midrail SR
A	Fly 1	Flyrail
A	Fly 2/Spare	Flyrail
A	Deck Carp SL	SL
A	Deck Carp SR	SR

Radios	
#	Who
Load-In	
1	Scenic
2	Scenic
3	LX
4	LX
5	LX
6	Sound
7	Sound
8	Automation
9	Scenic
Tech	
1	Scenic - Brendan
2	Scenic - Eric
3	LX - Dwyer
4	LX - Abby
5	Props - Jess
6	Sound - Tracy
7	Sound - Rosio
8	SM - Andrew
9	SM - Emma
Dress+Performances	
1	Scenic - Brendan
2	Scenic - Eric
3	LX - Dwyer
4	W&MU - Jill
5	Props - Jess
6	Sound - Tracy
7	Costumes -
8	SM - Andrew
9	SM - Emma

Sound Designer: Drew Levy
 Associate Sound Designer: Maria Wurttle
 Assistant Sound Designer: Graham Schwartz
 A1: Tracy Cowit

Tracy Cowit
Head Sound A1

Sound Designer
 Drew Levy

Associate Sound Designer
Maria Wurttele
 305.878.0893
 wurttele.mf@artist.uncsa.edu

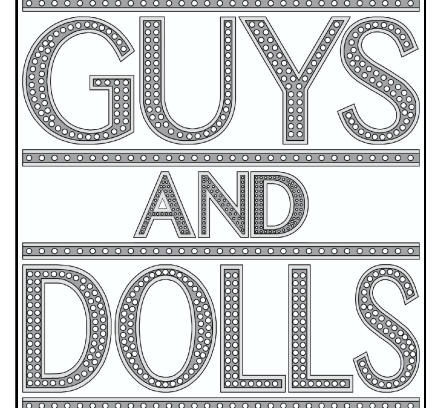

Venue
 STEVENS CENTER

Producer
 UNCSA

Director
 GUS KAIKKONEN

Production Manager
 DENNIS BOOTH

Scenic Designer
 GARRET DAUB

Lighting Designer
 AL CRAWFORD

Drawn By: MW/ Updates By: TAC & GTS
 File Name: Guys and Dolls v2015.dwg
 Drawing Date: 04/25/15

Load-In Date 20 MARCH, 2015	Load-Out Date 19 APRIL, 2015
--------------------------------	---------------------------------

COM DISTRIBUTION
V.5

Plate
6.4

Guys & Dolls

Show Information

Venue: SCPA
 Address:
 Phone:
 Fax:
 E-mail:
 Notes:

Customer Information

Point of Contact:
 Address:
 Phone:
 Fax:
 E-mail:

Inventory Report

Zone: Com

Active Channels (8)

Model	Band	Channel Name	Device ID	Frequency	Tags
No Inclusion Group (8)					
Pro 850 Base Station	2	HME	Pro 850 Base Station	G:-- 513.400 MHz	<input type="checkbox"/>
Pro 850 Base Station	2	HME	Pro 850 Base Station	G:-- 515.475 MHz	<input type="checkbox"/>
Pro 850 Base Station	2	HME	Pro 850 Base Station	G:-- 516.525 MHz	<input type="checkbox"/>
Pro 850 Base Station	2	HME	Pro 850 Base Station	G:-- 522.225 MHz	<input type="checkbox"/>
Pro 850 Belt Pack	A	HME	Pro 850 Belt Pack	G:-- 657.525 MHz	<input type="checkbox"/>
Pro 850 Belt Pack	A	HME	Pro 850 Belt Pack	G:-- 659.825 MHz	<input type="checkbox"/>
Pro 850 Belt Pack	A	HME	Pro 850 Belt Pack	G:-- 656.275 MHz	<input type="checkbox"/>
Pro 850 Belt Pack	A	HME	Pro 850 Belt Pack	G:-- 658.950 MHz	<input type="checkbox"/>

Model	Band	Channel Name	Device ID	Frequency	Tags
Belt Pack			Belt Pack	Ch:-- MHz	
Backup Frequencies (6) Frequency List Source: WWB					
Type	Band	Frequency			
No Inclusion Group (6)					
Pro 850 Base Station	2			G:-- 522.850 MHz	<input type="checkbox"/>
Pro 850 Base Station	2			G:-- 523.725 MHz	<input type="checkbox"/>
Pro 850 Belt Pack	A			G:-- 661.400 MHz	<input type="checkbox"/>
Pro 850 Belt Pack	A			G:-- 664.250 MHz	<input type="checkbox"/>
Pro 850 Belt Pack	A			G:-- 664.600 MHz	<input type="checkbox"/>
Pro 850 Belt Pack	A			G:-- 666.325 MHz	<input type="checkbox"/>

Zone: Default

Active Channels (34)

Model	Band	Channel Name	Device ID	Frequency	Tags
No Inclusion Group (34)					
ULX	J1	28-M.E. #4	ULX 28	G:01 556.375 MHz	<input type="checkbox"/>
ULX	J1	29-M.E. #5	ULX 29	G:08 557.675 MHz	<input type="checkbox"/>
ULX	J1	30-M.E. #6	ULX 30	G:10 567.600 MHz	<input type="checkbox"/>
ULX	J1	SPARE	ULX SPARE	G:10 569.900 MHz	<input type="checkbox"/>
ULX	M1	23-CALVIN	ULX 23	G:10 662.125 MHz	<input type="checkbox"/>
ULX	M1	24-ARVIDE	ULX 24	G:10 663.050 MHz	<input type="checkbox"/>
ULX	M1	25-JOEY BILT	ULX 25	G:01 663.725 MHz	<input type="checkbox"/>
ULX	M1	26-BIG JULE	ULX 26	G:09 665.575 MHz	<input type="checkbox"/>

Tracy Cowit

Head Sound A1

Sound Designer
Drew Levy

Associate Sound Designer

Maria Wurttele

305.878.0893

wurttele.mf@artist.unca.edu

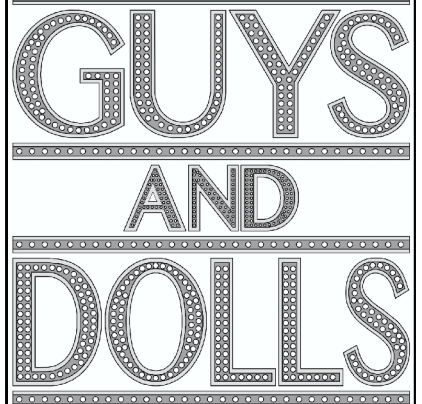

Venue

STEVENS CENTER

Producer

UNCSA

Director

GUS KAIKKONEN

Production Manager

DENNIS BOOTH

Scenic Designer

GARRET DAUB

Lighting Designer

AL CRAWFORD

Drawn By: TAC

File Name: Guys and Dolls v2015.dwg

Drawing Date: 04/25/15

Load-In Date

20 MARCH, 2015

Load-Out Date

19 APRIL, 2015

**WIRELESS
WORKBENCH FQ LIST**

Plate
7.1

Tracy Cowit

Head Sound A1

Sound Designer

Drew Levy

Associate Sound Designer

Maria Wurttele

305.878.0893

wurttele.mf@artist.uncsa.edu

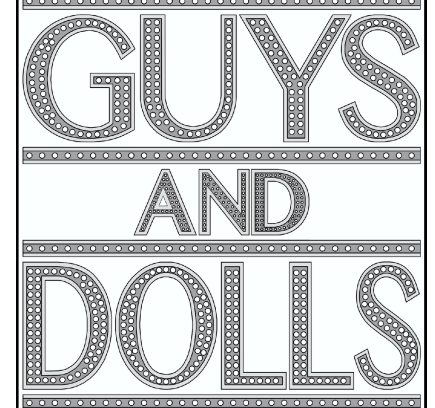

Venue

STEVENS CENTER

Producer

UNCSA

Director

GUS KAIKKONEN

Production Manager

DENNIS BOOTH

Scenic Designer

GARRET DAUB

Lighting Designer

AL CRAWFORD

Drawn By: TAC

File Name: Guys and Dolls v2015.dwg

Drawing Date: 04/25/15

Load-In Date

20 MARCH, 2015

Load-Out Date

19 APRIL, 2015

**WIRELESS
WORKBENCH FQ LIST**

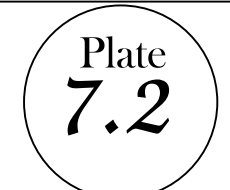

Model	Band	Channel Name	Device ID	Frequency	Tags	
ULX	M1	27-M.E. #1	ULX 27	G:03 Ch:04	667.175 MHz	<input type="checkbox"/>
ULX	M1	SPARE	ULX SPARE	G:10 Ch:05	667.800 MHz	<input type="checkbox"/>
ULXD4Q	H50	1-BENNY	ULXD4Q1	G:-- Ch:--	554.275 MHz	<input type="checkbox"/>
ULXD4Q	H50	10-M.E#2	ULXD4Q3	G:-- Ch:--	535.850 MHz	<input type="checkbox"/>
ULXD4Q	H50	11-M.E#3	ULXD4Q3	G:-- Ch:--	545.975 MHz	<input type="checkbox"/>
ULXD4Q	H50	2-NATHAN	ULXD4Q1	G:-- Ch:--	555.500 MHz	<input type="checkbox"/>
ULXD4Q	H50	3-CRTWRT	ULXD4Q1	G:-- Ch:--	557.200 MHz	<input type="checkbox"/>
ULXD4Q	H50	4-HARRY	ULXD4Q1	G:-- Ch:--	558.500 MHz	<input type="checkbox"/>
ULXD4Q	H50	5-SKY	ULXD4Q2	G:-- Ch:--	559.850 MHz	<input type="checkbox"/>
ULXD4Q	H50	6-LTBRAN	ULXD4Q2	G:-- Ch:--	568.250 MHz	<input type="checkbox"/>
ULXD4Q	H50	7-MC/ANG	ULXD4Q2	G:-- Ch:--	569.200 MHz	<input type="checkbox"/>
ULXD4Q	H50	8-NICELY	ULXD4Q2	G:-- Ch:--	570.400 MHz	<input type="checkbox"/>
ULXD4Q	H50	9-RUSTY	ULXD4Q3	G:-- Ch:--	535.275 MHz	<input type="checkbox"/>
ULXD4Q	H50	SPARE	ULXD4Q3	G:-- Ch:--	546.350 MHz	<input type="checkbox"/>
UR4D	G1	12-ADELAIDE	1	G:-- Ch:--	494.225 MHz	<input type="checkbox"/>
UR4D	G1	13-MARTHA	1	G:-- Ch:--	494.950 MHz	<input type="checkbox"/>
UR4D	G1	14-SARAH	2	G:-- Ch:--	514.525 MHz	<input type="checkbox"/>
UR4D	G1	15-AGATHA	2	G:-- Ch:--	514.975 MHz	<input type="checkbox"/>
UR4D	G1	16-MIMI	3	G:-- Ch:--	491.150 MHz	<input type="checkbox"/>
UR4D	G1	17-F.E. #1	3	G:--	493.300	<input type="checkbox"/>

Model	Band	Channel Name	Device ID	Frequency	Tags	
				Ch:--	MHz	
UR4D	G1	18-F.E. #2	4	G:-- Ch:--	495.875 MHz	<input type="checkbox"/>
UR4D	G1	19-F.E. #3	4	G:-- Ch:--	497.800 MHz	<input type="checkbox"/>
UR4D	G1	20-F.E. #4	5	G:-- Ch:--	498.175 MHz	<input type="checkbox"/>
UR4D	G1	21-F.E. #5	5	G:-- Ch:--	499.525 MHz	<input type="checkbox"/>
UR4D	G1	22-F.E. #6	6	G:-- Ch:--	512.225 MHz	<input type="checkbox"/>
UR4D	G1	SPARE	6	G:-- Ch:--	513.750 MHz	<input type="checkbox"/>

Backup Frequencies (7) Frequency List Source: WWB

Type	Band	Frequency	Tags
No Inclusion Group (7)			
UHFR	G1	G:-- Ch:--	517.025 MHz <input type="checkbox"/>
UHFR	G1	G:-- Ch:--	517.450 MHz <input type="checkbox"/>
ULX	M1	G:04 Ch:08	674.700 MHz <input type="checkbox"/>
ULX	M1	G:03 Ch:09	675.550 MHz <input type="checkbox"/>
ULX	M1	G:03 Ch:11	678.300 MHz <input type="checkbox"/>
ULX	M1	G:08 Ch:08	679.150 MHz <input type="checkbox"/>
ULXD	H50	G:-- Ch:--	571.825 MHz <input type="checkbox"/>

Frequency Coordination Parameters

Exclusions

Active TV Channels (21)

Type	Channels
Digital	14, 15, 16, 19, 20, 23, 25, 27, 29, 31, 32, 33, 34, 35, 39, 40, 43, 44, 47, 50, 51

Other Exclusions (69)

Type	Source	Frequency	Notes
Range	Manual	470.000 MHz - 487.000 MHz	<input type="checkbox"/>
Range	Manual	477.000 MHz - 478.000 MHz	<input type="checkbox"/>
Range	Manual	484.800 MHz - 484.900 MHz	<input type="checkbox"/>
Single	Manual	489.598 MHz	<input type="checkbox"/>
Range	Scan	500.138 MHz - 500.461 MHz	<input type="checkbox"/>
Range	Scan	500.500 MHz - 500.500 MHz	<input type="checkbox"/>
Range	Scan	500.538 MHz - 501.300 MHz	<input type="checkbox"/>
Range	Scan	501.342 MHz - 501.382 MHz	<input type="checkbox"/>
Range	Scan	501.425 MHz - 501.500 MHz	<input type="checkbox"/>
Range	Scan	501.592 MHz - 502.157 MHz	<input type="checkbox"/>
Range	Scan	502.200 MHz - 502.200 MHz	<input type="checkbox"/>
Range	Scan	502.300 MHz - 502.325 MHz	<input type="checkbox"/>
Range	Scan	502.363 MHz - 502.450 MHz	<input type="checkbox"/>
Range	Scan	502.500 MHz - 502.500 MHz	<input type="checkbox"/>
Range	Scan	502.600 MHz - 502.600 MHz	<input type="checkbox"/>
Range	Scan	502.650 MHz - 503.107 MHz	<input type="checkbox"/>
Range	Scan	503.142 MHz - 503.811 MHz	<input type="checkbox"/>
Range	Scan	503.850 MHz - 503.882 MHz	<input type="checkbox"/>
Range	Scan	503.925 MHz - 505.900 MHz	<input type="checkbox"/>
Range	Scan	508.311 MHz - 508.688 MHz	<input type="checkbox"/>

Type	Source	Frequency	Notes
Range	Scan	518.167 MHz - 518.682 MHz	<input type="checkbox"/>
Single	Manual	518.280 MHz	<input type="checkbox"/>
Single	Manual	518.400 MHz	<input type="checkbox"/>
Range	Scan	518.900 MHz - 518.900 MHz	<input type="checkbox"/>
Range	Scan	518.992 MHz - 522.050 MHz	<input type="checkbox"/>
Range	Scan	522.092 MHz - 522.107 MHz	<input type="checkbox"/>
Range	Scan	522.575 MHz - 522.575 MHz	<input type="checkbox"/>
Range	Scan	522.625 MHz - 522.625 MHz	<input type="checkbox"/>
Range	Scan	522.875 MHz - 522.875 MHz	<input type="checkbox"/>
Range	Scan	523.225 MHz - 523.225 MHz	<input type="checkbox"/>
Range	Scan	523.525 MHz - 523.661 MHz	<input type="checkbox"/>
Range	Scan	524.150 MHz - 526.032 MHz	<input type="checkbox"/>
Range	Scan	526.067 MHz - 526.150 MHz	<input type="checkbox"/>
Range	Scan	526.192 MHz - 526.207 MHz	<input type="checkbox"/>
Range	Scan	526.242 MHz - 529.807 MHz	<input type="checkbox"/>
Single	Manual	548.280 MHz	<input type="checkbox"/>
Range	Scan	548.312 MHz - 548.353 MHz	<input type="checkbox"/>
Range	Scan	548.396 MHz - 548.404 MHz	<input type="checkbox"/>
Range	Scan	548.575 MHz - 551.112 MHz	<input type="checkbox"/>
Range	Scan	551.137 MHz - 551.387 MHz	<input type="checkbox"/>
Range	Scan	551.412 MHz - 551.475 MHz	<input type="checkbox"/>

Tracy Cowit

Head Sound A1

Sound Designer

Drew Levy

Associate Sound Designer

Maria Wurttele

305.878.0893

wurttele.mf@artist.uncsa.edu

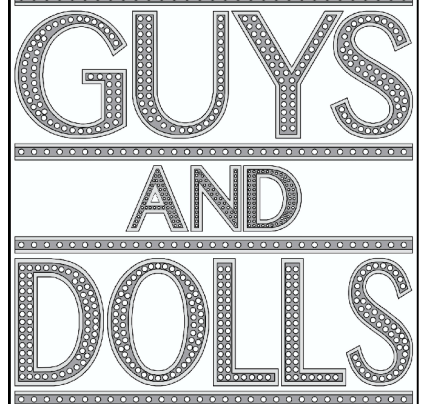

Venue

STEVENS CENTER

Producer

UNCSA

Director

GUS KAIKKONEN

Production Manager

DENNIS BOOTH

Scenic Designer

GARRET DAUB

Lighting Designer

AL CRAWFORD

Drawn By: TAC

File Name: Guys and Dolls v2015.dwg

Drawing Date: 04/25/15

Load-In Date

20 MARCH, 2015

Load-Out Date

19 APRIL, 2015

**WIRELESS
WORKBENCH FQ LIST**

Plate
7.3

Tracy Cowit

Head Sound A1

Sound Designer
Drew Levy

Associate Sound Designer
Maria Wurttele
305.878.0893
wurttele.mf@artist.uncsa.edu

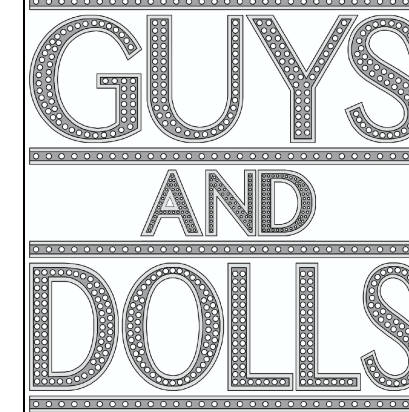

Venue
STEVENS CENTER

Producer
UNCSA

Director
GUS KAIKKONEN

Production Manager
DENNIS BOOTH

Scenic Designer
GARRET DAUB

Lighting Designer
AL CRAWFORD

Drawn By: TAC
File Name: Guys and Dolls v2015.dwg
Drawing Date: 04/25/15

Load-In Date 20 MARCH, 2015	Load-Out Date 19 APRIL, 2015
--------------------------------	---------------------------------

WIRELESS
WORKBENCH FQ LIST

Plate
7.4

Type	Source	Frequency	Notes
Range	Scan	551.525 MHz - 551.550 MHz	<input type="checkbox"/>
Range	Scan	552.450 MHz - 552.450 MHz	<input type="checkbox"/>
Range	Scan	560.204 MHz - 563.156 MHz	<input type="checkbox"/>
Range	Scan	563.190 MHz - 563.212 MHz	<input type="checkbox"/>
Range	Scan	563.375 MHz - 563.668 MHz	<input type="checkbox"/>
Range	Scan	563.681 MHz - 563.737 MHz	<input type="checkbox"/>
Range	Scan	563.766 MHz - 563.787 MHz	<input type="checkbox"/>
Range	Scan	563.825 MHz - 564.275 MHz	<input type="checkbox"/>
Range	Scan	564.325 MHz - 565.825 MHz	<input type="checkbox"/>
Range	Scan	572.068 MHz - 577.860 MHz	<input type="checkbox"/>
Range	Scan	577.900 MHz - 577.900 MHz	<input type="checkbox"/>
Range	Scan	578.075 MHz - 578.075 MHz	<input type="checkbox"/>
Range	Scan	578.114 MHz - 583.883 MHz	<input type="checkbox"/>
Range	Scan	584.192 MHz - 584.209 MHz	<input type="checkbox"/>
Range	Scan	584.239 MHz - 588.762 MHz	<input type="checkbox"/>
Range	Scan	588.875 MHz - 589.716 MHz	<input type="checkbox"/>
Range	Scan	589.750 MHz - 589.800 MHz	<input type="checkbox"/>
Range	Scan	589.837 MHz - 589.875 MHz	<input type="checkbox"/>
Range	Manual	590.000 MHz - 591.000 MHz	<input type="checkbox"/>
Range	Scan	590.250 MHz - 590.382 MHz	<input type="checkbox"/>

Type	Source	Frequency	Notes
Range	Scan	592.525 MHz - 592.525 MHz	<input type="checkbox"/>
Range	Scan	596.112 MHz - 596.137 MHz	<input type="checkbox"/>
Range	Scan	596.158 MHz - 598.000 MHz	<input type="checkbox"/>
Range	Manual	662.140 MHz - 662.750 MHz	<input type="checkbox"/>
Range	Manual	668.000 MHz - 668.300 MHz	<input type="checkbox"/>
Single	Manual	676.800 MHz	<input type="checkbox"/>
Single	Manual	684.325 MHz	GOD 1 <input type="checkbox"/>
Single	Manual	684.975 MHz	GOD 2 <input type="checkbox"/>

Created on 13 Apr 2015 at 3:52PM
Generated using Wireless Workbench 6.10.3.9

Benny Southstreet
578.625
ULXD4Q
Michael Calciano



Agatha/Ens
514.975
UR4D- D
Rachel Brooks

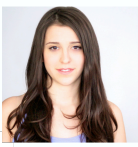

F. Ensemble 1
493.3
UR4D- F
Emily Hart



Nathan Detroit
555.500
ULXD4Q
Nick Gordon (Colon)



Calvin
662.125
ULXS4
G: 10 Ch: 01
Jonathan Downey



F. Ensemble 2
495.875
UR4D- G
Caroline Annichiarco



Sarah Brown
514.525
UR4D- C
Kira Geiger



Arvide Abernathy
663.050
ULXS4
G: 10 Ch: 02
Mason Hensley



F. Ensemble 3
497.8
UR4D- H
Courtnee Carter



Harry the Horse
558.500
ULXD4Q
Benton Guinness



Joey Biltmore/Ens
663.725
ULXS4
G: 01 Ch: 02
TJ Nelson



F. Ensemble 4
498.175
UR4D- I
Beth Hawkes



Sky Masterson
559.850
ULXD4Q
Kyle Habberstad



Mimi/Ens
491.15
UR4D- E
Samaria Pagge



F. Ensemble 5
499.525
UR4D- J
Savannah-Lee Mumford



Lt. Brannigan/Ens
568.250
ULXD4Q
Michael Johnson



Big Jule
665.575
ULXS4
G: 09 Ch: 04
Luis Quintero



F. Ensemble 6
512.225
UR4D- K
Chessa Metz



MC/Angie the Ox/Ens
569.200
ULXD4Q
Steven Maier



M. Ensemble 1
537.175
ULXD4Q
G: 03 Ch: 04
Andrew Manning



M. Ensemble 5
557.675
ULXP4
G: 08 Ch: 04
Joshua Pagan



Nicely Nicely Johnson
570.400
ULXD4Q
Joshua Popa



M. Ensemble 2
535.85
ULXD4Q
Graham Baker



M. Ensemble 6
567.6
ULXP4
G: 10 Ch: 09
Isaac Powell



Rusty Charlie
535.275
ULXD4Q
Noah Reece



M. Ensemble 3
545.975
ULXD4Q
Sam Geoffrey



Martha/Ens
494.950
UR4D- B
Jasmine Stiefel



Adelaide
494.225
UR4D- A
Meagan Smith



M. Ensemble 4
556.375
ULXP4
G: 01 Ch: 01
Stephen Kime



General Cartwright
557.200
ULXD4Q
Ashley Powers (Taylor)

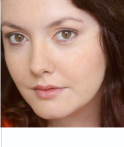

Tracy Cowit

Head Sound A1

Sound Designer
Drew Levy

Associate Sound Designer
Maria Wurttele
305.878.0893
wurttele.mf@artist.uncsa.edu

GUYS AND DOLLS

Venue
STEVENS CENTER

Producer
UNCSA

Director
GUS KAIKKONEN

Production Manager
DENNIS BOOTH

Scenic Designer
GARRET DAUB

Lighting Designer
AL CRAWFORD

Drawn By: TAC & RSM
File Name: Guys and Dolls v2015.dwg
Drawing Date: 04/25/15

Load-In Date 20 MARCH, 2015	Load-Out Date 19 APRIL, 2015
--------------------------------	---------------------------------

RF LABELS

Plate
7.5

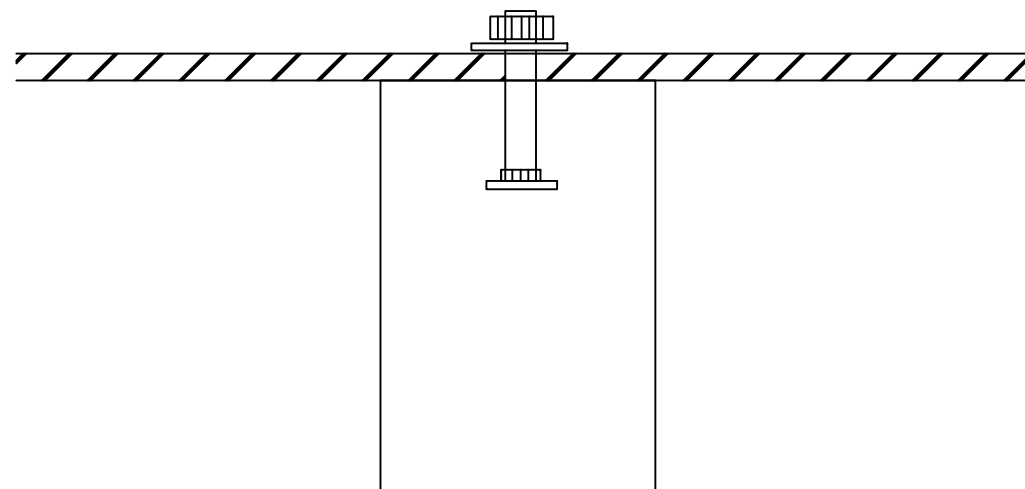
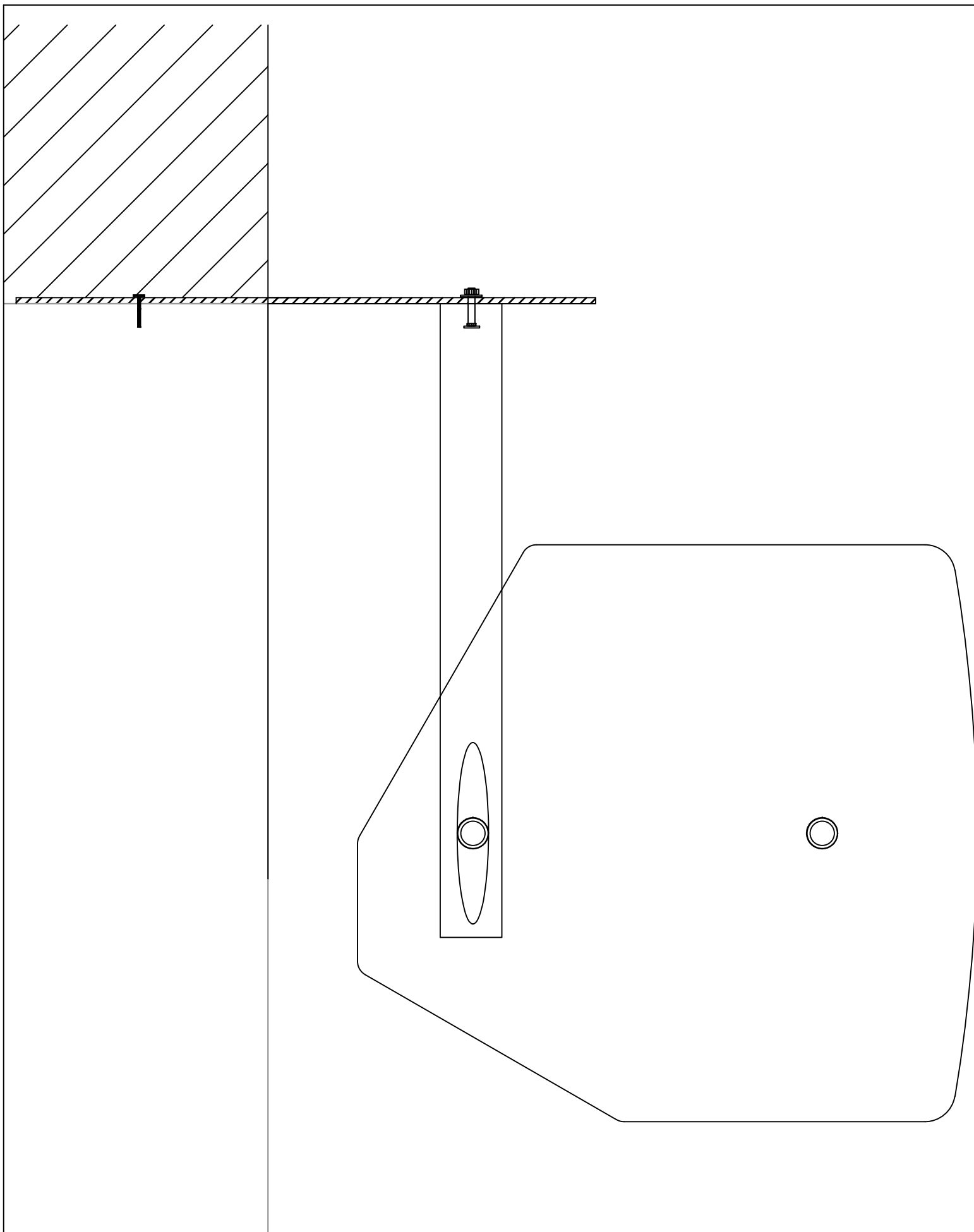

How to mount:

- 2 Bolts ($\frac{1}{2}$ "x3")
- 2 Nuts ($\frac{1}{2}$ "
- 2 washers ($\frac{1}{2}$ "
- E3 Side mounting bolts (3/8 " Bolts)
- (Z5028) d&b audio bracket

Total weight - 17lbs

Notes:

This speaker is mounted off the front of the stage to $\frac{1}{2}$ " Ply and screwed into the deck. Bracket is mounted with the use of 2 $\frac{1}{2}$ " bolts.

(The equipment listed above is for 1 speaker, if mounting more than one will need more hardware)

Speaker mounting will go in under the 6" deck that will be installed.

Weight of speaker: 15.9

Tracy Cowit

Head Sound A1

Sound Designer

Drew Levy

Associate Sound Designer

Maria Wurttele

305.878.0893

wurttele.mf@artist.uncsa.edu

**GUYS
AND
DOLLS**

Venue

STEVENS CENTER

Producer

UNCSA

Director

GUS KAIKKONEN

Production Manager

DENNIS BOOTH

Scenic Designer

GARRET DAUB

Lighting Designer

AL CRAWFORD

Drawn By: TAC

File Name: Guys and Dolls v2015.dwg

Drawing Date: 04/25/15

Load-In Date

20 MARCH, 2015

Load-Out Date

19 APRIL, 2015

FRONT FILL RIGGING

D&B E3

Plate

8.1

NTS

Tracy Cowit

Head Sound A1

Sound Designer
Drew Levy

Associate Sound Designer

Maria Wurtele

305.878.0893

wurtele.mf@artist.uncsa.edu

GUYS AND DOLLS

Venue

STEVENS CENTER

Producer

UNCSA

Director

GUS KAIKKONEN

Production Manager

DENNIS BOOTH

Scenic Designer

GARRET DAUB

Lighting Designer

AL CRAWFORD

Drawn By: TAC

File Name: Guys and Dolls v2015.dwg

Drawing Date: 04/25/15

Load-In Date

20 MARCH, 2015

Load-Out Date

19 APRIL, 2015

Y8 SOUND TRUSS ARRAY RIGGING

Plate
8.2

NTS

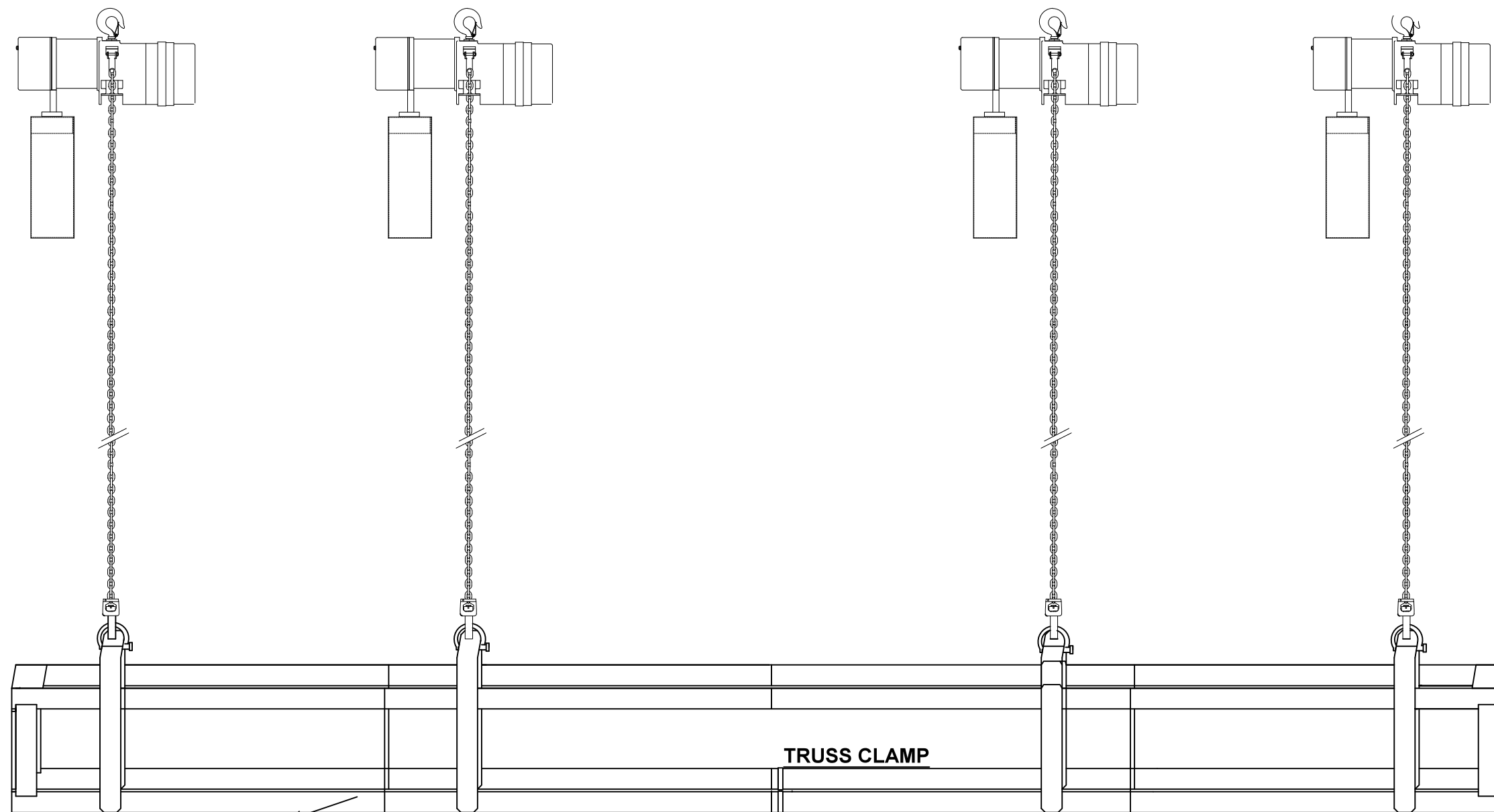

NOTES:

Hang Truss off center so the Array can hang @ Center

Items or hanging array:
2- 5/16" shackle

1- (Z5390.000) Y Flying frame w/ (2) lifting chains
6- (Z0707.002) Y8 Loudspeaker NLT4F/M

Two truss brackets holding the d&b flying frame, once show is complete please return brackets to film.

REAR pick load: 193lbs
FRONT pick load: 117lbs
Total sound lbs: 310lbs

SOUND TRUSS RIGGING:

40' Aluminum Truss (4 Motor Points)
16 - $\frac{3}{4}$ " Hex Bolt with Washer/Nut
12 - $\frac{3}{8}$ " HH 1" Bolt
12 $\frac{3}{8}$ " Washer
4 - 5/16" Shackles
2- Truss clamps

LIGHTING:

Hanging 16 Source 4's equal on both sides of speaker.
Estimated weight: 280lbs + cable

(Units 1-3 and 14-16 on US, the rest DS)

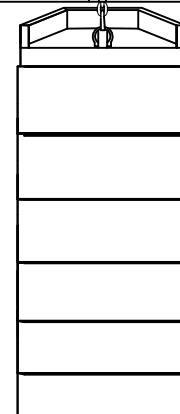

Tracy Cowit

Head Sound A1

Sound Designer
Drew Levy

Associate Sound Designer
Maria Wurttle
305.878.0893
wurttle.mf@artist.uncsa.edu

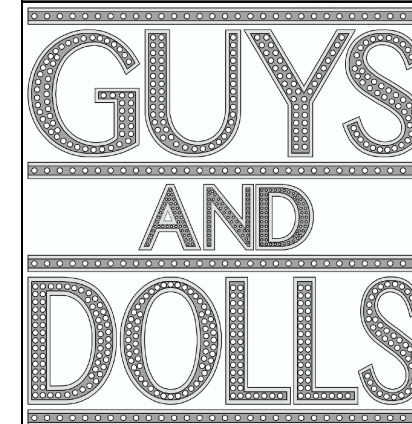

Venue
STEVENS CENTER

Producer
UNCSA

Director
GUS KAIKKONEN

Production Manager
DENNIS BOOTH

Scenic Designer
GARRET DAUB

Lighting Designer
AL CRAWFORD

Drawn By: TAC
File Name: Guys and Dolls v2015.dwg
Drawing Date: 03/05/15

Load-In Date 20 MARCH, 2015	Load-Out Date 19 APRIL, 2015
--------------------------------	---------------------------------

ORGAN BAY HL, HR
RIGGING

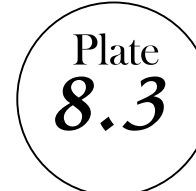

NTS

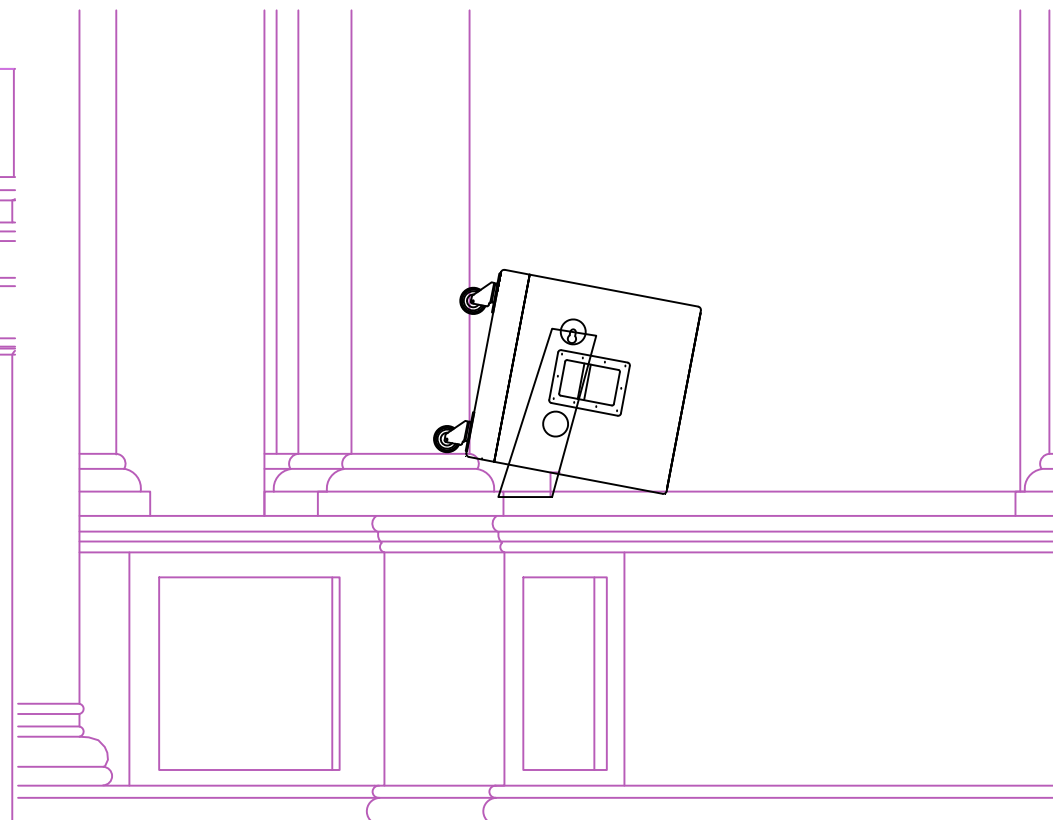
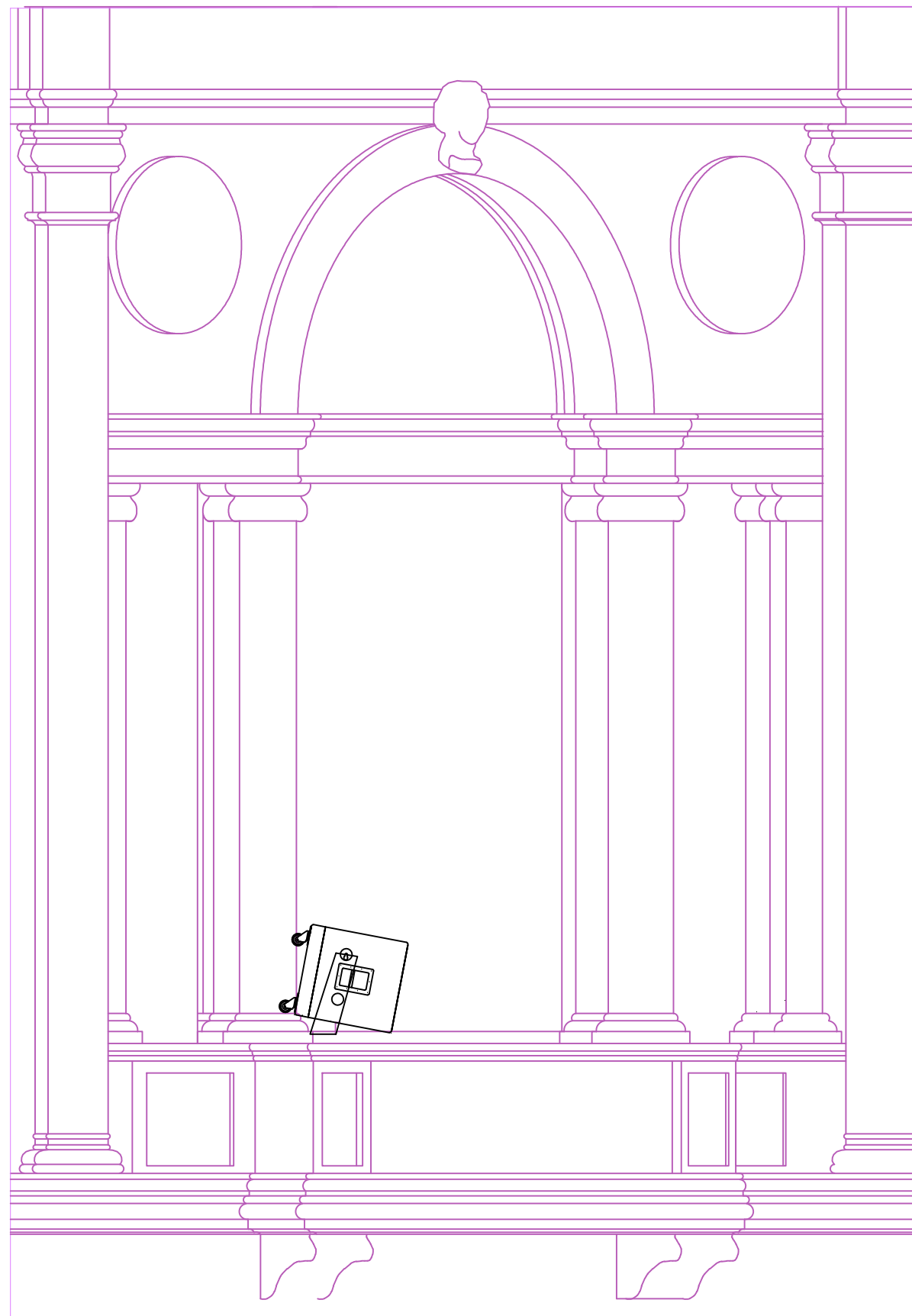

NOTES:

Speaker: C7 Top
Weight: 115 lbs
Angle -10 degrees

Possible: Use the ci7 top hanging bracke to get the required angle. Once angle has been achieved put stage weight behind speaker to keep it in place.

location tbd by designer on organ bay

Same location on both organ bays

another option would be to build some wedges. could be some 2x4's

Try the hanging frame first and see the stability.

Side View

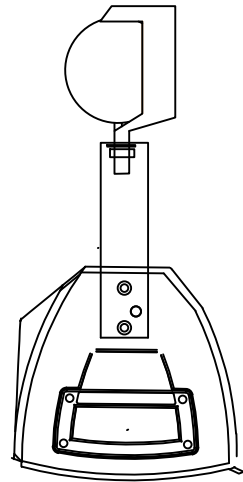

Front View

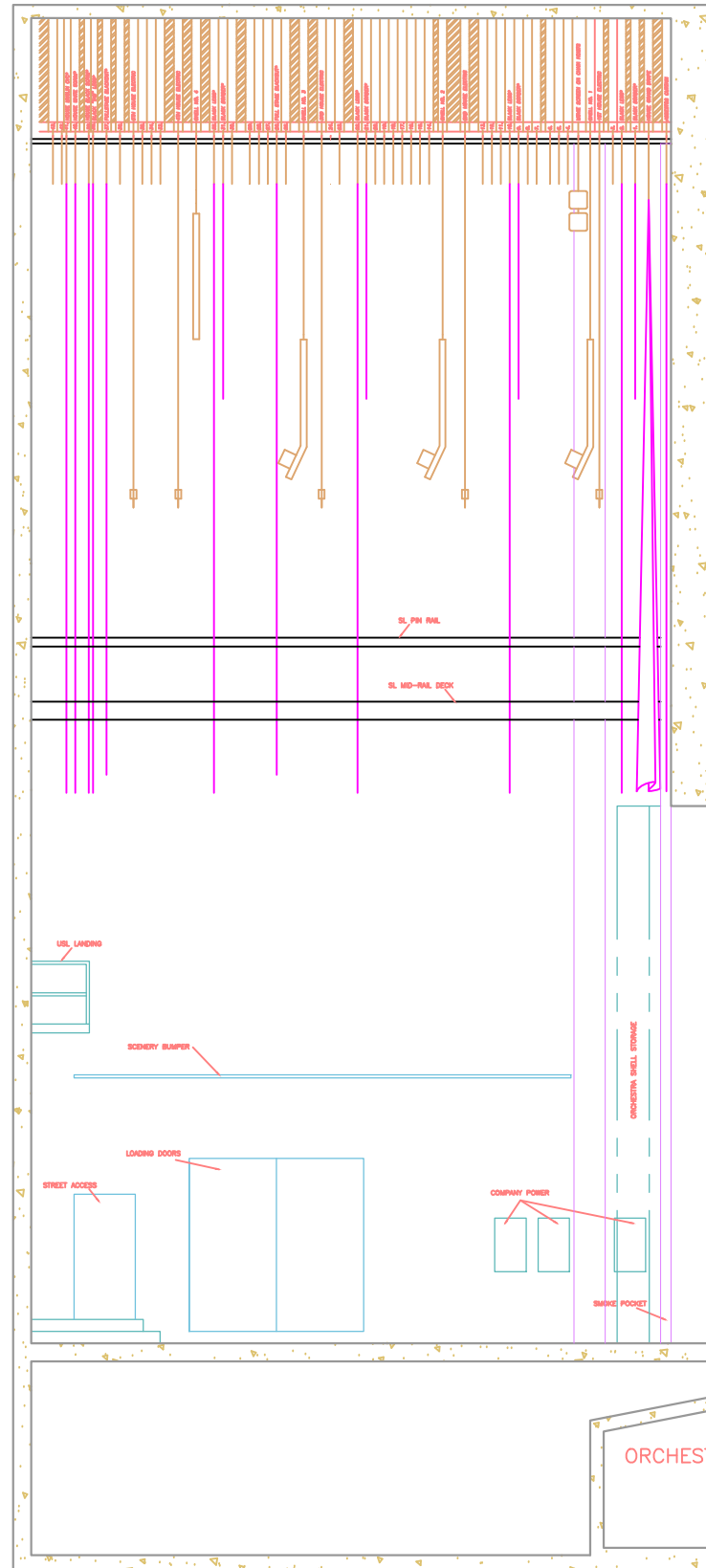
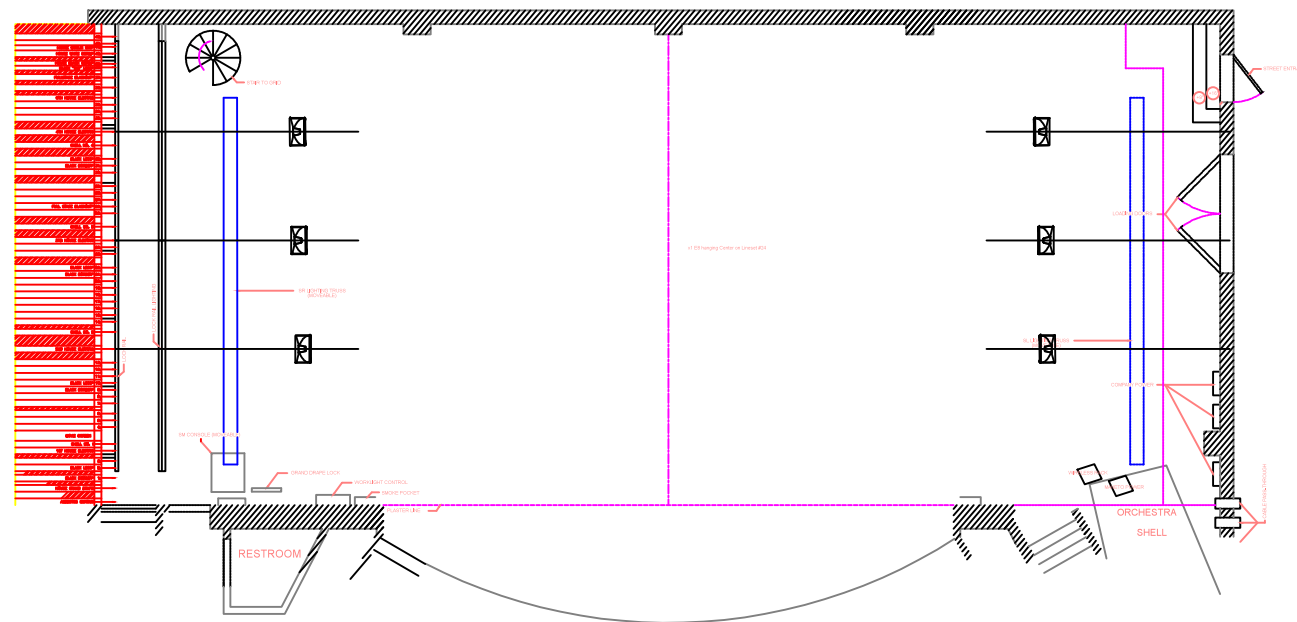
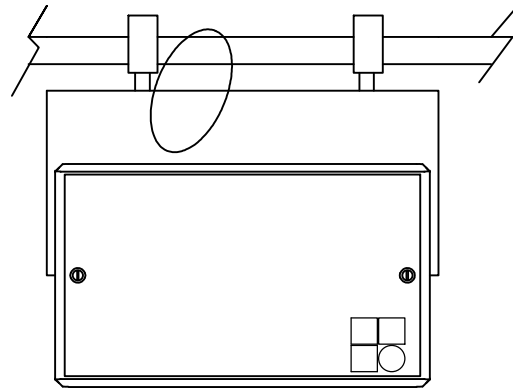

NOTES:
 SR cable runs will run up to the midrail on SR and tie in with cable swag with lightning incase the electric needs to come back in. Once swag is tied together cable runs up to the grid and over to SL.

SL cable runs will run up to the midrail on SL and tie in with cable swag with lightning incase electric needs to come back in. Once swag is tied together cable runs down to amp racks on SL.

Height and placement of speakers to be determined by designer in space.

Tracy Cowit
 Head Sound A1

Sound Designer
 Drew Levy

Associate Sound Designer
 Maria Wurttele
 305.878.0893
 wurttele.mf@artist.uncsa.edu

**GUYS
 AND
 DOLLS**

Venue
 STEVENS CENTER

Producer
 UNCSA

Director
 GUS KAIKKONEN

Production Manager
 DENNIS BOOTH

Scenic Designer
 GARRET DAUB

Lighting Designer
 AL CRAWFORD

Drawn By: TAC
 File Name: Guys and Dolls v2015.dwg
 Drawing Date: 04/25/15

Load-In Date: 20 MARCH, 2015
 Load-Out Date: 19 APRIL, 2015

**OH FOLDBACK
 RIGGING, PLACEMENT**

Plate
8.4

NTS

Rigging Bracket View

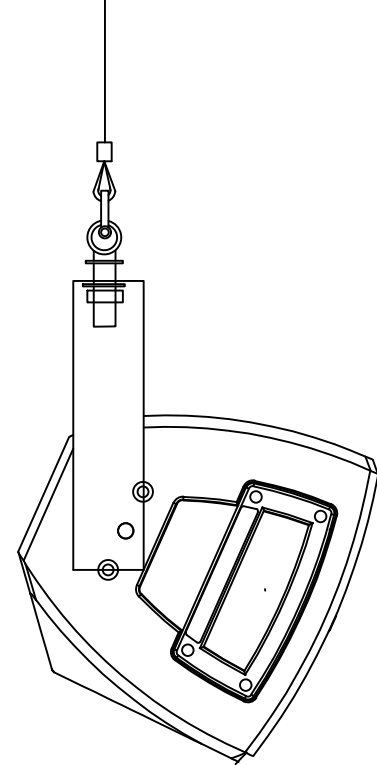
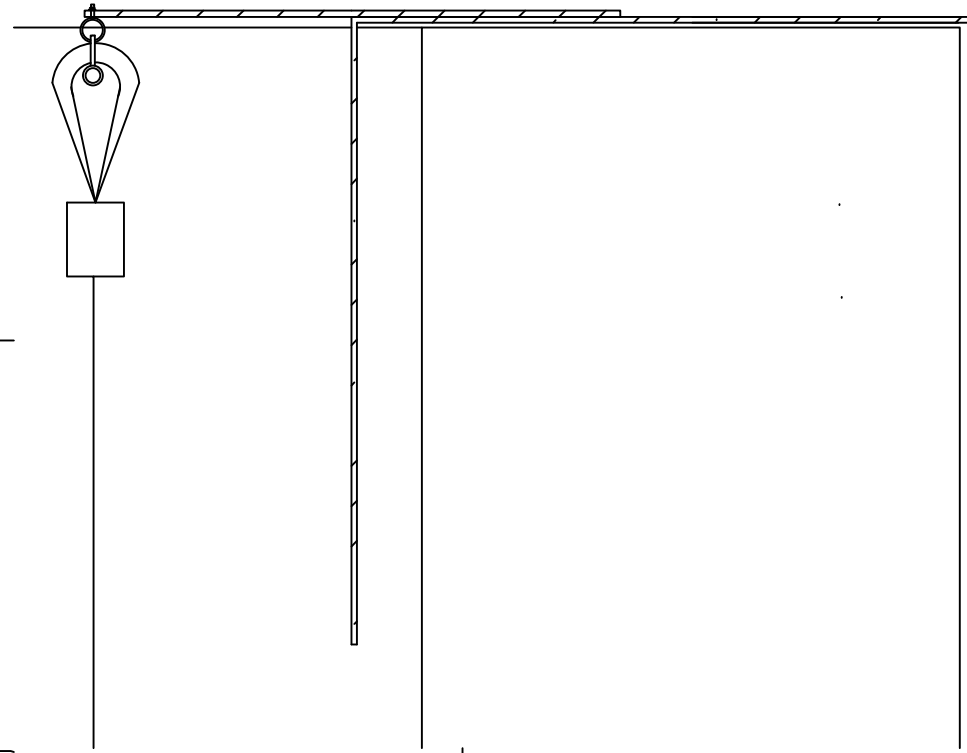
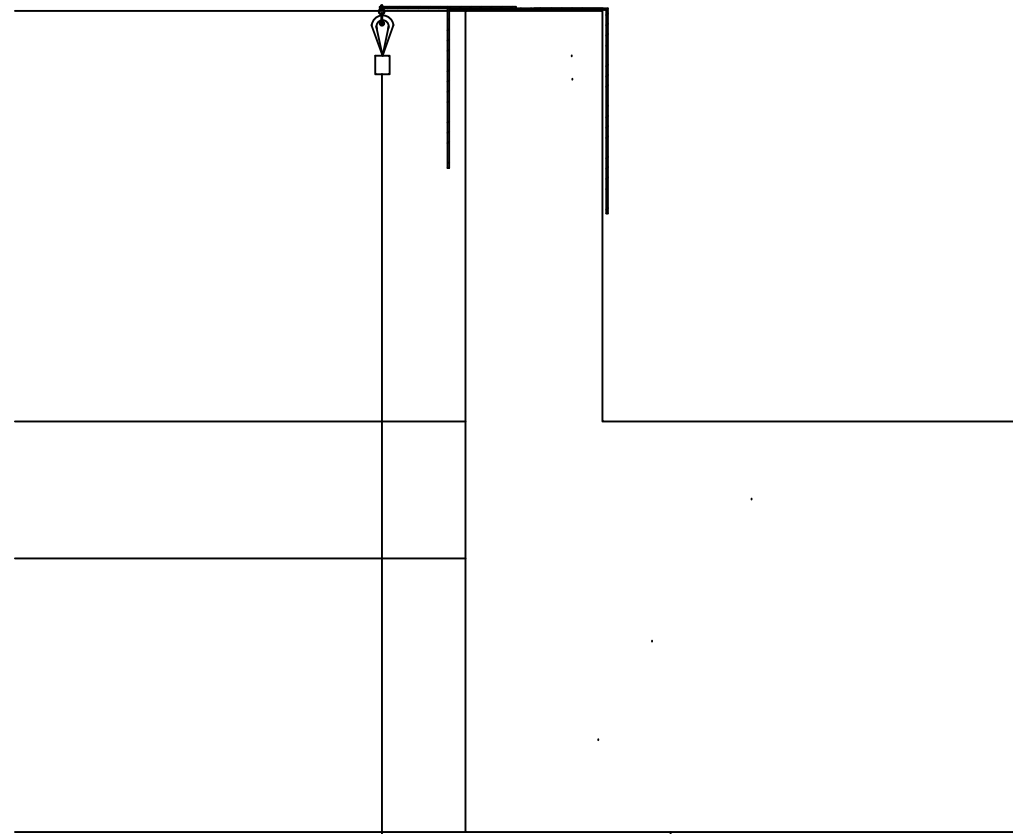

Side View

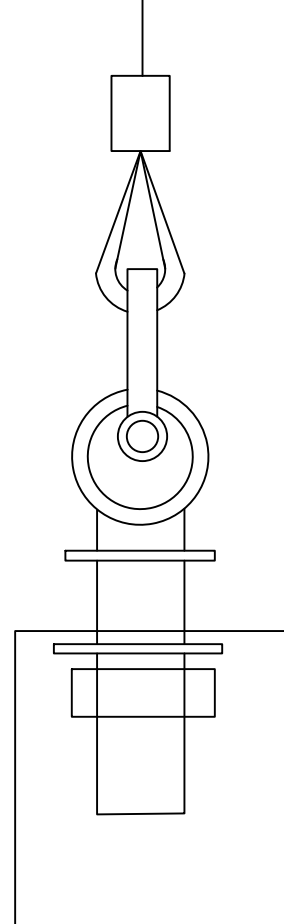

Bracket

NOTES:

- 3 UNCSA made Balcony Brackets
- 6 Safety Cables
- 3 E8 Speakers

- 6 stingers (3'6")
- 16 Thimbles
- 16 Swages
- 1/8" Aircraft Cable

- 16 Bolts (1/2"x4")
- 12 Shouldered Eye Bolts (5/16" diameter with 2" length)
- 16 Nuts (1/2")
- 16 Washers (1/2")
- Pieces of Duve to put under brackets (so we don't scratch the wood)

speaker weight: 16.1lbs
Total weight: 30lbs

RIGGING:

UNCSA homemade bracket rests on top of lip of mezzanine with Duve protecting wood from scrapes.

Tighten bolts to the width of the balcony...remember to do the stage side first.

Attach two stingers to the homemade bracket via two shackles on top.

Two Shackles on the hanging bracket attached to two more shouldered eye bolts.

Tracy Cowit

Head Sound A1

Sound Designer

Drew Levy

Associate Sound Designer

Maria Wurttelle

305.878.0893

wurttelle.mf@artist.uncsa.edu

**GUYS
AND
DOLLS**

Venue

STEVENS CENTER

Producer

UNCSA

Director

GUS KAIKKONEN

Production Manager

DENNIS BOOTH

Scenic Designer

GARRET DAUB

Lighting Designer

AL CRAWFORD

Drawn By: TAC

File Name: Guys and Dolls v2015.dwg

Drawing Date: 04/25/15

Load-In Date

20 MARCH, 2015

Load-Out Date

19 APRIL, 2015

UNDERBALC RIGGING

D&B E8

Plate
8.5

NTS

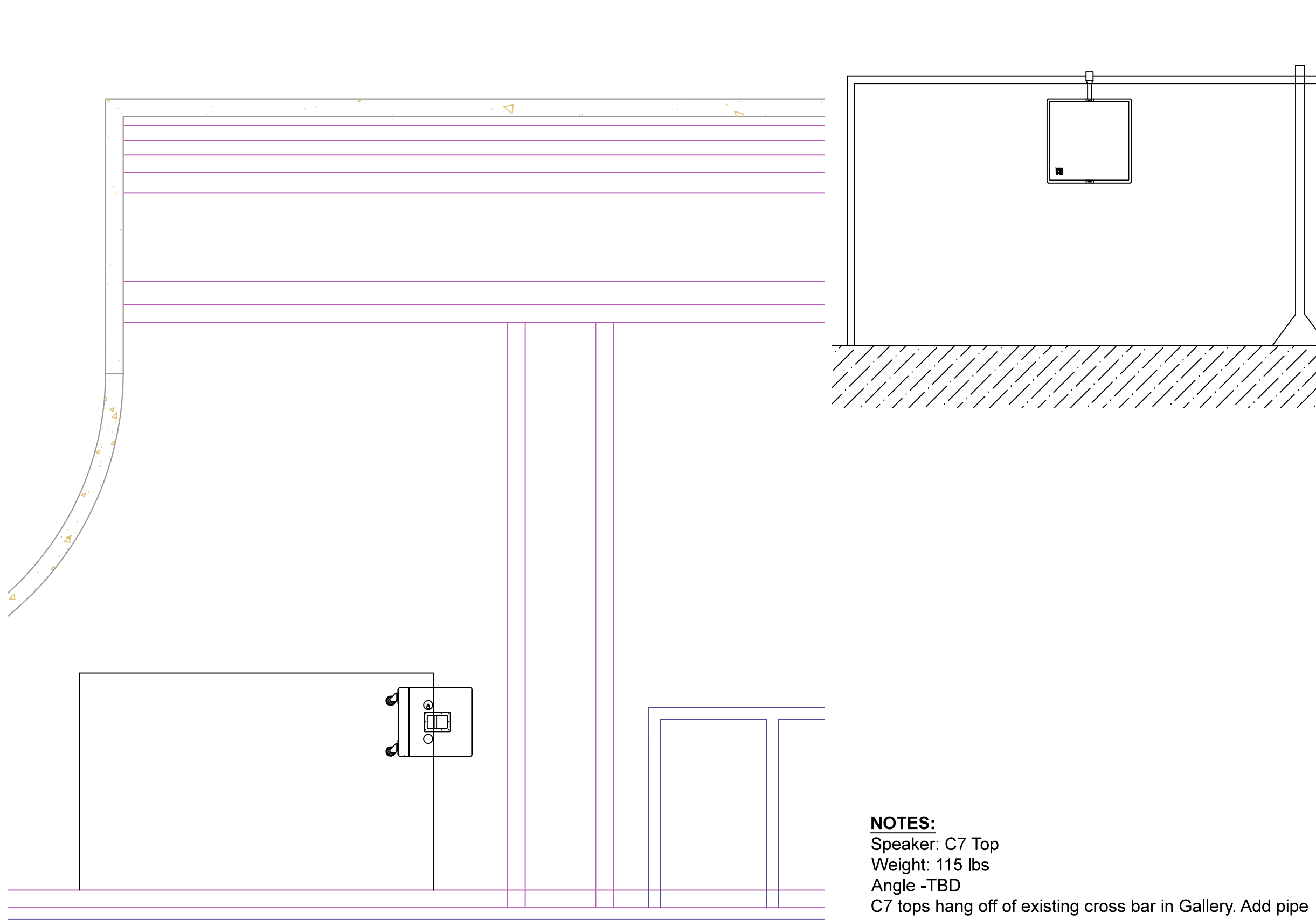

NOTES:
 Speaker: C7 Top
 Weight: 115 lbs
 Angle -TBD
 C7 tops hang off of existing cross bar in Gallery. Add pipe down to stabilize the weight of the C7.

Tracy Cowit

Head Sound A1

Sound Designer
Drew Levy

Associate Sound Designer
Maria Wurttele

305.878.0893
 wurttele.mf@artist.unca.edu

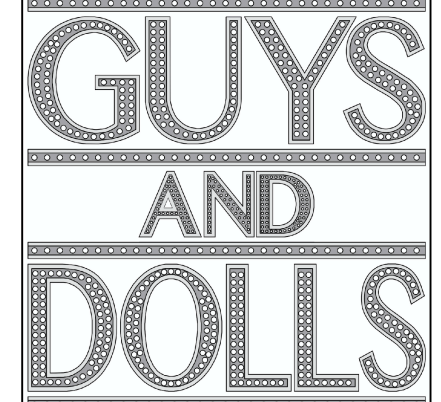

Venue
 STEVENS CENTER

Producer
 UNCSA

Director
 GUS KAIKKONEN

Production Manager
 DENNIS BOOTH

Scenic Designer
 GARRET DAUB

Lighting Designer
 AL CRAWFORD

Drawn By: TAC
 File Name: Guys and Dolls v2015.dwg
 Drawing Date: 04/25/15

Load-In Date 20 MARCH, 2015	Load-Out Date 19 APRIL, 2015
--------------------------------	---------------------------------

GALLERY RIGGING
D&B C7 Top

Plate
8.6

NTS

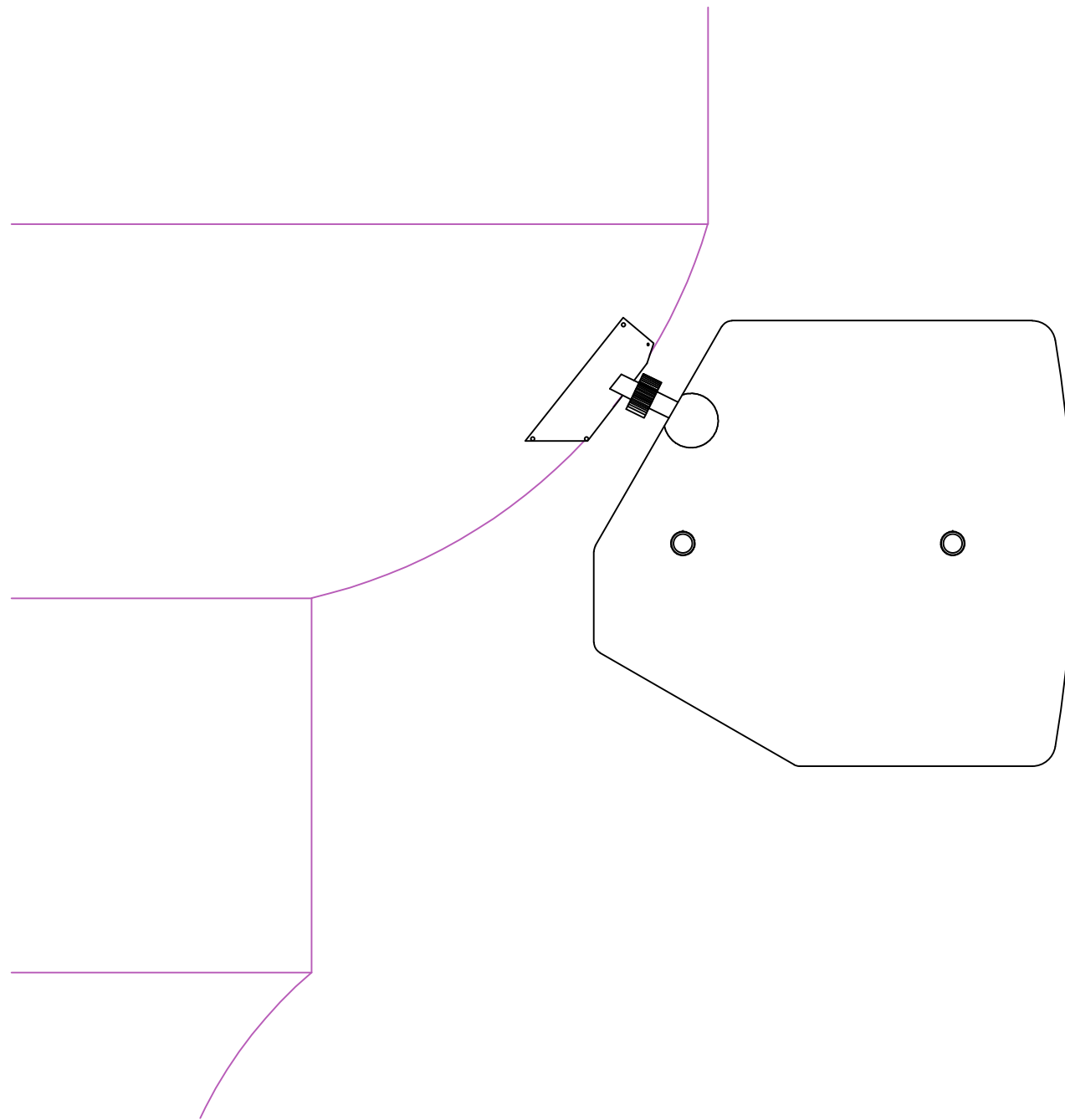

HARDWARE:

- 4 $\frac{3}{8}$ " Lock Washers
- B2123 d&b Fixing Plate
- x7 (Z0450.000) E5 Loudspeaker, NL4
- x7 (Z5356.000) E5 ball joint adapter.

Total weight: 6.0lbs

NOTES:

- This speaker is mounted sing he fixing plate which is located in the balcony.
- Use one lock washer for each speaker to keep the speaker to the plate.
- Tighten the nut on the speakers ball joint adapter to the fixing plate.
- To adhere the speaker use a c-wrench and turn the nut, not the speaker.

Tracy Cowit

Head Sound A1

Sound Designer

Drew Levy

Associate Sound Designer

Maria Wurttle

305.878.0893

wurttle.mf@artist.uncsa.edu

**GUYS
AND
DOLLS**

Venue

STEVENS CENTER

Producer

UNCSA

Director

GUS KAIKKONEN

Production Manager

DENNIS BOOTH

Scenic Designer

GARRET DAUB

Lighting Designer

AL CRAWFORD

Drawn By: TAC

File Name: Guys and Dolls v2015.dwg

Drawing Date: 04/25/15

Load-In Date

20 MARCH, 2015

Load-Out Date

19 APRIL, 2015

BALC FILLS x7
D&B E5 w/ ball joint adapter

Plate
8.7

NTS

3D plot

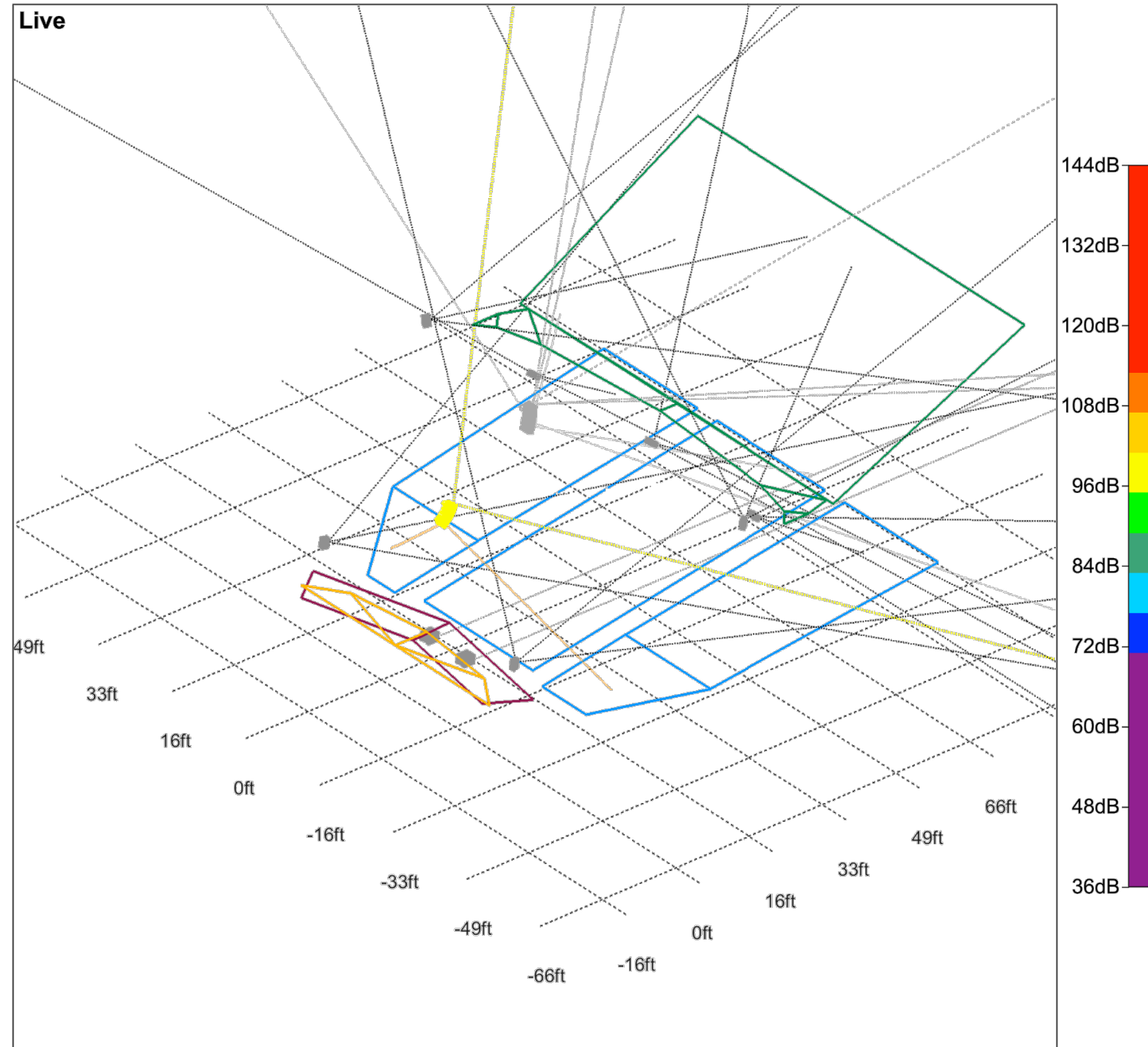

SPL calculation

Resolution:

Highest SPL:

Signal selection

Level (dBu):

Signal:

Show interferences:

Air absorption

On/Off:

Temperature:

Humidity:



Tracy Cowit

Head Sound A1

Sound Designer

Drew Levy

Associate Sound Designer

Maria Wurtele

305.878.0893

wurtele.mf@artist.uncsa.edu

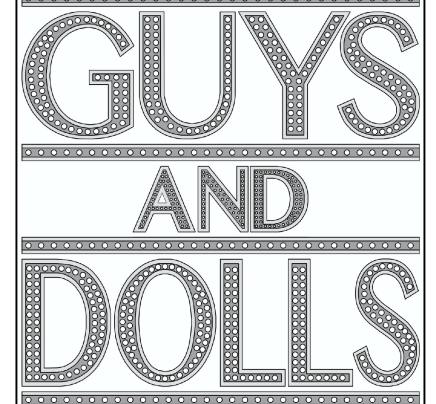

Venue

STEVENS CENTER

Producer

UNCSA

Director

GUS KAIKKONEN

Production Manager

DENNIS BOOTH

Scenic Designer

GARRET DAUB

Lighting Designer

AL CRAWFORD

Drawn By: Drew Levy/ Plated By: TAC

File Name: Guys and Dolls v2015.dwg

Drawing Date: 04/25/15

Load-In Date
20 MARCH, 2015

Load-Out Date
19 APRIL, 2015

ARRAY CALC
3D PLOT

Plate
9.1

Alignment

Top view

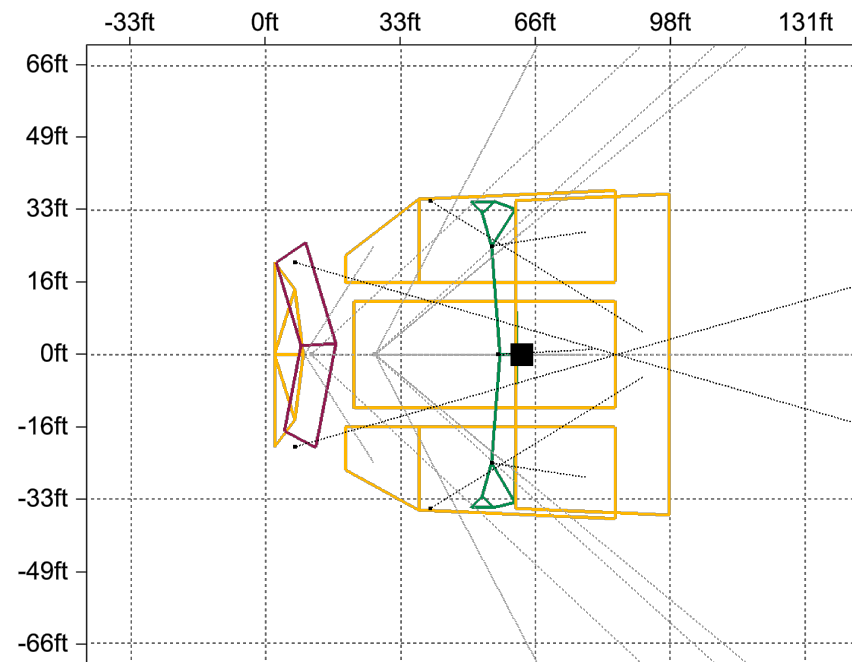

Test point ■ x: 62.3 ft y: 0.0 ft z: 7.5 ft

Arrival times

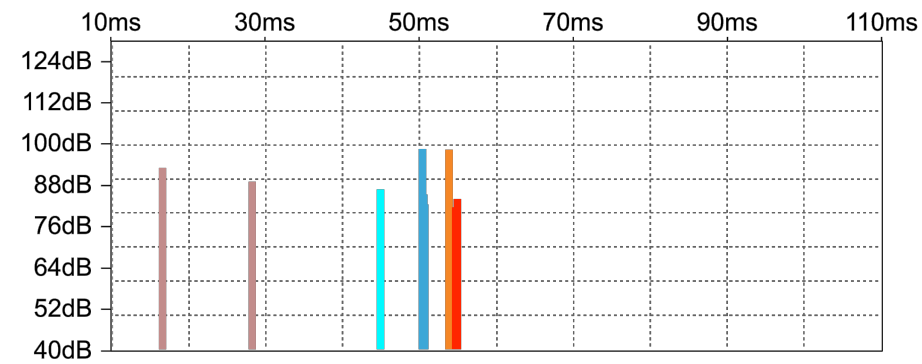

Array	Delay	Point source group
Main Array Y	0.3 ms	Under Balcs
Delay Array Q	12.7 ms	Balcony L/R C7
Delay Array Y	13.3 ms	Orchestra L/R C7
SUB array	8.6 ms	

Alignment SUB array

Main Array Y: Profile at 0° aiming

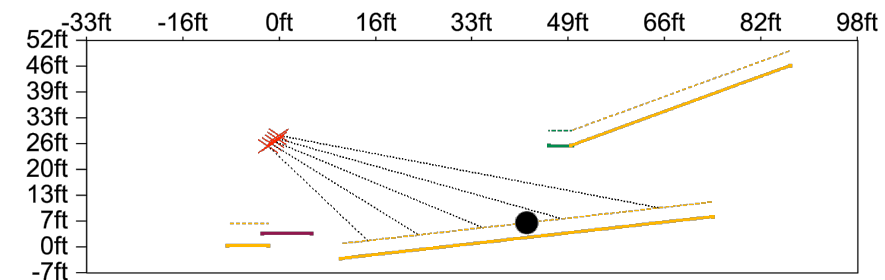

Test point ● x: 53.3 ft y: 0.0 ft z: 5.9 ft

Phase response (distance-compensated)

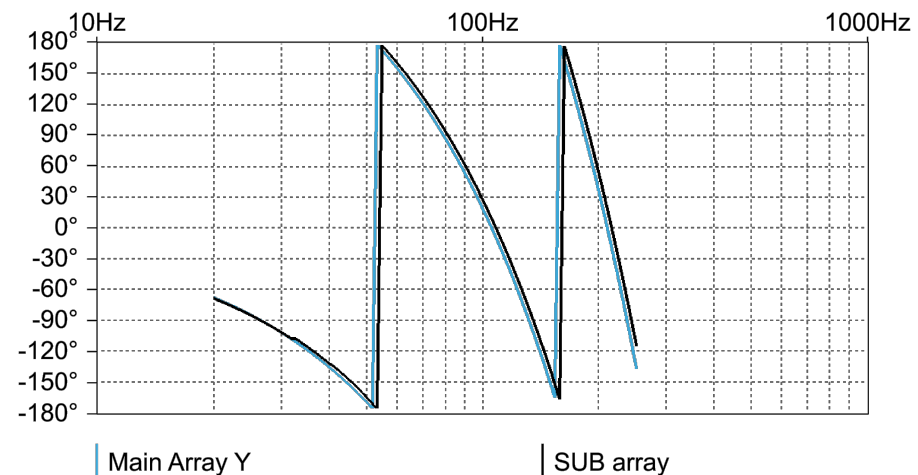

Tracy Cowit

Head Sound A1

Sound Designer
Drew Levy

Associate Sound Designer

Maria Wurttele

305.878.0893

wurttele.mf@artist.uncsa.edu

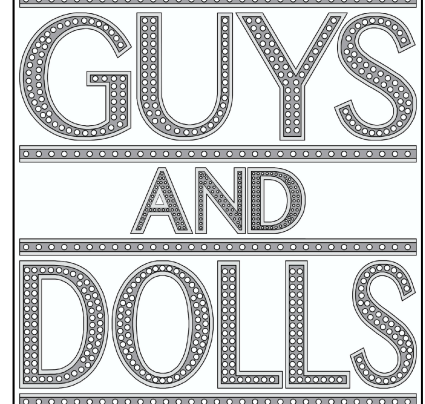

Venue

STEVENS CENTER

Producer

UNCSA

Director

GUS KAIKKONEN

Production Manager

DENNIS BOOTH

Scenic Designer

GARRET DAUB

Lighting Designer

AL CRAWFORD

Drawn By: Drew Levy/ Plated By: TAC

File Name: Guys and Dolls v2015.dwg

Drawing Date: 04/25/15

Load-In Date

20 MARCH, 2015

Load-Out Date

19 APRIL, 2015

ARRAY CALC
SYSTEM ALIGNMENT

Plate
9.2

Rigging plot

Main Array Y

Y-Series flown

Load OK

18% of load limit

Array data

Position x:	11.1 ft	Position y:	0.0 ft
Frame height front (z):	29.0 ft	Distance L/R:	0.0 ft
Horizontal aiming:	0.0 °	No. of Y-SUB	0
Frame angle:	-16.0 °	No. of Y8	5
Height of lowest edge:	25.36 ft	No. of Y12	0

Load

Load OK	18% of load limit
within BGV-C1 limits	
Rear pick:	168 lbs
Front pick:	97 lbs
Single pick:	265 lbs
Total weight:	265 lbs

Pickpoints

	Rear pick	Front pick	Distance	Single pick
X:	9.05 ft	11.01 ft	1.97 ft	9.80 ft
Y:	0.00 ft	0.00 ft	0.00 ft	0.00 ft
Pickpoint hole:	40	1		25.5
Position:				1.4 ft

Y Flying adapter pickpoints

Pickpoint hole:	19.5	Pickpoint pos.:	1.3 ft
-----------------	------	-----------------	--------

WARNING!

Always make sure that each of your hoists is able to carry the total weight of the array.

Array view

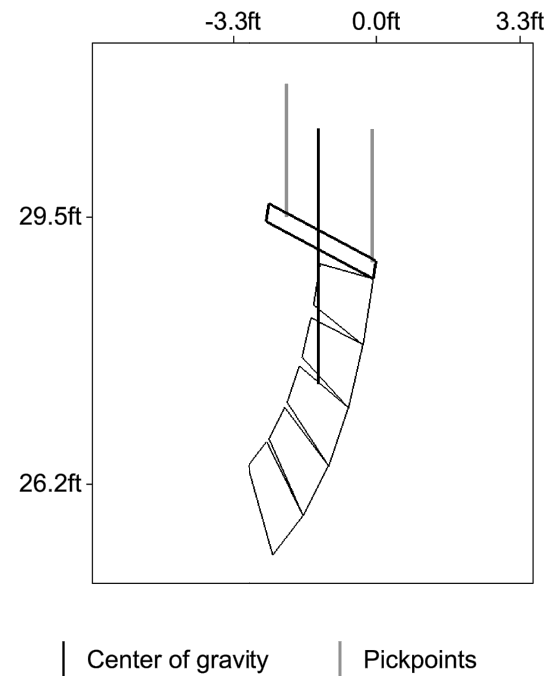

Frame details

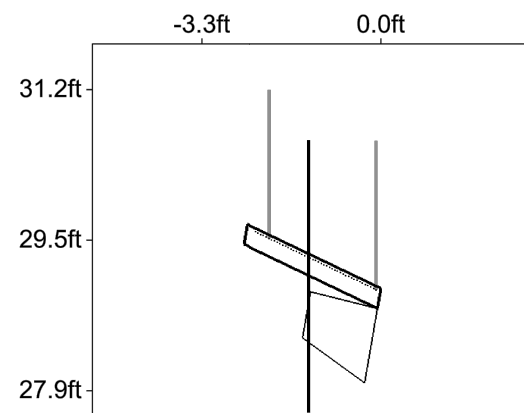

Required space (L)

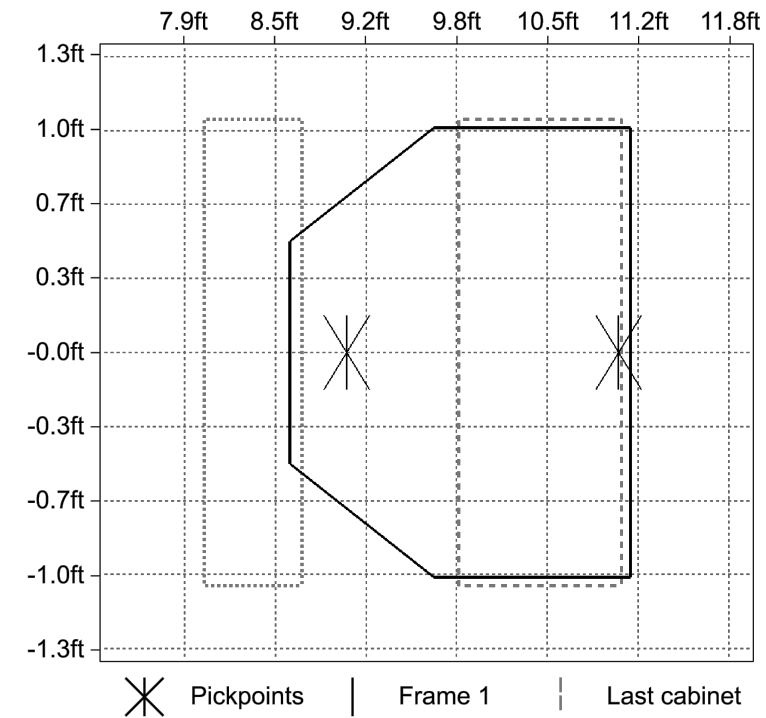

Tracy Cowit

Head Sound A1

Sound Designer
Drew Levy

Associate Sound Designer

Maria Wurttele

305.878.0893

wurttele.mf@artist.uncsa.edu

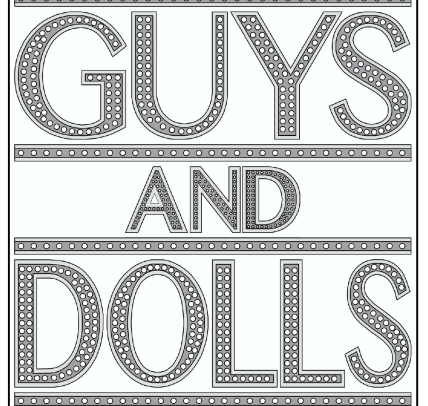

Venue

STEVENS CENTER

Producer

UNCSA

Director

GUS KAIKKONEN

Production Manager

DENNIS BOOTH

Scenic Designer

GARRET DAUB

Lighting Designer

AL CRAWFORD

Drawn By: Drew Levy/ Plated By: TAC

File Name: Guys and Dolls v2015.dwg

Drawing Date: 04/25/15

Load-In Date

20 MARCH, 2015

Load-Out Date

19 APRIL, 2015

ARRAY CALC
Y8 ARRAY RIGGING

Plate
9.3

Rigging plot **Delay Array Q** **Q-Series flown** **Load OK** **24% of load limit**

Array data

Position x:	26.5 ft	Position y:	0.0 ft
Frame height front (z):	42.0 ft	Distance L/R:	0.0 ft
Horizontal aiming:	0.0 °	No. of Q-SUB	0
Frame angle:	8.0 °	No. of Q1	5
Height of lowest edge:	36.72 ft	No. of Q7	0

Pickpoints

	Rear pick	Front pick	Distance	Single pick
X:	24.35 ft	26.47 ft	2.11 ft	25.98 ft
Y:	0.00 ft	0.00 ft	0.00 ft	0.00 ft
Pickpoint hole:	27	1		7.75
Position:				0.6 ft

Q Flying adapter pickpoints

Pickpoint hole:	---	Pickpoint pos.:	---
-----------------	-----	-----------------	-----

WARNING!

Always make sure that each of your hoists is able to carry the total weight of the array.

Load

Load OK	24% of load limit
within BGV-C1 limits	
Rear pick:	73 lbs
Front pick:	210 lbs
Single pick:	283 lbs
Total weight:	283 lbs

Array view

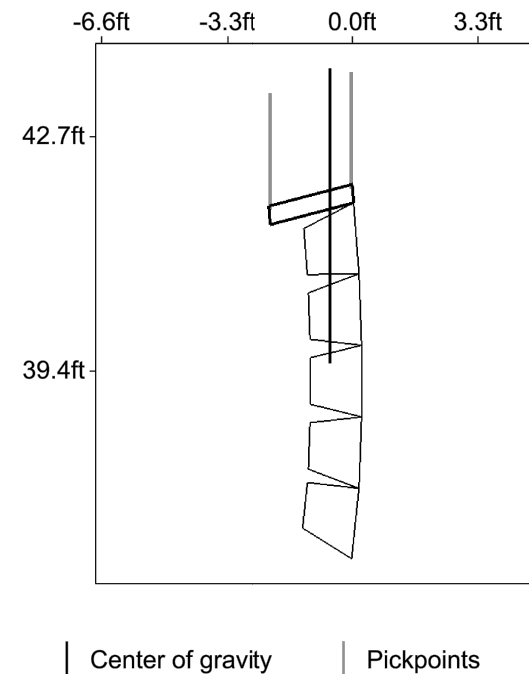

Frame details

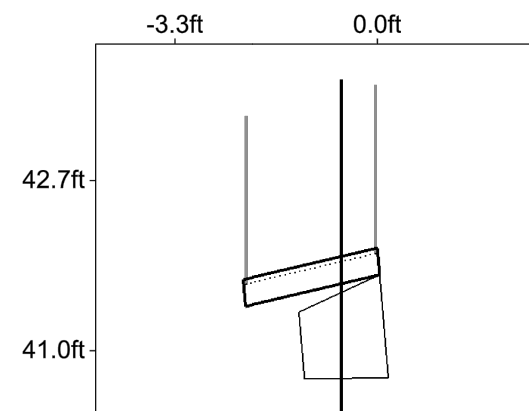

Required space (L)

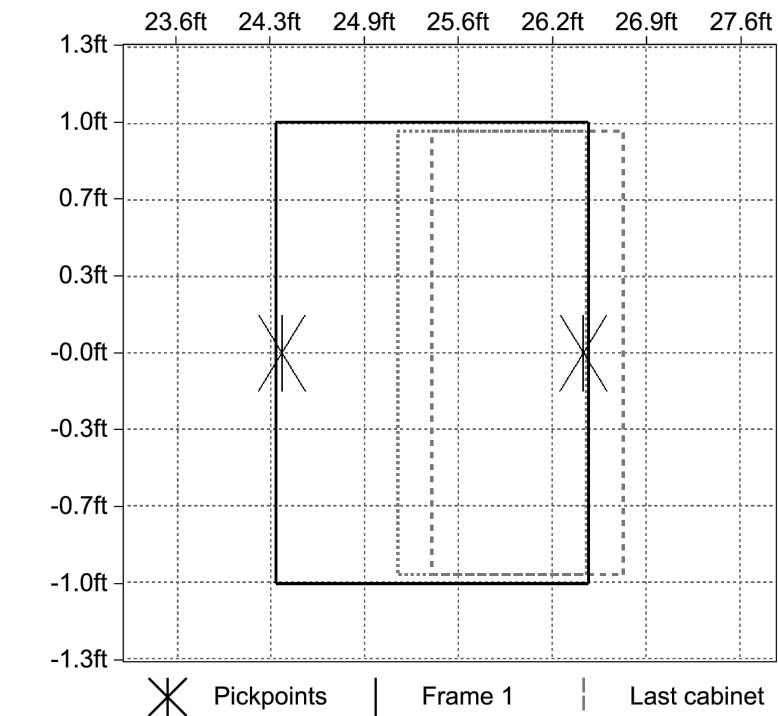

Tracy Cowit

Head Sound A1

Sound Designer
Drew Levy

Associate Sound Designer
Maria Wurttele
305.878.0893
wurttele.mf@artist.uncsa.edu

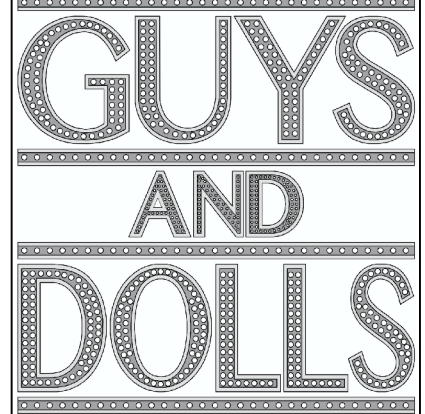

Venue
STEVENS CENTER

Producer
UNCSA

Director
GUS KAIKKONEN

Production Manager
DENNIS BOOTH

Scenic Designer
GARRET DAUB

Lighting Designer
AL CRAWFORD

Drawn By: Drew Levy/ Plated By: TAC
File Name: Guys and Dolls v2015.dwg
Drawing Date: 04/25/15

Load-In Date 20 MARCH, 2015	Load-Out Date 19 APRIL, 2015
--------------------------------	---------------------------------

ARRAY CALC
Q SERIES ARRAY RIGGING

Plate
9.4

Tracy Cowit

Head Sound A1

Sound Designer
Drew Levy

Associate Sound Designer
Maria Wurttele
305.878.0893
wurttele.mf@artist.uncsa.edu

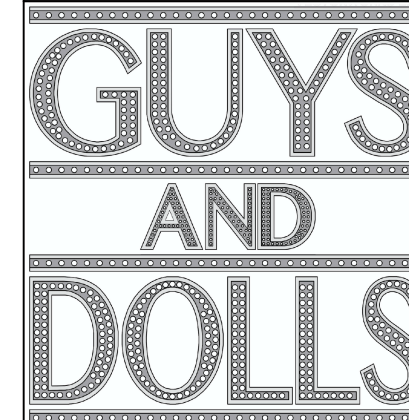

Venue
STEVENS CENTER

Producer
UNCSA

Director
GUS KAIKKONEN

Production Manager
DENNIS BOOTH

Scenic Designer
GARRET DAUB

Lighting Designer
AL CRAWFORD

Drawn By: Drew Levy/ Plated By: TAC
File Name: Guys and Dolls v2015.dwg
Drawing Date: 04/25/15

Load-In Date: 20 MARCH, 2015
Load-Out Date: 19 APRIL, 2015

**ARRAY CALC
PARTS LIST**

Plate
9.5

ArrayCalc V7.8 R004

Project: Guys & Dolls UNCSA

Date: 03.01.2015

Author: Drew Levy

Parts list							Total	
Arrays							SUB array	Additional LS
d&b part no.	Array 1 Main Arr... (single)	Array 2 Delay Ar... (single)	Array 3 Delay Ar... (single)					
Q-Series								
Q-SUB	Z0510							--
Q1	Z0501	5						5
Q7 (Rotate Horn!)	Z0507							--
Rigging parts:								
Q Flying frame	Z5159		1					1
Q Hoist connector chain	Z5155		2					2
1t shackles	Z6507		2					2
Locking pin sets 8mm	Z5153		20					20
Q Front links	Z5152		10					10
Q Splay links	Z5151		10					10
Y-Series								
Y-SUB	Z0709					2		2
Y8	Z0707	5		4				9
Y12	Z0708			1				1
Rigging parts:								
Y Flying frame	Z5380	1		1				2
Y Hoist connector chain	Z5381	2		2				4
Y Safety chainset 2 leg	Z5382	1		1				2
Amplifiers								
D12	Z2600	Chs	Chs	Chs		Chs	Chs	Amps
D6	Z2700							--
D80	Z2710	5	3	5		2		4



ArrayCalc V7.8 R004

Project: Guys & Dolls UNCSA

Date: 03.01.2015

Author: Drew Levy

Parts list						Total	
Point sources							
	d&b part no.	PSG 1 Under Balcs	PSG 2 Balcony L/R ...	PSG 3 Orchestra L/...			
Q-Series							
Q7 (as point source)	Z0507	3	2	2			7
Q10	Z0508						--
Amplifiers							
D12	Z2600	Chs	Chs	Chs			Amps
D6	Z2700						--
D80	Z2710	3	2	2			3



ArrayCalc V7.8 R004

Project: Guys & Dolls UNCSA

Date: 03.01.2015

Author: Drew Levy

Main Array Y - Patch

Total D80: 1

Total D12: 0

Total D6: 0

Cabinets		Left	Input type: Analog / Analog		Input source: 1	
Cab. Type	Link	Channel name	Device	Output mode	Ch.	ID
1	Y8	Main Arr 01	D80	Dual Channel / Dual Channel	A	0.01
2	Y8	Main Arr 02	D80	Dual Channel / Dual Channel	A	0.01
3	Y8	Main Arr 03	D80	Dual Channel / Dual Channel	A	0.01
4	Y8	Main Arr 04	D80	Dual Channel / Dual Channel	A	0.01
5	Y8	Main Arr 05	D80	Dual Channel / Dual Channel	A	0.01

Tracy Cowit

Head Sound A1

Sound Designer
Drew Levy

Associate Sound Designer
Maria Wurttele
305.878.0893
wurttele.mf@artist.uncsa.edu

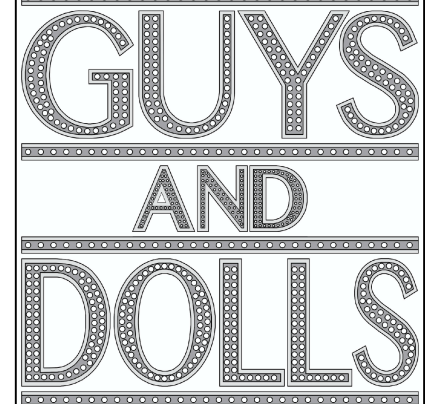

Venue
STEVENS CENTER

Producer
UNCSA

Director
GUS KAIKKONEN

Production Manager
DENNIS BOOTH

Scenic Designer
GARRET DAUB

Lighting Designer
AL CRAWFORD

Drawn By: Drew Levy/ Plated By: TAC
File Name: Guys and Dolls v2015.dwg
Drawing Date: 04/25/15

Load-In Date: 20 MARCH, 2015
Load-Out Date: 19 APRIL, 2015

ARRAY CALC
R1 Export- Main Y Array

Plate
9.6



ArrayCalc V7.8 R004

Project: Guys & Dolls UNCSA

Date: 03.01.2015

Author: Drew Levy

Delay Array Q - Patch **Total D80: 1** **Total D12: 0** **Total D6: 0**

Cabinets		Left	Input type: Digital master / Digital sla		Input source: 1	
Cab.	Type	Link	Channel name	Device	Output mode	Ch. ID
1	Q1		Delay Ar 01-02	D80	Dual Channel / Dual Channel	A 0.02
2	Q1	+				
3	Q1		Delay Ar 03-04	D80	Dual Channel / Dual Channel	B 0.02
4	Q1	+				
5	Q1		Delay Ar 05	D80	Dual Channel / Dual Channel	C 0.02

Tracy Cowit

Head Sound A1

Sound Designer
Drew Levy

Associate Sound Designer
Maria Wurttele

305.878.0893

wurttele.mf@artist.uncsa.edu

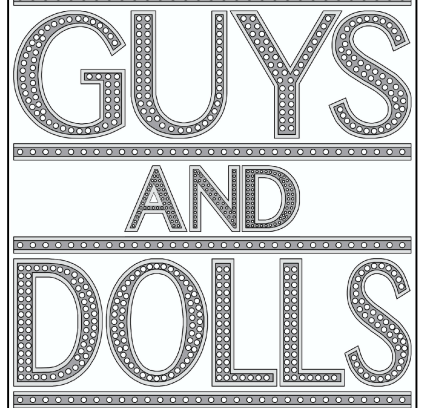

Venue
STEVENS CENTER

Producer
UNCSA

Director
GUS KAIKKONEN

Production Manager
DENNIS BOOTH

Scenic Designer
GARRET DAUB

Lighting Designer
AL CRAWFORD

Drawn By: Drew Levy/ Plated By: TAC
File Name: Guys and Dolls v2015.dwg
Drawing Date: 04/25/15

Load-In Date: 20 MARCH, 2015 | Load-Out Date: 19 APRIL, 2015

ARRAY CALC
R1 Export Delay Q Array

Plate
9.7



ArrayCalc V7.8 R004

Project: Guys & Dolls UNCSA

Date: 03.01.2015

Author: Drew Levy

Delay Array Y - Patch

Total D80: 1

Total D12: 0

Total D6: 0

Cabinets		Left	Input type: Analog / Analog		Input source: 1	
Cab.	Type	Link	Channel name	Device	Output mode	Ch. ID
1	Y8		Delay Ar 01	D80	Dual Channel / Dual Channel	A 0.01
2	Y8		Delay Ar 02	D80	Dual Channel / Dual Channel	A 0.01
3	Y8		Delay Ar 03	D80	Dual Channel / Dual Channel	A 0.01
4	Y8		Delay Ar 04	D80	Dual Channel / Dual Channel	A 0.01
5	Y12		Delay Ar 05	D80	Dual Channel / Dual Channel	A 0.01

Tracy Cowit

Head Sound A1

Sound Designer

Drew Levy

Associate Sound Designer

Maria Wurttele

305.878.0893

wurttele.mf@artist.uncsa.edu

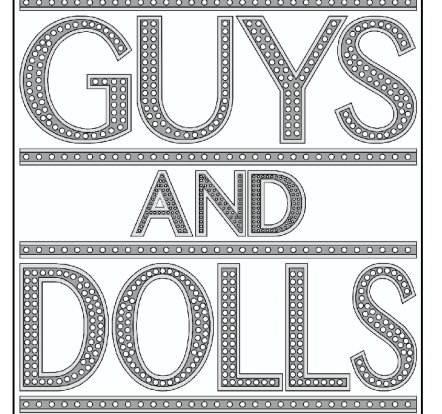

Venue

STEVENS CENTER

Producer

UNCSA

Director

GUS KAIKKONEN

Production Manager

DENNIS BOOTH

Scenic Designer

GARRET DAUB

Lighting Designer

AL CRAWFORD

Drawn By: Drew Levy/ Plated By: TAC

File Name: Guys and Dolls v2015.dwg

Drawing Date: 04/25/15

Load-In Date	Load-Out Date
20 MARCH, 2015	19 APRIL, 2015

ARRAY CALC

R1 Export Delay Array Y8

Plate
9.8



ArrayCalc V7.8 R004

Project: Guys & Dolls UNCSA

Date: 03.01.2015

Author: Drew Levy

Under Balcs - Patch **Total D80: 1** **Total D12: 0** **Total D6: 0**

Cab.	Type	Link	Channel name	Device	Input type	src.	Output mode	Ch.	ID
1	Q7-40x75		Under Ba 01	D80	Analog / Analog	1	Dual Channel / Dual Channel	A	0.01
2	Q7-40x75		Under Ba 02	D80	Analog / Analog	1	Dual Channel / Dual Channel	A	0.01
3	Q7-40x75		Under Ba 03	D80	Analog / Analog	1	Dual Channel / Dual Channel	A	0.01

Tracy Cowit

Head Sound A1

Sound Designer

Drew Levy

Associate Sound Designer

Maria Wurttele

305.878.0893

wurttele.mf@artist.uncsa.edu

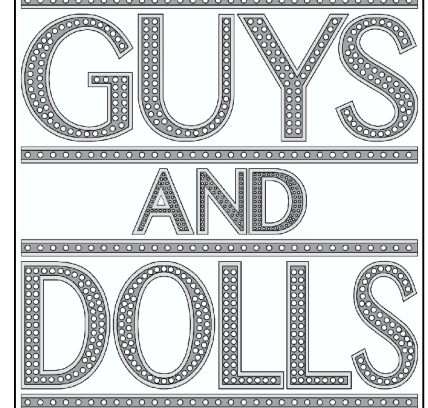

Venue

STEVENS CENTER

Producer

UNCSA

Director

GUS KAIKKONEN

Production Manager

DENNIS BOOTH

Scenic Designer

GARRET DAUB

Lighting Designer

AL CRAWFORD

Drawn By: Drew Levy/ Plated By: TAC

File Name: Guys and Dolls v2015.dwg

Drawing Date: 04/25/15

Load-In Date

20 MARCH, 2015

Load-Out Date

19 APRIL, 2015

ARRAY CALC

R1 Export Underbalcs

Plate
9.9



ArrayCalc V7.8 R004

Project: Guys & Dolls UNCSA

Date: 03.01.2015

Author: Drew Levy

Balcony L/R C7 - Patch

Total D80: 1

Total D12: 0

Total D6: 0

Cab. Type	Link	Channel name	Device	Input type	src.	Output mode	Ch.	ID
1	Q7-75x40	Point so 01	D80	Analog / Analog	1	Dual Channel / Dual Channel	A	0.01
2	Q7-75x40	Point so 02	D80	Analog / Analog	1	Dual Channel / Dual Channel	A	0.01

Tracy Cowit

Head Sound A1

Sound Designer
Drew Levy

Associate Sound Designer
Maria Wurttle
305.878.0893
wurttle.mf@artist.uncsa.edu

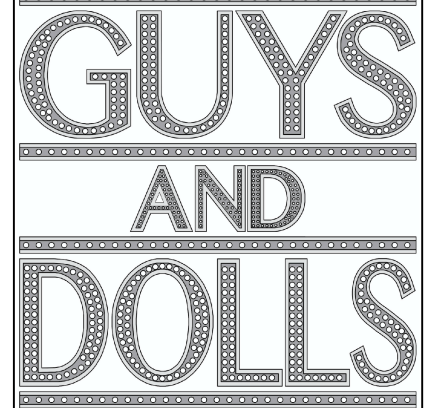

Venue
STEVENS CENTER

Producer
UNCSA

Director
GUS KAIKKONEN

Production Manager
DENNIS BOOTH

Scenic Designer
GARRET DAUB

Lighting Designer
AL CRAWFORD

Drawn By: Drew Levy/ Plated By: TAC
File Name: Guys and Dolls v2015.dwg
Drawing Date: 04/25/15

Load-In Date: 20 MARCH, 2015
Load-Out Date: 19 APRIL, 2015

ARRAY CALC
R1 Export Balc Fills

Plate
9.10



ArrayCalc V7.8 R004

Project: Guys & Dolls UNCSA

Date: 03.01.2015

Author: Drew Levy

Orchestra L/R C7 - Patch

Total D80: 1

Total D12: 0

Total D6: 0

Cab. Type	Link	Channel nam	Device	Input type	src.	Output mode	Ch.	ID
1	Q7-75x40	Point so 01	D80	Analog / Analog	1	Dual Channel / Dual Channel	A	0.01
2	Q7-75x40	Point so 02	D80	Analog / Analog	1	Dual Channel / Dual Channel	A	0.01

Tracy Cowit

Head Sound A1

Sound Designer
Drew Levy

Associate Sound Designer
Maria Wurtele

305.878.0893

wurtele.mf@artist.uncsa.edu

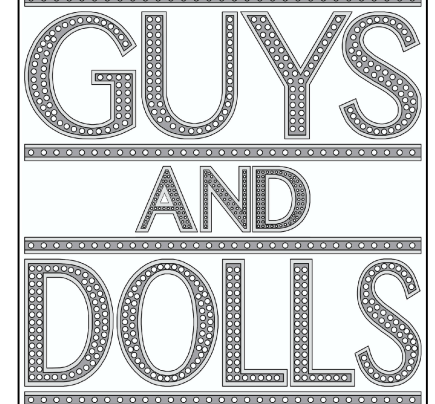

Venue

STEVENS CENTER

Producer

UNCSA

Director

GUS KAIKKONEN

Production Manager

DENNIS BOOTH

Scenic Designer

GARRET DAUB

Lighting Designer

AL CRAWFORD

Drawn By: Drew Levy/ Plated By: TAC
File Name: Guys and Dolls v2015.dwg
Drawing Date: 04/25/15

Load-In Date	Load-Out Date
20 MARCH, 2015	19 APRIL, 2015

ARRAY CALC
R1 Export Front Fills

Plate
9.11



ArrayCalc V7.8 R004

Project: Guys & Dolls UNCSA

Date: 03.01.2015

Author: Drew Levy

SUB array - Patch **Total D80: 1** **Total D12: 0** **Total D6: 0**

R1

Cab.	Type	Link	Channel name	Device	Input type	src.	Output mode	Ch.	ID
1	Y-SUB		SUB array R01-01	D80	Digital master / Digital slave	1	2-Way Active / Dual Channel	C	0.13

L1

Cab.	Type	Link	Channel name	Device	Input type	src.	Output mode	Ch.	ID
1	Y-SUB		SUB array L01-01	D80	Digital master / Digital slave	1	2-Way Active / Dual Channel	C	0.13

Tracy Cowit

Head Sound A1

Sound Designer
Drew Levy

Associate Sound Designer
Maria Wurttele

305.878.0893

wurttele.mf@artist.uncsa.edu

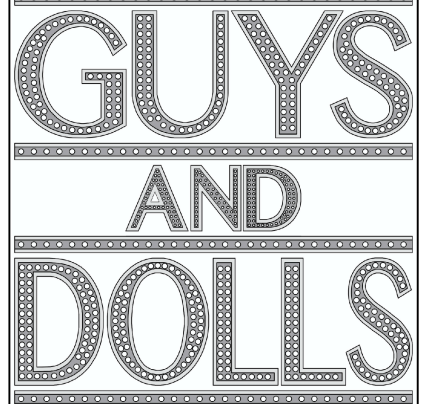

Venue

STEVENS CENTER

Producer

UNCSA

Director

GUS KAIKKONEN

Production Manager

DENNIS BOOTH

Scenic Designer

GARRET DAUB

Lighting Designer

AL CRAWFORD

Drawn By: Drew Levy/ Plated By: TAC

File Name: Guys and Dolls v2015.dwg

Drawing Date: 04/25/15

Load-In Date

20 MARCH, 2015

Load-Out Date

19 APRIL, 2015

ARRAY CALC

R1 Export Subs

Plate
9.12



Pickpoints

Main Array Y	Rear pick	Front pick	Distance	Single pick	
X:	9.05 ft	11.01 ft	1.97 ft	9.80 ft	Height of lowest edge
Y:	0.00 ft	0.00 ft	0.00 ft	0.00 ft	25.36 ft
Pickpoint hole:	40	1		25.5	
Load:	168 lbs	97 lbs	(Total:)	265 lbs	Load OK

Delay Array Q	Rear pick	Front pick	Distance	Single pick	
X:	24.35 ft	26.47 ft	2.11 ft	25.98 ft	Height of lowest edge
Y:	0.00 ft	0.00 ft	0.00 ft	0.00 ft	36.72 ft
Pickpoint hole:	27	1		7.75	
Load:	73 lbs	210 lbs	(Total:)	283 lbs	Load OK

Delay Array Y	Rear pick	Front pick	Distance	Single pick	
X:	25.08 ft	26.43 ft	1.35 ft	26.06 ft	Height of lowest edge
Y:	0.00 ft	0.00 ft	0.00 ft	0.00 ft	37.57 ft
Pickpoint hole:	27	1		8.5	
Load:	76 lbs	189 lbs	(Total:)	265 lbs	Load OK

WARNING!

Always make sure that each of your hoists is able to carry the total weight of the array.

Tracy Cowit

Head Sound A1

Sound Designer
Drew Levy

Associate Sound Designer

Maria Wurttele

305.878.0893

wurttele.mf@artist.uncsa.edu

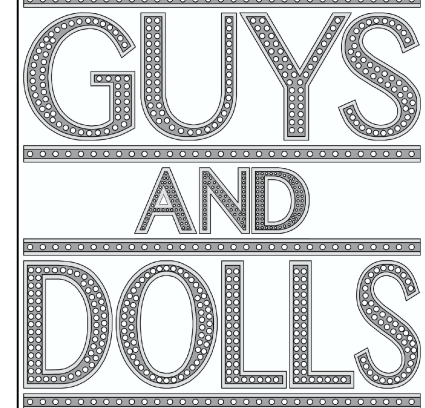

Venue

STEVENS CENTER

Producer

UNCSA

Director

GUS KAIKKONEN

Production Manager

DENNIS BOOTH

Scenic Designer

GARRET DAUB

Lighting Designer

AL CRAWFORD

Drawn By: Drew Levy/ Plated By: TAC
File Name: Guys and Dolls v2015.dwg
Drawing Date: 04/25/15

Load-In Date 20 MARCH, 2015	Load-Out Date 19 APRIL, 2015
--------------------------------	---------------------------------

ARRAY CALC
RIGGING PLOT ALL ARRAY

Plate
9.13



Cabinet layout

Under Balcs

Cat	x/m	y/m	z/m	Horizontal	Vertical	Rotation
1	16.8	7.5	7.3	8 °	-30 °	90 °
2	17.2	0.0	7.3	3 °	-30 °	90 °
3	16.8	-7.5	7.3	-8 °	-30 °	-90 °

Balcony L/R C7

Cat	x/m	y/m	z/m	Horizontal	Vertical	Rotation
1	12.2	10.7	10.4	-30 °	12 °	0 °
2	12.2	-10.7	10.4	30 °	12 °	0 °

Orchestra L/R C7

Cat	x/m	y/m	z/m	Horizontal	Vertical	Rotation
1	2.1	6.4	3.7	-15 °	0 °	0 °
2	2.1	-6.4	3.7	15 °	0 °	0 °

Tracy Cowit

Head Sound A1

Sound Designer

Drew Levy

Associate Sound Designer

Maria Wurttele

305.878.0893

wurttele.mf@artist.uncsa.edu

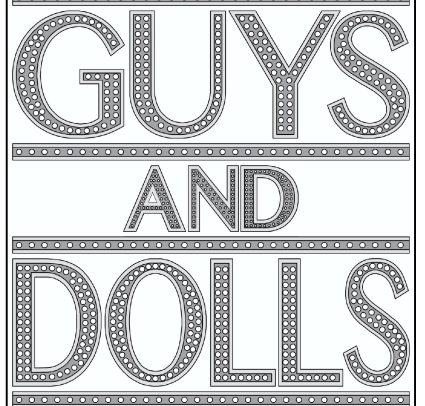

Venue

STEVENS CENTER

Producer

UNCSA

Director

GUS KAIKKONEN

Production Manager

DENNIS BOOTH

Scenic Designer

GARRET DAUB

Lighting Designer

AL CRAWFORD

Drawn By: Drew Levy/ Plated By: TAC

File Name: Guys and Dolls v2015.dwg

Drawing Date: 04/25/15

Load-In Date

20 MARCH, 2015

Load-Out Date

19 APRIL, 2015

ARRAY CALC
RIGGING PLOT ALL ARRAY

Plate
9.14



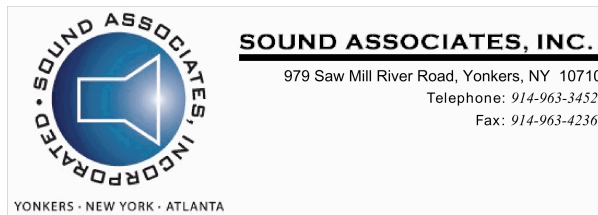

Quote

Page: Page 1 of 2
Job Reference: JOB28589YO



Quote

Page: Page 2 of 2
Job Reference: JOB28589YO

Client: UNIVERSITY OF NORTH CAROLINA SCHOOL OF THE ARTS Contact:
1533 SOUTH MAIN STREET Quote Date: Tuesday, March 10, 2015
DESIGN & PRODUCTION
JASON ROMNEY
WINSTON-SALEM NC 27127
Job Title: GUYS & DOLLS NORTH CAROLINA SCHOOL OF ARTS
General Job Dates: Sunday, March 15, 2015 to Tuesday, April 21, 2015

Thank you for giving me the opportunity to send you this quotation. Enclosed are the specifications as requested. If you have any questions do not hesitate to call me.

Rental Details

Equipment Ref: JOB28589YOEQ01YO Prep: 03/11/2015 @12:00 am
Venue: UNIVERSITY OF NORTH CAROLINA SCHOO Out: 03/16/2015 @ 9:00 am
Title: GUYS & DOLLS NORTH CAROLINA SCHOOL Show:
Transportation: We Deliver, We Pickup Back: 04/20/2015 @ 9:00 am
Check In: 04/21/2015 @12:00 am

Qty	Description	Total
GENERAL		
1	RENTAL AND TRUCKING	\$25,000.00
AUDIO		
3	CROWN PCC 160; MIC - BOUNDARY HEMI PATTERN	
2	DPA 4099; CLIP MICROPHONE FOR INSTRUMENTS	
2	DPA CC4099; CELLO MOUNT FOR 4099	
1	EARTHWORKS PM40T; PIANO MIC, TOURING MODEL	
19	NEUMANN KM184; MICROPHONE- CARDIOID- CONDENSER	
1	RADIAL JDI DUPLEX DI; DIRECT BOX DUPLEX ACTIVE	
5	SENNHEISER MKH800-P48; MIC MULTI PATTERN 5-WAY	
1	SHURE BETA 91A; MIC CARDIOID FOR DRUM	
4	SHURE BETA 98D/S; MICROPHONE DRUM KIT	
3	ATLAS GN-13E; MIC GOOSENECK 13" EBONY	
5	ATLAS MS-25E; MIC STAND/TRIANGLE BASE/EBONY	
4	LP LP592; MIC CLAW/MIC MOUNT FOR DRUMS	
4	DIGICO AES OUT CARD; OUTPUT CARD DIGITAL 8 X MONO	
6	DIGICO ANALOGUE OUTPUT CARD; CARD FOR DIGICO	
2	DIGICO LOCAL RACK; R/F 2-PSU 2MADI PORTS	
14	DIGICO MIC/LINE INPUT CARD; CARD INPUT FOR DIGICO	
1	DIGICO SD10-36-T; DIGITAL CONSOLE W/ T SOFTWARE	
1	TC ELEC S6000 RCP; SYSTEM 6000 PRECESSOR RMT CPU	
1	TC ELEC S6000ICN; SYSTEM 6000 PROCESSOR ICON	
1	TC ELEC S6000MF; REVERB 6000 MAINFRAME DIGITAL	
14	D&B D12-NL4; AMPLIFIER 2 CHANNEL 750W/CH (NL4 OUT)	
4	D&B C7-TOP; SPEAKER FULL RANGE 75x40	
7	D&B E8; SPEAKER NL4	
3	CROWN D6640-3; CABLE FOR PCC-160 MIC	
RIGGING		

- 4 D&B C7-D YOKE; YOKE FOR D&B C7
7 D&B Z5351; BRACKET HORIZONTAL FOR E8
CABLE
- 1 SAI CABLE PACKAGE; SEE NOTE BELOW
1X 10' 4PR XLR SNAKE
1X 10' 9PR WITH TAILS
1X 10' 12PR WITH TAILS
3X 15' 4PR XLR SNAKE
7X 15' 9PR WITH TAILS
1X 15' 12PR WITH TAILS
1X 25' 6PR WITH TAILS
2X 25' 12PR WITH TAILS
1X 50' 4PR XLR SNAKE
2X 50' 9PR WITH TAILS
1X 50' 24PR WITH STAGE BOX AND MALE TAILS (USE ANY COMBINATION OF CABLES BUNDLED TO MAKE THIS)

- NL8:
1X 50'
3X 100'
2X 150'
1X 200'
14X NL8 TO 4 NL2 BREAKOUTS
- 4 MADI CABLE 100M; CABLE MADI 100M
MISCELLANEOUS
- 1 DIGICO GPIO BREAKOUT FOR SD10
1 SAI RF LISTENING SYSTEM W/ 2 REMOTES

Equipment Total: **\$25,000.00**

Summary of Totals

Equipment Subtotal: **\$25,000.00**
Tax: **\$0.00**
Grand Total: **\$25,000.00**

I hope that this is to your satisfaction. Again, thank you, and I look forward to speaking with you.

Yours Sincerely

Greg Reif

Tracy Cowit

Head Sound A1

Sound Designer
Drew Levy

Associate Sound Designer
Maria Wurttele
305.878.0893
wurttele.mf@artist.uncsa.edu

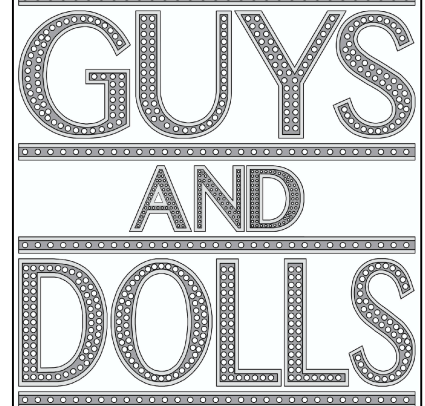

Venue
STEVENS CENTER

Producer
UNCSA

Director
GUS KAIKKONEN

Production Manager
DENNIS BOOTH

Scenic Designer
GARRET DAUB

Lighting Designer
AL CRAWFORD

Drawn By: TAC
File Name: Guys and Dolls v2015.dwg
Drawing Date: 04/25/15

Load-In Date: 20 MARCH, 2015 Load-Out Date: 19 APRIL, 2015

**SOUND ASSOCIATES
BID DOCUMENT**

Plate
10.1

Reference ID: UNSA031215		EQUIPMENT PULL LIST		d&b audiotechnik	
Code: 010-SUPPORT		Ship Date : 3/16/15			
Shipping To: UNCSA		Delivery or Need By Date: 03/16/15		Client Pick Up	
Attn: Jason Romney		Shipping Method:			
4828 Lighthouse Ct. Winston-Salem, NC 27127 (366) 734-2937		Special Instructions:			
		Expected Return Date: 04/23/15			

QTY	Item #	Description	Serial Number	Pull Notes / Location	Chk'd By?	Returned?
6	Z0707.002	Y8 loudspeaker NLT4F/M				
1	Z5390.000	Y flying frame w/ (2) lifting chains				
1		Y 4 x cart				
1		2 or 4 x Y case?				
1		Y flying frame case				
3		Y series NL4TF/M jumpers				
2	Z0620.001	E8 loudspeaker, NL4				
2	Z5350.000	E8 flying bracket				
1	E7446.000	2 x E8 touring case				
2	Z2600.000	D6 amplifier				
1	A4104.001	Q7 loudspeaker, NL4		SO8610		
1	Z0501.001	Q1 loudspeaker, NL4		SO8610		
<i>Potential Purchase Items:</i>						
9	Z0450.000	E5 loudspeaker, NL4		SO8610		
9	Z5356.000	E4/E5 ball joint adapter		SO8610		
1	Z0620.001	E8 loudspeaker, NL4		SO8610		
1	Z5351.000	E8 horizontal bracket		SO8610		
3	Z5175.000	Qi horizontal bracket - C stock		SO8610		

Demo / Loan Conditions:

We the undersigned agree to accept this equipment as is and accept full responsibility for its well being while in our possession. This equipment will not be used or transported to any space beyond the ship to address or by anyone except representatives of UNCSA. All equipment and packaging will be preserved and handled so an "As New" return is ensured. We accept responsibility for any damage that may occur while in our possession and agree to pay required repair or replacement charges. We also agree that it is our responsibility, at our expense, to return the equipment by the date specified above. If any equipment will not be returned as promised on or by the date specified above, we will communicate with d&b audiotechnik 5 days prior to the return date for revised arrangements.

Signature: _____ Date: _____

Printed Name: _____

Tracy Cowit

Head Sound A1

Sound Designer

Drew Levy

Associate Sound Designer

Maria Wurttele

305.878.0893

wurttele.mf@artist.uncsa.edu

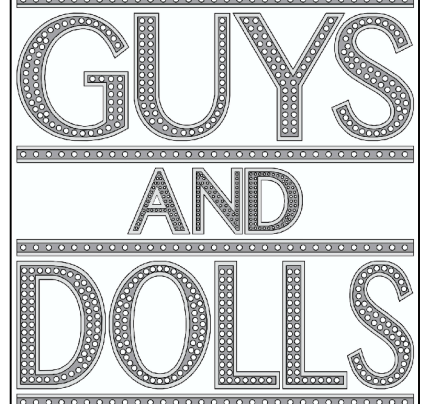

Venue

STEVENS CENTER

Producer

UNCSA

Director

GUS KAIKKONEN

Production Manager

DENNIS BOOTH

Scenic Designer

GARRET DAUB

Lighting Designer

AL CRAWFORD

Drawn By: TAC

File Name: Guys and Dolls v2015.dwg

Drawing Date: 04/25/15

Load-In Date

20 MARCH, 2015

Load-Out Date

19 APRIL, 2015

D&B LOAN/ BID

DOCUMENT

Plate
10.2

Tracy Cowit Time Sheet

Date			8:00am	9:00am	10:00am	11:00am	12:00pm	1:00pm	2:00pm	3:00pm	4:00pm	5:00pm	6:00pm	7:00pm	8:00pm	9:00pm	10:00pm	11:00pm	12:00am	Total	
Sunday	March 01	Estimated																		Estimated	0
		Actual																		Actual	0
Monday	March 02	Estimated																		Estimated	4
		Actual																		Actual	4
Tuesday	March 03	Estimated																		Estimated	4
		Actual																		Actual	4
Wednesday	March 04	Estimated																		Estimated	8
		Actual																		Actual	8
Thursday	March 05	Estimated																		Estimated	0
		Actual																		Actual	4
Friday	March 06	Estimated																		Estimated	4
		Actual																		Actual	4
Saturday	March 07	Estimated																		Estimated	0
		Actual																		Actual	0
																				Estimated Total	20
																				Actual Total	24

Date			8:00am	9:00am	10:00am	11:00am	12:00pm	1:00pm	2:00pm	3:00pm	4:00pm	5:00pm	6:00pm	7:00pm	8:00pm	9:00pm	10:00pm	11:00pm	12:00am	Total	
Sunday	March 08	Estimated																		Estimated	0
		Actual																		Actual	0
Monday	March 09	Estimated																		Estimated	0
		Actual																		Actual	0
Tuesday	March 10	Estimated																		Estimated	0
		Actual																		Actual	0
Wednesday	March 11	Estimated																		Estimated	0
		Actual																		Actual	0
Thursday	March 12	Estimated																		Estimated	0
		Actual																		Actual	0
Friday	March 13	Estimated																		Estimated	0
		Actual																		Actual	0
Saturday	March 14	Estimated																		Estimated	0
		Actual																		Actual	0
																				Estimated Total	0
																				Actual Total	0

Tracy Cowit

Head Sound A1

Sound Designer
Drew Levy

Associate Sound Designer
Maria Wurttele

305.878.0893

wurttele.mf@artist.uncsa.edu

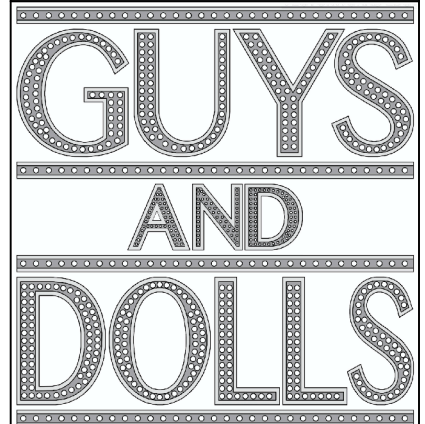

Venue

STEVENS CENTER

Producer

UNCSA

Director

GUS KAIKKONEN

Production Manager

DENNIS BOOTH

Scenic Designer

GARRET DAUB

Lighting Designer

AL CRAWFORD

Drawn By: GTS & TAC

File Name: Guys and Dolls v2015.dwg

Drawing Date: 04/25/15

Load-In Date

20 MARCH, 2015

Load-Out Date

19 APRIL, 2015

TIME SHEET - TRACY

Plate
11.1

Tracy Cowit Time Sheet

Date		8:00am	9:00am	10:00am	11:00am	12:00pm	1:00pm	2:00pm	3:00pm	4:00pm	5:00pm	6:00pm	7:00pm	8:00pm	9:00pm	10:00pm	11:00pm	12:00am	Total		
Sunday	March 15	Estimated																		Estimated	0
		Actual																		Actual	0
Monday	March 16	Estimated																		Estimated	8
		Actual																		Actual	8
Tuesday	March 17	Estimated																		Estimated	4
		Actual																		Actual	4
Wednesday	March 18	Estimated																		Estimated	8
		Actual																		Actual	8
Thursday	March 19	Estimated																		Estimated	4
		Actual																		Actual	4
Friday	March 20	Estimated																		Estimated	10
		Actual																		Actual	10
Saturday	March 21	Estimated																		Estimated	8
		Actual																		Actual	8
		Estimated Total																		42	
		Actual Total																		42	

Date		8:00am	9:00am	10:00am	11:00am	12:00pm	1:00pm	2:00pm	3:00pm	4:00pm	5:00pm	6:00pm	7:00pm	8:00pm	9:00pm	10:00pm	11:00pm	12:00am	Total		
Sunday	March 22	Estimated																		Estimated	0
		Actual																		Actual	0
Monday	March 23	Estimated																		Estimated	8
		Actual																		Actual	8
Tuesday	March 24	Estimated																		Estimated	4
		Actual																		Actual	4
Wednesday	March 25	Estimated																		Estimated	8
		Actual																		Actual	8
Thursday	March 26	Estimated																		Estimated	4
		Actual																		Actual	4
Friday	March 27	Estimated																		Estimated	12
		Actual																		Actual	12
Saturday	March 28	Estimated																		Estimated	9
		Actual																		Actual	9
		Estimated Total																		45	
		Actual Total																		45	

Tracy Cowit

Head Sound A1

Sound Designer
Drew Levy

Associate Sound Designer
Maria Wurttele
305.878.0893
wurttele.mf@artist.uncsa.edu

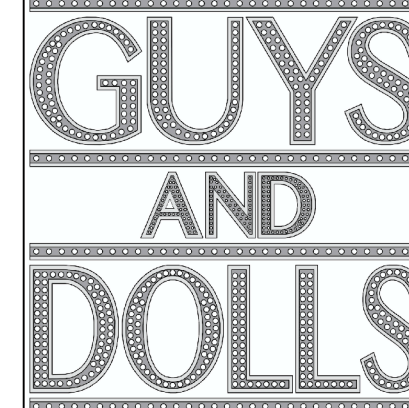

Venue
STEVENS CENTER

Producer
UNCSA

Director
GUS KAIKKONEN

Production Manager
DENNIS BOOTH

Scenic Designer
GARRET DAUB

Lighting Designer
AL CRAWFORD

Drawn By: GTS & TAC
File Name: Guys and Dolls v2015.dwg
Drawing Date: 04/25/15

Load-In Date: 20 MARCH, 2015
Load-Out Date: 19 APRIL, 2015

TIME SHEET - TRACY

Plate
11.2

Tracy Cowit Time Sheet

Date			8:00am	9:00am	10:00am	11:00am	12:00pm	1:00pm	2:00pm	3:00pm	4:00pm	5:00pm	6:00pm	7:00pm	8:00pm	9:00pm	10:00pm	11:00pm	12:00am	Total		
Sunday	March 29	Estimated		[Red bar from 9:00am to 11:00pm]																Estimated	15	
		Actual		[Red bar from 9:00am to 12:00am]																Actual	16	
Monday	March 30	Estimated																			Estimated	8.5
		Actual																				Actual
Tuesday	March 31	Estimated																		Estimated	0	
		Actual																		Actual	0	
Wednesday	April 01	Estimated																			Estimated	8
		Actual																				Actual
Thursday	April 02	Estimated																			Estimated	5
		Actual																				Actual
Friday	April 03	Estimated																			Estimated	8.5
		Actual																				Actual
Saturday	April 04	Estimated																			Estimated	14
		Actual																				Actual
																			Estimated Total	59		
																			Actual Total	66		

Date			8:00am	9:00am	10:00am	11:00am	12:00pm	1:00pm	2:00pm	3:00pm	4:00pm	5:00pm	6:00pm	7:00pm	8:00pm	9:00pm	10:00pm	11:00pm	12:00am	Total		
Sunday	April 05	Estimated																		Estimated	0	
		Actual																		Actual	0	
Monday	April 06	Estimated																			Estimated	8
		Actual																				Actual
Tuesday	April 07	Estimated																			Estimated	6
		Actual																				Actual
Wednesday	April 08	Estimated																			Estimated	8
		Actual																				Actual
Thursday	April 09	Estimated																			Estimated	5.5
		Actual																				Actual
Friday	April 10	Estimated																			Estimated	5.5
		Actual																				Actual
Saturday	April 11	Estimated																			Estimated	5
		Actual																				Actual
																			Estimated Total	38		
																			Actual Total	41		

Tracy Cowit

Head Sound A1

Sound Designer
Drew Levy

Associate Sound Designer
Maria Wurttele

305.878.0893

wurttele.mf@artist.unca.edu

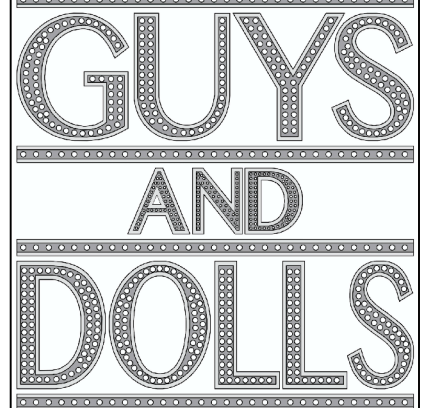

Venue

STEVENS CENTER

Producer

UNCSA

Director

GUS KAIKKONEN

Production Manager

DENNIS BOOTH

Scenic Designer

GARRET DAUB

Lighting Designer

AL CRAWFORD

Drawn By: GTS & TAC

File Name: Guys and Dolls v2015.dwg

Drawing Date: 04/25/15

Load-In Date

20 MARCH, 2015

Load-Out Date

19 APRIL, 2015

TIME SHEET - TRACY

Plate
11.3

Tracy Cowit Time Sheet

Date			8:00am	9:00am	10:00am	11:00am	12:00pm	1:00pm	2:00pm	3:00pm	4:00pm	5:00pm	6:00pm	7:00pm	8:00pm	9:00pm	10:00pm	11:00pm	12:00am	Total		
Sunday	April 12	Estimated																			Estimated	5
		Actual																			Actual	5
Monday	April 13	Estimated																			Estimated	0
		Actual																			Actual	0
Tuesday	April 14	Estimated																			Estimated	0
		Actual																			Actual	0
Wednesday	April 15	Estimated																			Estimated	6
		Actual																			Actual	6
Thursday	April 16	Estimated																			Estimated	6
		Actual																			Actual	6
Friday	April 17	Estimated																			Estimated	6
		Actual																			Actual	6
Saturday	April 18	Estimated																			Estimated	11
		Actual																			Actual	11
																				Estimated Total	34	
																				Actual Total	34	

Date			8:00am	9:00am	10:00am	11:00am	12:00pm	1:00pm	2:00pm	3:00pm	4:00pm	5:00pm	6:00pm	7:00pm	8:00pm	9:00pm	10:00pm	11:00pm	12:00am	Total		
Sunday	April 19	Estimated																			Estimated	9
		Actual																			Actual	9.5
Monday	April 20	Estimated																			Estimated	8
		Actual																			Actual	8
Tuesday	April 21	Estimated																			Estimated	4
		Actual																			Actual	4
Wednesday	April 22	Estimated																			Estimated	0
		Actual																			Actual	0
Thursday	April 23	Estimated																			Estimated	0
		Actual																			Actual	0
Friday	April 24	Estimated																			Estimated	0
		Actual																			Actual	0
Saturday	April 25	Estimated																			Estimated	0
		Actual																			Actual	0
																				Estimated Total	21	
																				Actual Total	22	

Tracy Cowit

Head Sound A1

Sound Designer
Drew Levy

Associate Sound Designer
Maria Wurttele

305.878.0893

wurttele.mf@artist.uncsa.edu

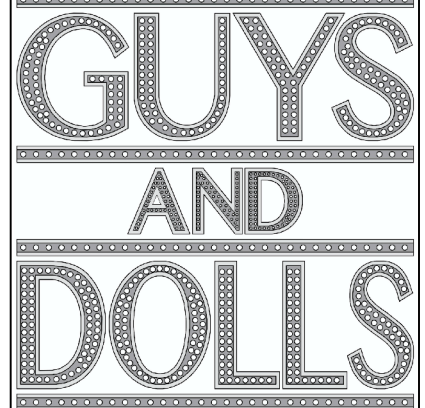

Venue

STEVENS CENTER

Producer

UNCSA

Director

GUS KAIKKONEN

Production Manager

DENNIS BOOTH

Scenic Designer

GARRET DAUB

Lighting Designer

AL CRAWFORD

Drawn By: GTS & TAC

File Name: Guys and Dolls v2015.dwg

Drawing Date: 04/25/15

Load-In Date

20 MARCH, 2015

Load-Out Date

19 APRIL, 2015

TIME SHEET - TRACY

Plate
11.4

Graham Schwartz Time Sheet

Date			8:00am	9:00am	10:00am	11:00am	12:00pm	1:00pm	2:00pm	3:00pm	4:00pm	5:00pm	6:00pm	7:00pm	8:00pm	9:00pm	10:00pm	11:00pm	12:00am	Total		
Sunday	March 01	Estimated																			Estimated	0
		Actual																			Actual	0
Monday	March 02	Estimated																			Estimated	4
		Actual																			Actual	4
Tuesday	March 03	Estimated																			Estimated	4
		Actual																			Actual	4
Wednesday	March 04	Estimated																			Estimated	8
		Actual																			Actual	8
Thursday	March 05	Estimated																			Estimated	0
		Actual																			Actual	4
Friday	March 06	Estimated																			Estimated	4
		Actual																			Actual	4
Saturday	March 07	Estimated																			Estimated	0
		Actual																			Actual	0
																				Estimated Total	20	
																				Actual Total	24	

Date			8:00am	9:00am	10:00am	11:00am	12:00pm	1:00pm	2:00pm	3:00pm	4:00pm	5:00pm	6:00pm	7:00pm	8:00pm	9:00pm	10:00pm	11:00pm	12:00am	Total		
Sunday	March 08	Estimated																			Estimated	0
		Actual																			Actual	0
Monday	March 09	Estimated																			Estimated	0
		Actual																			Actual	0
Tuesday	March 10	Estimated																			Estimated	0
		Actual																			Actual	0
Wednesday	March 11	Estimated																			Estimated	0
		Actual																			Actual	0
Thursday	March 12	Estimated																			Estimated	0
		Actual																			Actual	0
Friday	March 13	Estimated																			Estimated	0
		Actual																			Actual	0
Saturday	March 14	Estimated																			Estimated	0
		Actual																			Actual	0
																				Estimated Total	0	
																				Actual Total	0	

Tracy Cowit

Head Sound A1

Sound Designer

Drew Levy

Associate Sound Designer

Maria Wurttele

305.878.0893

wurttele.mf@artist.uncsa.edu

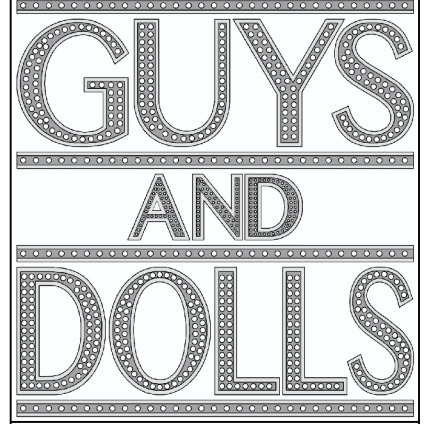

Venue

STEVENS CENTER

Producer

UNCSA

Director

GUS KAIKKONEN

Production Manager

DENNIS BOOTH

Scenic Designer

GARRET DAUB

Lighting Designer

AL CRAWFORD

Drawn By: GTS & TAC

File Name: Guys and Dolls v2015.dwg

Drawing Date: 04/25/15

Load-In Date

20 MARCH, 2015

Load-Out Date

19 APRIL, 2015

TIME SHEET - GRAHAM

Plate
12.1

Graham Schwartz Time Sheet

Date			8:00am	9:00am	10:00am	11:00am	12:00pm	1:00pm	2:00pm	3:00pm	4:00pm	5:00pm	6:00pm	7:00pm	8:00pm	9:00pm	10:00pm	11:00pm	12:00am	Total	
Sunday	March 15	Estimated																		Estimated	0
		Actual																			Actual
Monday	March 16	Estimated																		Estimated	8
		Actual																		Actual	8
Tuesday	March 17	Estimated																		Estimated	4
		Actual																		Actual	4
Wednesday	March 18	Estimated																		Estimated	4
		Actual																		Actual	4
Thursday	March 19	Estimated																		Estimated	4
		Actual																		Actual	4
Friday	March 20	Estimated																		Estimated	8
		Actual																		Actual	8
Saturday	March 21	Estimated																		Estimated	8
		Actual																		Actual	8
		Estimated Total																		36	
		Actual Total																		36	

Date			8:00am	9:00am	10:00am	11:00am	12:00pm	1:00pm	2:00pm	3:00pm	4:00pm	5:00pm	6:00pm	7:00pm	8:00pm	9:00pm	10:00pm	11:00pm	12:00am	Total	
Sunday	March 22	Estimated																		Estimated	8
		Actual																		Actual	12
Monday	March 23	Estimated																		Estimated	8
		Actual																		Actual	8
Tuesday	March 24	Estimated																		Estimated	4
		Actual																		Actual	4
Wednesday	March 25	Estimated																		Estimated	8
		Actual																		Actual	8
Thursday	March 26	Estimated																		Estimated	4
		Actual																		Actual	4
Friday	March 27	Estimated																		Estimated	8
		Actual																		Actual	8
Saturday	March 28	Estimated																		Estimated	9
		Actual																		Actual	9
		Estimated Total																		49	
		Actual Total																		53	

Tracy Cowit

Head Sound A1

Sound Designer
Drew Levy

Associate Sound Designer

Maria Wurttele

305.878.0893

wurttele.mf@artist.uncsa.edu

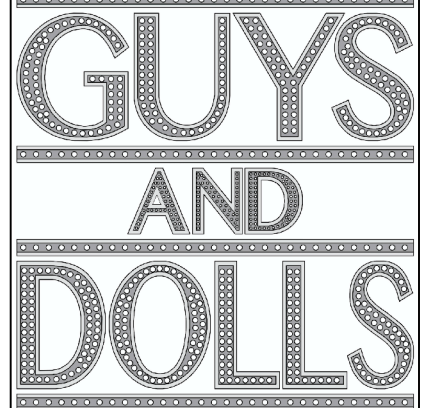

Venue

STEVENS CENTER

Producer

UNCSA

Director

GUS KAIKKONEN

Production Manager

DENNIS BOOTH

Scenic Designer

GARRET DAUB

Lighting Designer

AL CRAWFORD

Drawn By: GTS & TAC

File Name: Guys and Dolls v2015.dwg

Drawing Date: 04/25/15

Load-In Date

20 MARCH, 2015

Load-Out Date

19 APRIL, 2015

TIME SHEET - GRAHAM

Plate
12.2

Graham Schwartz Time Sheet

Date			8:00am	9:00am	10:00am	11:00am	12:00pm	1:00pm	2:00pm	3:00pm	4:00pm	5:00pm	6:00pm	7:00pm	8:00pm	9:00pm	10:00pm	11:00pm	12:00am	Total	
Sunday	March 29	Estimated																		Estimated	0
		Actual																		Actual	0
Monday	March 30	Estimated																		Estimated	8.5
		Actual																		Actual	9
Tuesday	March 31	Estimated																		Estimated	0
		Actual																		Actual	0
Wednesday	April 01	Estimated																		Estimated	8
		Actual																		Actual	9
Thursday	April 02	Estimated																		Estimated	4
		Actual																		Actual	5
Friday	April 03	Estimated																		Estimated	8.5
		Actual																		Actual	12
Saturday	April 04	Estimated																		Estimated	14
		Actual																		Actual	14
																				Estimated Total	43
																				Actual Total	49

Date			8:00am	9:00am	10:00am	11:00am	12:00pm	1:00pm	2:00pm	3:00pm	4:00pm	5:00pm	6:00pm	7:00pm	8:00pm	9:00pm	10:00pm	11:00pm	12:00am	Total	
Sunday	April 05	Estimated																		Estimated	0
		Actual																		Actual	0
Monday	April 06	Estimated																		Estimated	8
		Actual																		Actual	8.5
Tuesday	April 07	Estimated																		Estimated	6
		Actual																		Actual	6.5
Wednesday	April 08	Estimated																		Estimated	4
		Actual																		Actual	4.5
Thursday	April 09	Estimated																		Estimated	0
		Actual																		Actual	0
Friday	April 10	Estimated																		Estimated	0
		Actual																		Actual	0
Saturday	April 11	Estimated																		Estimated	0
		Actual																		Actual	0
																				Estimated Total	18
																				Actual Total	20

Tracy Cowit

Head Sound A1

Sound Designer
Drew Levy

Associate Sound Designer

Maria Wurttele

305.878.0893

wurttele.mf@artist.uncsa.edu

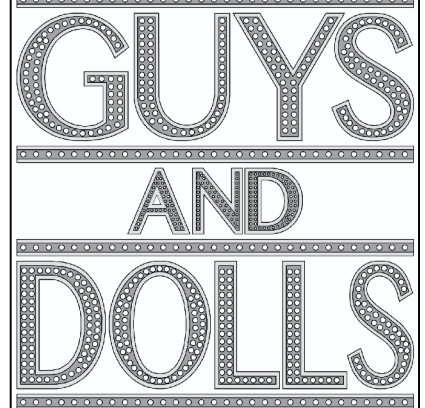

Venue

STEVENS CENTER

Producer

UNCSA

Director

GUS KAIKKONEN

Production Manager

DENNIS BOOTH

Scenic Designer

GARRET DAUB

Lighting Designer

AL CRAWFORD

Drawn By: GTS & TAC
File Name: Guys and Dolls v2015.dwg
Drawing Date: 04/25/15

Load-In Date: 20 MARCH, 2015
Load-Out Date: 19 APRIL, 2015

TIME SHEET - GRAHAM

Plate
12.3

Graham Schwartz Time Sheet

Tracy Cowit

Head Sound A1

Sound Designer
Drew Levy

Associate Sound Designer
Maria Wurttele

305.878.0893

wurttele.mf@artist.uncsa.edu

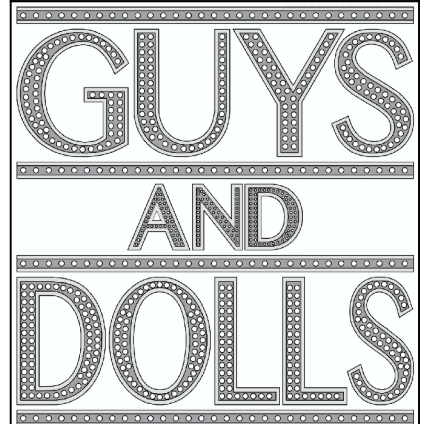

Venue

STEVENS CENTER

Producer

UNCSA

Director

GUS KAIKKONEN

Production Manager

DENNIS BOOTH

Scenic Designer

GARRET DAUB

Lighting Designer

AL CRAWFORD

Drawn By: GTS & TAC
File Name: Guys and Dolls v2015.dwg
Drawing Date: 04/25/15

Load-In Date: 20 MARCH, 2015 Load-Out Date: 19 APRIL, 2015

TIME SHEET - GRAHAM

Plate
12.4

Date			8:00am	9:00am	10:00am	11:00am	12:00pm	1:00pm	2:00pm	3:00pm	4:00pm	5:00pm	6:00pm	7:00pm	8:00pm	9:00pm	10:00pm	11:00pm	12:00am	Total		
Sunday	April 12	Estimated																			Estimated	0
		Actual																				Actual
Monday	April 13	Estimated																			Estimated	0
		Actual																				Actual
Tuesday	April 14	Estimated																			Estimated	0
		Actual																				Actual
Wednesday	April 15	Estimated																			Estimated	0
		Actual																				Actual
Thursday	April 16	Estimated																			Estimated	0
		Actual																				Actual
Friday	April 17	Estimated																			Estimated	0
		Actual																				Actual
Saturday	April 18	Estimated																			Estimated	11
		Actual																				Actual
		Estimated Total																		Estimated Total	11	
		Actual Total																		Actual Total	11	

Date			8:00am	9:00am	10:00am	11:00am	12:00pm	1:00pm	2:00pm	3:00pm	4:00pm	5:00pm	6:00pm	7:00pm	8:00pm	9:00pm	10:00pm	11:00pm	12:00am	Total		
Sunday	April 19	Estimated																			Estimated	4
		Actual																				Actual
Monday	April 20	Estimated																			Estimated	8
		Actual																				Actual
Tuesday	April 21	Estimated																			Estimated	4
		Actual																				Actual
Wednesday	April 22	Estimated																			Estimated	0
		Actual																				Actual
Thursday	April 23	Estimated																			Estimated	0
		Actual																				Actual
Friday	April 24	Estimated																			Estimated	0
		Actual																				Actual
Saturday	April 25	Estimated																			Estimated	0
		Actual																				Actual
		Estimated Total																		Estimated Total	16	
		Actual Total																		Actual Total	17	

Rosio Medina Time Sheet

Date			8:00am	9:00am	10:00am	11:00am	12:00pm	1:00pm	2:00pm	3:00pm	4:00pm	5:00pm	6:00pm	7:00pm	8:00pm	9:00pm	10:00pm	11:00pm	12:00am	Total		
Sunday	March 01	Estimated																			Estimated	0
		Actual																			Actual	0
Monday	March 02	Estimated																			Estimated	4
		Actual																			Actual	4
Tuesday	March 03	Estimated																			Estimated	4
		Actual																			Actual	4
Wednesday	March 04	Estimated																			Estimated	8
		Actual																			Actual	8
Thursday	March 05	Estimated																			Estimated	0
		Actual																			Actual	4
Friday	March 06	Estimated																			Estimated	4
		Actual																			Actual	4
Saturday	March 07	Estimated																			Estimated	0
		Actual																			Actual	0
																				Estimated Total	20	
																				Actual Total	24	

Date			8:00am	9:00am	10:00am	11:00am	12:00pm	1:00pm	2:00pm	3:00pm	4:00pm	5:00pm	6:00pm	7:00pm	8:00pm	9:00pm	10:00pm	11:00pm	12:00am	Total		
Sunday	March 08	Estimated																			Estimated	0
		Actual																			Actual	0
Monday	March 09	Estimated																			Estimated	0
		Actual																			Actual	0
Tuesday	March 10	Estimated																			Estimated	0
		Actual																			Actual	0
Wednesday	March 11	Estimated																			Estimated	0
		Actual																			Actual	0
Thursday	March 12	Estimated																			Estimated	0
		Actual																			Actual	0
Friday	March 13	Estimated																			Estimated	0
		Actual																			Actual	0
Saturday	March 14	Estimated																			Estimated	0
		Actual																			Actual	0
																				Estimated Total	0	
																				Actual Total	0	

Tracy Cowit

Head Sound A1

Sound Designer
Drew Levy

Associate Sound Designer
Maria Wurttele

305.878.0893

wurttele.mf@artist.uncsa.edu

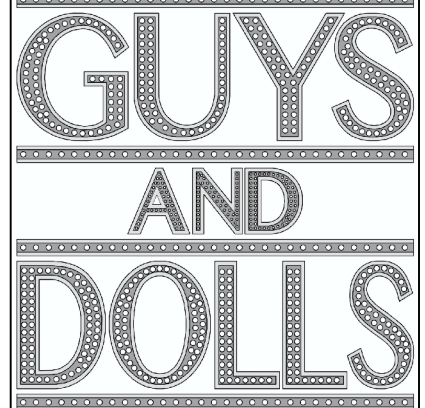

Venue

STEVENS CENTER

Producer

UNCSA

Director

GUS KAIKKONEN

Production Manager

DENNIS BOOTH

Scenic Designer

GARRET DAUB

Lighting Designer

AL CRAWFORD

Drawn By: GTS & TAC

File Name: Guys and Dolls v2015.dwg

Drawing Date: 04/25/15

Load-In Date

20 MARCH, 2015

Load-Out Date

19 APRIL, 2015

TIME SHEET - ROSIO

Plate
13.1

Rosio Medina Time Sheet

Date			8:00am	9:00am	10:00am	11:00am	12:00pm	1:00pm	2:00pm	3:00pm	4:00pm	5:00pm	6:00pm	7:00pm	8:00pm	9:00pm	10:00pm	11:00pm	12:00am	Total	
Sunday	March 15	Estimated																		Estimated	0
		Actual																			Actual
Monday	March 16	Estimated																		Estimated	8
		Actual																		Actual	8
Tuesday	March 17	Estimated																		Estimated	4
		Actual																		Actual	4
Wednesday	March 18	Estimated																		Estimated	8
		Actual																		Actual	8
Thursday	March 19	Estimated																		Estimated	4
		Actual																		Actual	4
Friday	March 20	Estimated																		Estimated	10
		Actual																		Actual	10
Saturday	March 21	Estimated																		Estimated	8
		Actual																		Actual	8
																				Estimated Total	42
																				Actual Total	42

Date			8:00am	9:00am	10:00am	11:00am	12:00pm	1:00pm	2:00pm	3:00pm	4:00pm	5:00pm	6:00pm	7:00pm	8:00pm	9:00pm	10:00pm	11:00pm	12:00am	Total	
Sunday	March 22	Estimated																		Estimated	8
		Actual																		Actual	12
Monday	March 23	Estimated																		Estimated	8
		Actual																		Actual	8
Tuesday	March 24	Estimated																		Estimated	4
		Actual																		Actual	4
Wednesday	March 25	Estimated																		Estimated	8
		Actual																		Actual	8
Thursday	March 26	Estimated																		Estimated	4
		Actual																		Actual	4
Friday	March 27	Estimated																		Estimated	12
		Actual																		Actual	12
Saturday	March 28	Estimated																		Estimated	9
		Actual																		Actual	9
																				Estimated Total	53
																				Actual Total	57

Tracy Cowit

Head Sound A1

Sound Designer

Drew Levy

Associate Sound Designer

Maria Wurttele

305.878.0893

wurttele.mf@artist.uncsa.edu

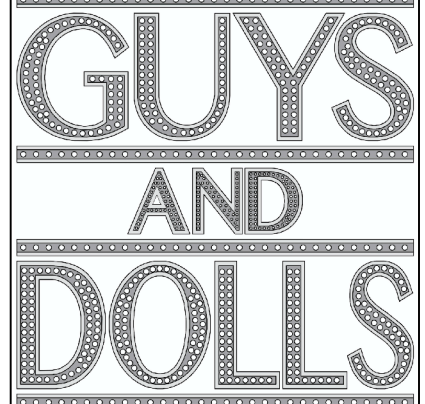

Venue

STEVENS CENTER

Producer

UNCSA

Director

GUS KAIKKONEN

Production Manager

DENNIS BOOTH

Scenic Designer

GARRET DAUB

Lighting Designer

AL CRAWFORD

Drawn By: GTS & TAC

File Name: Guys and Dolls v2015.dwg

Drawing Date: 04/25/15

Load-In Date

20 MARCH, 2015

Load-Out Date

19 APRIL, 2015

TIME SHEET - ROSIO

Plate
13.2

Rosio Medina Time Sheet

Date			8:00am	9:00am	10:00am	11:00am	12:00pm	1:00pm	2:00pm	3:00pm	4:00pm	5:00pm	6:00pm	7:00pm	8:00pm	9:00pm	10:00pm	11:00pm	12:00am	Total	
Sunday	March 29	Estimated																		Estimated	0
		Actual																		Actual	0
Monday	March 30	Estimated																		Estimated	8.5
		Actual																		Actual	9
Tuesday	March 31	Estimated																		Estimated	6
		Actual																		Actual	6.5
Wednesday	April 01	Estimated																		Estimated	8
		Actual																		Actual	9
Thursday	April 02	Estimated																		Estimated	5
		Actual																		Actual	6
Friday	April 03	Estimated																		Estimated	8.5
		Actual																		Actual	12
Saturday	April 04	Estimated																		Estimated	14
		Actual																		Actual	14
																				Estimated Total	50
																				Actual Total	56

Date			8:00am	9:00am	10:00am	11:00am	12:00pm	1:00pm	2:00pm	3:00pm	4:00pm	5:00pm	6:00pm	7:00pm	8:00pm	9:00pm	10:00pm	11:00pm	12:00am	Total	
Sunday	April 05	Estimated																		Estimated	0
		Actual																		Actual	0
Monday	April 06	Estimated																		Estimated	8
		Actual																		Actual	9.5
Tuesday	April 07	Estimated																		Estimated	6
		Actual																		Actual	6.5
Wednesday	April 08	Estimated																		Estimated	8
		Actual																		Actual	9
Thursday	April 09	Estimated																		Estimated	5.5
		Actual																		Actual	5.5
Friday	April 10	Estimated																		Estimated	5.5
		Actual																		Actual	5.5
Saturday	April 11	Estimated																		Estimated	5
		Actual																		Actual	5.5
																				Estimated Total	38
																				Actual Total	42

Tracy Cowit

Head Sound A1

Sound Designer
Drew Levy

Associate Sound Designer
Maria Wurttele

305.878.0893

wurttele.mf@artist.uncsa.edu

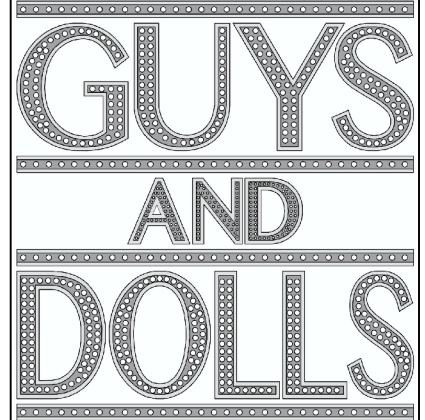

Venue

STEVENS CENTER

Producer

UNCSA

Director

GUS KAIKKONEN

Production Manager

DENNIS BOOTH

Scenic Designer

GARRET DAUB

Lighting Designer

AL CRAWFORD

Drawn By: GTS & TAC

File Name: Guys and Dolls v2015.dwg

Drawing Date: 04/25/15

Load-In Date

20 MARCH, 2015

Load-Out Date

19 APRIL, 2015

TIME SHEET - ROSIO

Plate
13.3

Rosio Medina Time Sheet

Date			8:00am	9:00am	10:00am	11:00am	12:00pm	1:00pm	2:00pm	3:00pm	4:00pm	5:00pm	6:00pm	7:00pm	8:00pm	9:00pm	10:00pm	11:00pm	12:00am	Total		
Sunday	April 12	Estimated																			Estimated	5
		Actual																				Actual
Monday	April 13	Estimated																			Estimated	0
		Actual																				Actual
Tuesday	April 14	Estimated																			Estimated	0
		Actual																				Actual
Wednesday	April 15	Estimated																			Estimated	6
		Actual																				Actual
Thursday	April 16	Estimated																			Estimated	6
		Actual																				Actual
Friday	April 17	Estimated																			Estimated	6
		Actual																				Actual
Saturday	April 18	Estimated																			Estimated	11
		Actual																				Actual
																				Estimated Total	34	
																				Actual Total	34	

Date			8:00am	9:00am	10:00am	11:00am	12:00pm	1:00pm	2:00pm	3:00pm	4:00pm	5:00pm	6:00pm	7:00pm	8:00pm	9:00pm	10:00pm	11:00pm	12:00am	Total		
Sunday	April 19	Estimated																			Estimated	9
		Actual																				Actual
Monday	April 20	Estimated																			Estimated	8
		Actual																				Actual
Tuesday	April 21	Estimated																			Estimated	4
		Actual																				Actual
Wednesday	April 22	Estimated																			Estimated	0
		Actual																				Actual
Thursday	April 23	Estimated																			Estimated	0
		Actual																				Actual
Friday	April 24	Estimated																			Estimated	0
		Actual																				Actual
Saturday	April 25	Estimated																			Estimated	0
		Actual																				Actual
																				Estimated Total	21	
																				Actual Total	22	

Tracy Cowit

Head Sound A1

Sound Designer
Drew Levy

Associate Sound Designer

Maria Wurttele

305.878.0893

wurttele.mf@artist.uncsa.edu

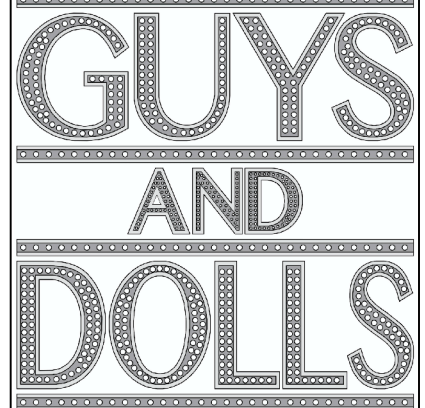

Venue

STEVENS CENTER

Producer

UNCSA

Director

GUS KAIKKONEN

Production Manager

DENNIS BOOTH

Scenic Designer

GARRET DAUB

Lighting Designer

AL CRAWFORD

Drawn By: GTS & TAC

File Name: Guys and Dolls v2015.dwg

Drawing Date: 04/25/15

Load-In Date

20 MARCH, 2015

Load-Out Date

19 APRIL, 2015

TIME SHEET - ROSIO

Plate
13.4

Andrew Jerry Time Sheet

Date			8:00am	9:00am	10:00am	11:00am	12:00pm	1:00pm	2:00pm	3:00pm	4:00pm	5:00pm	6:00pm	7:00pm	8:00pm	9:00pm	10:00pm	11:00pm	12:00am	Total		
Sunday	March 01	Estimated																			Estimated	0
		Actual																			Actual	0
Monday	March 02	Estimated																			Estimated	4
		Actual																			Actual	4
Tuesday	March 03	Estimated																			Estimated	4
		Actual																			Actual	4
Wednesday	March 04	Estimated																			Estimated	8
		Actual																			Actual	8
Thursday	March 05	Estimated																			Estimated	0
		Actual																			Actual	0
Friday	March 06	Estimated																			Estimated	4
		Actual																			Actual	4
Saturday	March 07	Estimated																			Estimated	0
		Actual																			Actual	0
																				Estimated Total	20	
																				Actual Total	20	

Date			8:00am	9:00am	10:00am	11:00am	12:00pm	1:00pm	2:00pm	3:00pm	4:00pm	5:00pm	6:00pm	7:00pm	8:00pm	9:00pm	10:00pm	11:00pm	12:00am	Total		
Sunday	March 08	Estimated																			Estimated	0
		Actual																			Actual	0
Monday	March 09	Estimated																			Estimated	0
		Actual																			Actual	0
Tuesday	March 10	Estimated																			Estimated	0
		Actual																			Actual	0
Wednesday	March 11	Estimated																			Estimated	0
		Actual																			Actual	0
Thursday	March 12	Estimated																			Estimated	0
		Actual																			Actual	0
Friday	March 13	Estimated																			Estimated	0
		Actual																			Actual	0
Saturday	March 14	Estimated																			Estimated	0
		Actual																			Actual	0
																				Estimated Total	0	
																				Actual Total	0	

Tracy Cowit

Head Sound A1

Sound Designer

Drew Levy

Associate Sound Designer

Maria Wurttele

305.878.0893

wurttele.mf@artist.uncsa.edu

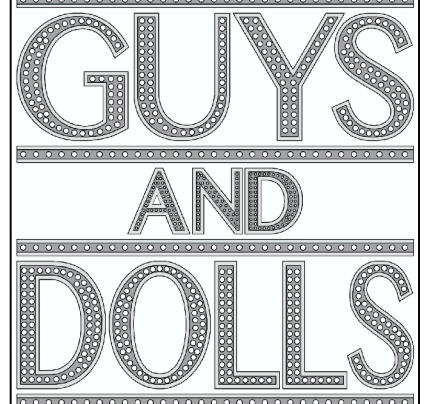

Venue

STEVENS CENTER

Producer

UNCSA

Director

GUS KAIKKONEN

Production Manager

DENNIS BOOTH

Scenic Designer

GARRET DAUB

Lighting Designer

AL CRAWFORD

Drawn By: GTS & TAC

File Name: Guys and Dolls v2015.dwg

Drawing Date: 04/25/15

Load-In Date

20 MARCH, 2015

Load-Out Date

19 APRIL, 2015

**TIME SHEET -
ANDREW JERRY**

Plate
14.1

Andrew Jerry Time Sheet

Date		8:00am	9:00am	10:00am	11:00am	12:00pm	1:00pm	2:00pm	3:00pm	4:00pm	5:00pm	6:00pm	7:00pm	8:00pm	9:00pm	10:00pm	11:00pm	12:00am	Total		
Sunday	March 15	Estimated																		Estimated	0
		Actual																		Actual	0
Monday	March 16	Estimated																		Estimated	8
		Actual																		Actual	8
Tuesday	March 17	Estimated																		Estimated	0
		Actual																		Actual	0
Wednesday	March 18	Estimated																		Estimated	4
		Actual																		Actual	4
Thursday	March 19	Estimated																		Estimated	4
		Actual																		Actual	4
Friday	March 20	Estimated																		Estimated	8
		Actual																		Actual	8
Saturday	March 21	Estimated																		Estimated	8
		Actual																		Actual	8
																			Estimated Total	32	
																			Actual Total	32	

Date		8:00am	9:00am	10:00am	11:00am	12:00pm	1:00pm	2:00pm	3:00pm	4:00pm	5:00pm	6:00pm	7:00pm	8:00pm	9:00pm	10:00pm	11:00pm	12:00am	Total		
Sunday	March 22	Estimated																		Estimated	8
		Actual																		Actual	8
Monday	March 23	Estimated																		Estimated	8
		Actual																		Actual	8
Tuesday	March 24	Estimated																		Estimated	0
		Actual																		Actual	0
Wednesday	March 25	Estimated																		Estimated	8
		Actual																		Actual	8
Thursday	March 26	Estimated																		Estimated	0
		Actual																		Actual	0
Friday	March 27	Estimated																		Estimated	8
		Actual																		Actual	8
Saturday	March 28	Estimated																		Estimated	9
		Actual																		Actual	9
																			Estimated Total	41	
																			Actual Total	41	

Tracy Cowit
Head Sound A1

Sound Designer
Drew Levy

Associate Sound Designer
Maria Wurttele
305.878.0893
wurttele.mf@artist.uncsa.edu

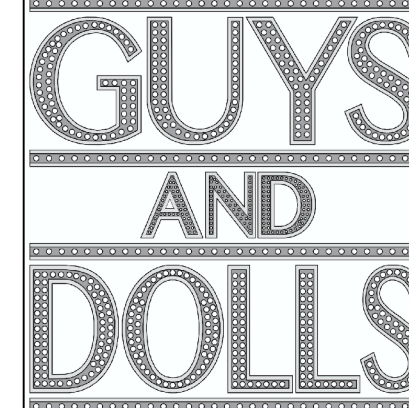

Venue
STEVENS CENTER

Producer
UNCSA

Director
GUS KAIKKONEN

Production Manager
DENNIS BOOTH

Scenic Designer
GARRET DAUB

Lighting Designer
AL CRAWFORD

Drawn By: GTS & TAC
File Name: Guys and Dolls v2015.dwg
Drawing Date: 04/25/15

Load-In Date: 20 MARCH, 2015
Load-Out Date: 19 APRIL, 2015

**TIME SHEET -
ANDREW JERRY**

Plate
14.2

Andrew Jerry Time Sheet

Tracy Cowit

Head Sound A1

Sound Designer
Drew Levy

Associate Sound Designer
Maria Wurttele

305.878.0893

wurttele.mf@artist.uncsa.edu

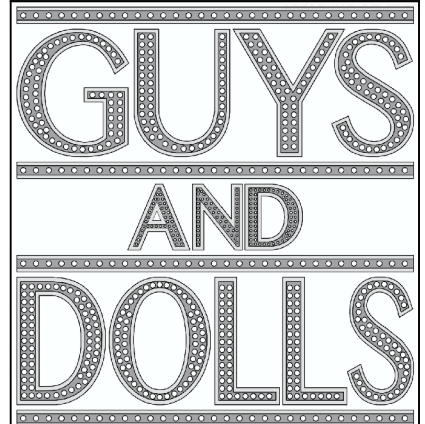

Venue

STEVENS CENTER

Producer

UNCSA

Director

GUS KAIKKONEN

Production Manager

DENNIS BOOTH

Scenic Designer

GARRET DAUB

Lighting Designer

AL CRAWFORD

Drawn By: GTS & TAC

File Name: Guys and Dolls v2015.dwg

Drawing Date: 04/25/15

Load-In Date

20 MARCH, 2015

Load-Out Date

19 APRIL, 2015

**TIME SHEET -
ANDREW JERRY**

Plate
14.3

Date			8:00am	9:00am	10:00am	11:00am	12:00pm	1:00pm	2:00pm	3:00pm	4:00pm	5:00pm	6:00pm	7:00pm	8:00pm	9:00pm	10:00pm	11:00pm	12:00am	Total		
Sunday	March 29	Estimated																			Estimated	0
		Actual																				Actual
Monday	March 30	Estimated																			Estimated	8.5
		Actual																				Actual
Tuesday	March 31	Estimated																			Estimated	0
		Actual																				Actual
Wednesday	April 01	Estimated																			Estimated	8
		Actual																				Actual
Thursday	April 02	Estimated																			Estimated	4
		Actual																				Actual
Friday	April 03	Estimated																			Estimated	8.5
		Actual																				Actual
Saturday	April 04	Estimated																			Estimated	14
		Actual																				Actual
																				Estimated Total	43	
																				Actual Total	44	

Date			8:00am	9:00am	10:00am	11:00am	12:00pm	1:00pm	2:00pm	3:00pm	4:00pm	5:00pm	6:00pm	7:00pm	8:00pm	9:00pm	10:00pm	11:00pm	12:00am	Total		
Sunday	April 05	Estimated																			Estimated	0
		Actual																				Actual
Monday	April 06	Estimated																			Estimated	8
		Actual																				Actual
Tuesday	April 07	Estimated																			Estimated	6
		Actual																				Actual
Wednesday	April 08	Estimated																			Estimated	8
		Actual																				Actual
Thursday	April 09	Estimated																			Estimated	5.5
		Actual																				Actual
Friday	April 10	Estimated																			Estimated	5.5
		Actual																				Actual
Saturday	April 11	Estimated																			Estimated	5
		Actual																				Actual
																				Estimated Total	38	
																				Actual Total	40	

Andrew Jerry Time Sheet

Tracy Cowit
Head Sound A1

Sound Designer
Drew Levy

Associate Sound Designer
Maria Wurttele
305.878.0893
wurttele.mf@artist.uncsa.edu

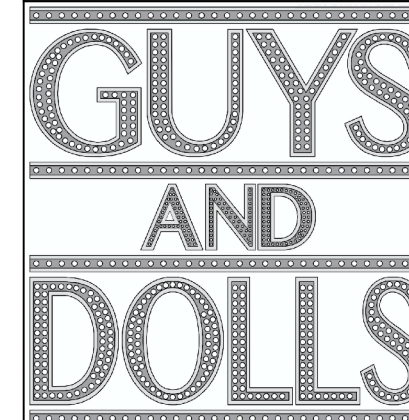

Venue
STEVENS CENTER

Producer
UNCSA

Director
GUS KAIKKONEN

Production Manager
DENNIS BOOTH

Scenic Designer
GARRET DAUB

Lighting Designer
AL CRAWFORD

Drawn By: GTS & TAC
File Name: Guys and Dolls v2015.dwg
Drawing Date: 04/25/15

Load-In Date: 20 MARCH, 2015
Load-Out Date: 19 APRIL, 2015

**TIME SHEET -
ANDREW JERRY**

Plate
14.4

Date			8:00am	9:00am	10:00am	11:00am	12:00pm	1:00pm	2:00pm	3:00pm	4:00pm	5:00pm	6:00pm	7:00pm	8:00pm	9:00pm	10:00pm	11:00pm	12:00am	Total	
Sunday	April 12	Estimated																		Estimated	5
		Actual																			Actual
Monday	April 13	Estimated																		Estimated	0
		Actual																			Actual
Tuesday	April 14	Estimated																		Estimated	0
		Actual																			Actual
Wednesday	April 15	Estimated																		Estimated	6
		Actual																			Actual
Thursday	April 16	Estimated																		Estimated	6
		Actual																			Actual
Friday	April 17	Estimated																		Estimated	6
		Actual																			Actual
Saturday	April 18	Estimated																		Estimated	11
		Actual																			Actual
																				Estimated Total	34
																				Actual Total	34

Date			8:00am	9:00am	10:00am	11:00am	12:00pm	1:00pm	2:00pm	3:00pm	4:00pm	5:00pm	6:00pm	7:00pm	8:00pm	9:00pm	10:00pm	11:00pm	12:00am	Total	
Sunday	April 19	Estimated																		Estimated	9
		Actual																			Actual
Monday	April 20	Estimated																		Estimated	8
		Actual																			Actual
Tuesday	April 21	Estimated																		Estimated	4
		Actual																			Actual
Wednesday	April 22	Estimated																		Estimated	0
		Actual																			Actual
Thursday	April 23	Estimated																		Estimated	0
		Actual																			Actual
Friday	April 24	Estimated																		Estimated	0
		Actual																			Actual
Saturday	April 25	Estimated																		Estimated	0
		Actual																			Actual
																				Estimated Total	21
																				Actual Total	20

Jason O'Neal Time Sheet

Date			8:00am	9:00am	10:00am	11:00am	12:00pm	1:00pm	2:00pm	3:00pm	4:00pm	5:00pm	6:00pm	7:00pm	8:00pm	9:00pm	10:00pm	11:00pm	12:00am	Total		
Sunday	March 01	Estimated																			Estimated	0
		Actual																			Actual	0
Monday	March 02	Estimated																			Estimated	4
		Actual																			Actual	4
Tuesday	March 03	Estimated																			Estimated	4
		Actual																			Actual	4
Wednesday	March 04	Estimated																			Estimated	8
		Actual																			Actual	8
Thursday	March 05	Estimated																			Estimated	0
		Actual																			Actual	0
Friday	March 06	Estimated																			Estimated	4
		Actual																			Actual	4
Saturday	March 07	Estimated																			Estimated	0
		Actual																			Actual	0
																				Estimated Total	20	
																				Actual Total	20	

Date			8:00am	9:00am	10:00am	11:00am	12:00pm	1:00pm	2:00pm	3:00pm	4:00pm	5:00pm	6:00pm	7:00pm	8:00pm	9:00pm	10:00pm	11:00pm	12:00am	Total		
Sunday	March 08	Estimated																			Estimated	0
		Actual																			Actual	0
Monday	March 09	Estimated																			Estimated	0
		Actual																			Actual	0
Tuesday	March 10	Estimated																			Estimated	0
		Actual																			Actual	0
Wednesday	March 11	Estimated																			Estimated	0
		Actual																			Actual	0
Thursday	March 12	Estimated																			Estimated	0
		Actual																			Actual	0
Friday	March 13	Estimated																			Estimated	0
		Actual																			Actual	0
Saturday	March 14	Estimated																			Estimated	0
		Actual																			Actual	0
																				Estimated Total	0	
																				Actual Total	0	

Tracy Cowit

Head Sound A1

Sound Designer

Drew Levy

Associate Sound Designer

Maria Wurttele

305.878.0893

wurttele.mf@artist.uncsa.edu

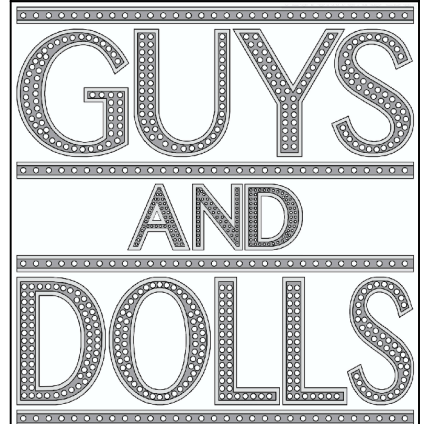

Venue

STEVENS CENTER

Producer

UNCSA

Director

GUS KAIKKONEN

Production Manager

DENNIS BOOTH

Scenic Designer

GARRET DAUB

Lighting Designer

AL CRAWFORD

Drawn By: GTS & TAC

File Name: Guys and Dolls v2015.dwg

Drawing Date: 04/25/15

Load-In Date

20 MARCH, 2015

Load-Out Date

19 APRIL, 2015

**TIME SHEET -
JASON O'NEAL**

Plate
15.1

Jason O'Neal Time Sheet

Date		8:00am	9:00am	10:00am	11:00am	12:00pm	1:00pm	2:00pm	3:00pm	4:00pm	5:00pm	6:00pm	7:00pm	8:00pm	9:00pm	10:00pm	11:00pm	12:00am	Total		
Sunday	March 15	Estimated																		Estimated	0
		Actual																		Actual	0
Monday	March 16	Estimated																		Estimated	8
		Actual																		Actual	8
Tuesday	March 17	Estimated																		Estimated	0
		Actual																		Actual	0
Wednesday	March 18	Estimated																		Estimated	4
		Actual																		Actual	4
Thursday	March 19	Estimated																		Estimated	4
		Actual																		Actual	4
Friday	March 20	Estimated																		Estimated	8
		Actual																		Actual	8
Saturday	March 21	Estimated																		Estimated	8
		Actual																		Actual	8
																			Estimated Total	32	
																			Actual Total	32	

Date		8:00am	9:00am	10:00am	11:00am	12:00pm	1:00pm	2:00pm	3:00pm	4:00pm	5:00pm	6:00pm	7:00pm	8:00pm	9:00pm	10:00pm	11:00pm	12:00am	Total		
Sunday	March 22	Estimated																		Estimated	8
		Actual																		Actual	8
Monday	March 23	Estimated																		Estimated	8
		Actual																		Actual	8
Tuesday	March 24	Estimated																		Estimated	0
		Actual																		Actual	0
Wednesday	March 25	Estimated																		Estimated	8
		Actual																		Actual	8
Thursday	March 26	Estimated																		Estimated	0
		Actual																		Actual	0
Friday	March 27	Estimated																		Estimated	8
		Actual																		Actual	8
Saturday	March 28	Estimated																		Estimated	9
		Actual																		Actual	9
																			Estimated Total	41	
																			Actual Total	41	

Tracy Cowit

Head Sound A1

Sound Designer
Drew Levy

Associate Sound Designer

Maria Wurttele

305.878.0893

wurttele.mf@artist.uncsa.edu

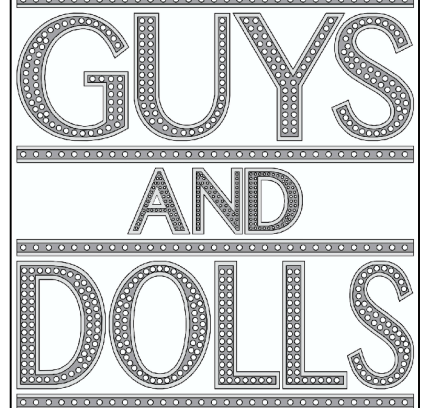

Venue

STEVENS CENTER

Producer

UNCSA

Director

GUS KAIKKONEN

Production Manager

DENNIS BOOTH

Scenic Designer

GARRET DAUB

Lighting Designer

AL CRAWFORD

Drawn By: GTS & TAC

File Name: Guys and Dolls v2015.dwg

Drawing Date: 04/25/15

Load-In Date

20 MARCH, 2015

Load-Out Date

19 APRIL, 2015

**TIME SHEET -
JASON O'NEAL**

Plate
15.2

Jason O'Neal Time Sheet

Date			8:00am	9:00am	10:00am	11:00am	12:00pm	1:00pm	2:00pm	3:00pm	4:00pm	5:00pm	6:00pm	7:00pm	8:00pm	9:00pm	10:00pm	11:00pm	12:00am	Total		
Sunday	March 29	Estimated																			Estimated	0
		Actual																				Actual
Monday	March 30	Estimated																			Estimated	8.5
		Actual																				Actual
Tuesday	March 31	Estimated																			Estimated	0
		Actual																				Actual
Wednesday	April 01	Estimated																			Estimated	8
		Actual																				Actual
Thursday	April 02	Estimated																			Estimated	5
		Actual																				Actual
Friday	April 03	Estimated																			Estimated	8.5
		Actual																				Actual
Saturday	April 04	Estimated																			Estimated	14
		Actual																				Actual
																				Estimated Total	44	
																				Actual Total	45	

Date			8:00am	9:00am	10:00am	11:00am	12:00pm	1:00pm	2:00pm	3:00pm	4:00pm	5:00pm	6:00pm	7:00pm	8:00pm	9:00pm	10:00pm	11:00pm	12:00am	Total		
Sunday	April 05	Estimated																			Estimated	0
		Actual																				Actual
Monday	April 06	Estimated																			Estimated	8
		Actual																				Actual
Tuesday	April 07	Estimated																			Estimated	6
		Actual																				Actual
Wednesday	April 08	Estimated																			Estimated	8
		Actual																				Actual
Thursday	April 09	Estimated																			Estimated	5.5
		Actual																				Actual
Friday	April 10	Estimated																			Estimated	5.5
		Actual																				Actual
Saturday	April 11	Estimated																			Estimated	5
		Actual																				Actual
																				Estimated Total	38	
																				Actual Total	38	

Tracy Cowit

Head Sound A1

Sound Designer

Drew Levy

Associate Sound Designer

Maria Wurttele

305.878.0893

wurttele.mf@artist.uncsa.edu

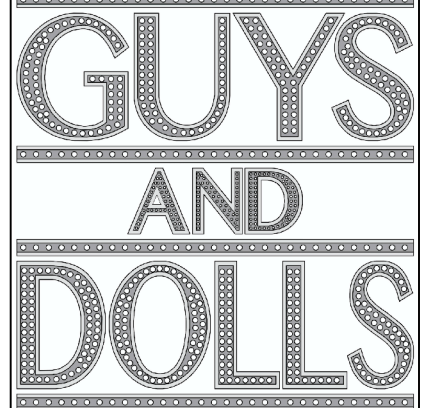

Venue

STEVENS CENTER

Producer

UNCSA

Director

GUS KAIKKONEN

Production Manager

DENNIS BOOTH

Scenic Designer

GARRET DAUB

Lighting Designer

AL CRAWFORD

Drawn By: GTS & TAC

File Name: Guys and Dolls v2015.dwg

Drawing Date: 04/25/15

Load-In Date

20 MARCH, 2015

Load-Out Date

19 APRIL, 2015

**TIME SHEET -
JASON O'NEAL**

Plate
15.3

Jason O'Neal Time Sheet

Tracy Cowit

Head Sound A1

Sound Designer

Drew Levy

Associate Sound Designer

Maria Wurttele

305.878.0893

wurttele.mf@artist.uncsa.edu

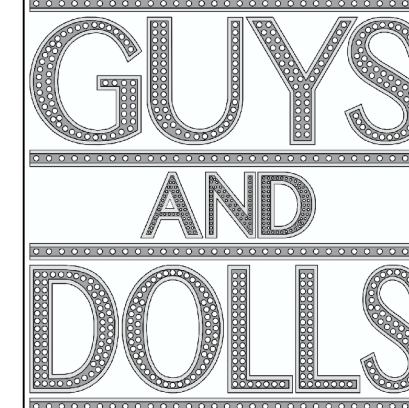

Venue

STEVENS CENTER

Producer

UNCSA

Director

GUS KAIKKONEN

Production Manager

DENNIS BOOTH

Scenic Designer

GARRET DAUB

Lighting Designer

AL CRAWFORD

Drawn By: GTS & TAC

File Name: Guys and Dolls v2015.dwg

Drawing Date: 04/25/15

Load-In Date

20 MARCH, 2015

Load-Out Date

19 APRIL, 2015

**TIME SHEET -
JASON O'NEAL**

Plate
15.4

Date			8:00am	9:00am	10:00am	11:00am	12:00pm	1:00pm	2:00pm	3:00pm	4:00pm	5:00pm	6:00pm	7:00pm	8:00pm	9:00pm	10:00pm	11:00pm	12:00am	Total		
Sunday	April 12	Estimated																			Estimated	5
		Actual																				Actual
Monday	April 13	Estimated																			Estimated	0
		Actual																				Actual
Tuesday	April 14	Estimated																			Estimated	0
		Actual																				Actual
Wednesday	April 15	Estimated																			Estimated	6
		Actual																				Actual
Thursday	April 16	Estimated																			Estimated	6
		Actual																				Actual
Friday	April 17	Estimated																			Estimated	6
		Actual																				Actual
Saturday	April 18	Estimated																			Estimated	0
		Actual																				Actual
		Estimated Total																		23		
		Actual Total																		23		

Date			8:00am	9:00am	10:00am	11:00am	12:00pm	1:00pm	2:00pm	3:00pm	4:00pm	5:00pm	6:00pm	7:00pm	8:00pm	9:00pm	10:00pm	11:00pm	12:00am	Total		
Sunday	April 19	Estimated																			Estimated	9
		Actual																				Actual
Monday	April 20	Estimated																			Estimated	8
		Actual																				Actual
Tuesday	April 21	Estimated																			Estimated	4
		Actual																				Actual
Wednesday	April 22	Estimated																			Estimated	0
		Actual																				Actual
Thursday	April 23	Estimated																			Estimated	0
		Actual																				Actual
Friday	April 24	Estimated																			Estimated	0
		Actual																				Actual
Saturday	April 25	Estimated																			Estimated	0
		Actual																				Actual
		Estimated Total																		21		
		Actual Total																		19		